

Fabrication and Characterization of Self-Aligned ZnO and TiO₂ Nanostructured Films

Bashir Ahmmad*, Shogo Hayasaka, Kensaku Kanomata, Shigeru Kubota and Fumihoko Hirose
Graduate School of Science and Engineering, Yamagata University
4-3-16 Jonan, Yonezawa 992-8510, Japan

*E-mail: arima@yz.yamagata-u.ac.jp

Abstract— Self-aligned nanostructured thin films of ZnO and TiO₂ have been prepared by MOCVD and anodization method, respectively. The as-prepared films were characterized by XRD, SEM and XPS analysis. The deposition temperature and time have drastic effects on the crystallinity and morphology of the nanostructured ZnO films. On the other hand, films of TiO₂ nanotube array (TNA) are markedly affected by the composition of electrolyte used during anodization process. The as-prepared TNA films are amorphous in nature but high crystalline anatase phase could be obtained at low temperature using hydrothermal treatment.

Keywords- ZnO films, Whisker, chemical vapor deposition, Titania nanotube array, anodization, hydrothermal treatment.

I. INTRODUCTION

In recent years, metal oxide nanoparticles have attracted substantial interest because of their unique optical, magnetic and electronic properties, which are different from their bulk and highly dependent on their sizes, shape, orientation, and crystallinities [1]. Among various transition metal oxide nanostructures, ZnO and TiO₂ are particularly important due to their positive qualities, such as low cost, good stability, nontoxicity and their applications in catalysis, sensors, adsorption, and electronic devices [2].

Although ZnO and TiO₂ possesses roughly similar value of energy band gap (approximately 3.2 eV), the two semiconductors found their own dominating fields of applications due to differences in their intrinsic semiconductor characteristics. The ZnO is preferred in optoelectronic devices as light emitter or transparent conductive electrode owing to semiconductor large exciton binding [3]. On the other hand, TiO₂ is better for application in catalysis and photocatalysis [4-6] as well as solar cells [7]. Moreover, TiO₂ films have a high refractive index and high dielectric constant; they are transparent in the visible and near-infrared range. Therefore, they can be used as a pigment and ultraviolet (UV) filter in the cosmetic industry, as an antireflective coating in the glass industry and as a dielectric material for integrated circuits [8].

The one-dimensional and porous nanostructured films of metal oxides with very large internal surface are offers a number of fascinating features that are advantageous in

designing of optoelectronic devices and sensors. Various one-dimensional ZnO nanomaterials including whiskers, nanowire, nanotubes, nanorods have been prepared by different methods. Among, metal-organic chemical vapor deposition (MOCVD) is simple and provides several parameters to control the growth and morphology of ZnO nanostructures. Recently, Liu et al., reported temperature controlled tower-shaped ZnO nanostructures and their optical properties grown on Si substrates by MOCVD method [12]. They changed the temperature from 300 to 475°C and found a multilayer-tower and rod shaped nanostructures. However, they did not control the deposition temperature carefully and at a small interval. Also, information on growth rate and the effect of deposition time on morphology of ZnO have not been described in their report. In this work we show that several new morphologies such as whisker-shaped and flower-like ZnO nanostructures could selectively be grown by careful control of deposition temperatures and time of the MOCVD method.

On the other hand, one dimensional tubular nanostructures of TiO₂ is considered to be the most promising architecture due to its low charge carrier recombination losses, easy transfer of photoelectrons and trapping of reflected light [10]. Highly ordered and self-organized titania nanotube arrays can be synthesized by electrochemical anodic oxidation or anodization of titanium foil. However, the as-prepared TiO₂ nanotubes are amorphous in nature and therefore, calcination at high temperature (about 500 °C) is required to obtain anatase phase, which is mainly used in photocatalysis and solar cells. In this report we show that anatase phase of TiO₂ nanotube could be obtained by hydrothermal treatment at low temperature (175 °C) which could be considered as an eco-friendly method. Both ZnO and TiO₂ nanostructured thin films are potential for electronic devices and solar cells.

II. METHOD

A. Fabrication of Nanostructured ZnO film

Films of nanostructured ZnO were prepared by metal organic chemical vapor deposition (MOCVD) method using bis-acetylacetonato zinc monohydrate, (Zn(C₅H₇O₂)₂·H₂O) (99%, Wako, Japan) as a precursor. The precursor was

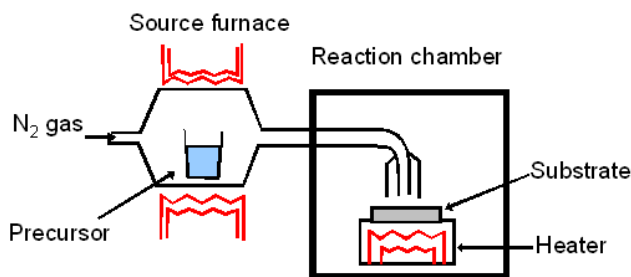

Scheme 1 . Schematic diagram of metal organic chemical vapor deposition (MOCVD) method.

vaporized in a chamber (scheme 1), which was set at a temperature of 115 °C. The vaporized precursor was brought into a nozzle by nitrogen as carrier gas (with flow rate of 1 ml/min) and deposited on the preheated Si (100) substrate for a certain period of time ranging from 5 to 120 min. During the deposition of precursors, oxidation and crystallization took place to form ZnO nanostructures. A series of growth were performed at the substrate temperature ranging from 200 to 550 °C at the interval of 50 °C.

B. Fabrication of TiO₂ nanotube array

Titanium foils (100 μm thick, 99%, Nilaco) were washed with acetone, soap, and iso-propanol before anodization. Each anodization was performed at room temperature using a two-electrode electrochemical cell, with 2.5 cm × 2.5 cm titanium foil as an anode and platinum foil as a cathode. The anodization-electrolytes were prepared in two different conditions by mixing diethylene glycol (DEG, 99%, Wako) with HF (48% solution, Wako) and EG (99.5%, Wako) with NH₄F (98%, Wako). The electrodes were connected to the DC power supply. After anodization, the films were rinsed with iso-propanol and blow dried. The as-prepared TNA films were calcined under nitrogen at different temperatures ranging from 350 °C to 650 °C or subjected to hydrothermal treatment. For hydrothermal treatment, the film was transferred to Teflon-line autoclave. The film was set on a handmade stand in the Teflon container, which was then filled with water upto a point just below the film (Scheme 2). Water covered 70% of the total volume of container. Finally, autoclave was heated at different temperatures ranging 100~175 °C for 5 h.

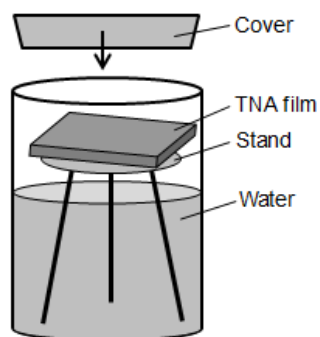

Scheme 2 . Schematic diagram of setup for hydrothermal treatment of TNA films.

C. Characterization of the films

Morphologies of nanostructured ZnO and TiO₂ films of were characterized by a scanning electron microscope (SEM, JEOL, JSM 5800). Crystal structures were analyzed by X-ray diffraction analysis (XRD, Rigaku ultimate VII). Chemical composition of nanostructured films were analyzed by X-ray photoluminescence spectroscopy (XPS, Hitachi).

III. RESULTS AND DISCUSSION

A. Nanostructured ZnO films

The XRD patterns of ZnO films prepared under different deposition temperature are shown in Fig. 1. A large peak was shown for Si(400) at $2\theta=70^\circ$ in all cases which comes from the substrate. At lower temperature (200~300 °C), (002) peak for ZnO shows high intensity (Fig. 1 a, b) indicating that the ZnO crystallinities are preferentially oriented with their c-axis being perpendicular to the Si substrate. At the deposition temperature of 400 °C, the intensity of (110) peak becomes higher than (002) peak. With increasing the deposition temperature (500 °C) different other peaks (such as 102, 103, 200) also appear indicating that the crystallinities are oriented in different directions.

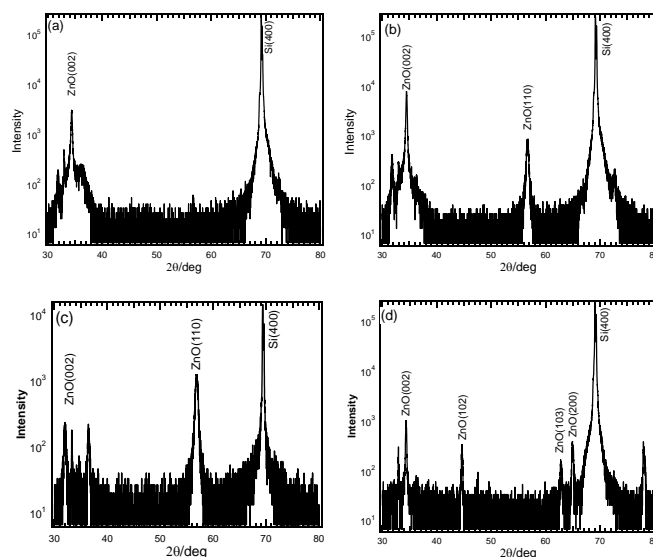

Figure 1. XRD patterns of ZnO films prepared at (a) 200 °C (b) 300 °C (c) 400 °C and (d) 500 °C.

The variation in the morphology of ZnO films with increasing deposition temperature is shown in Fig. 2. It is seen that morphology of nanostructured particles changes with changing substrate temperatures. At lower temperature (200~250 °C), any specific structure of ZnO was not observed and the substrate was covered homogeneously by granular ZnO particles. The grain sizes of ZnO at 200 °C range from 10~20 nm and at 250 °C, these grains are aggregated to form bigger particles of sizes 80~150 nm. At 300~350 °C, compact plate-like structures of ZnO are seen which are perpendicular to the substrate and have a low height. The approximate thickness and width (horizontal axis) of plate-like nanostructure were

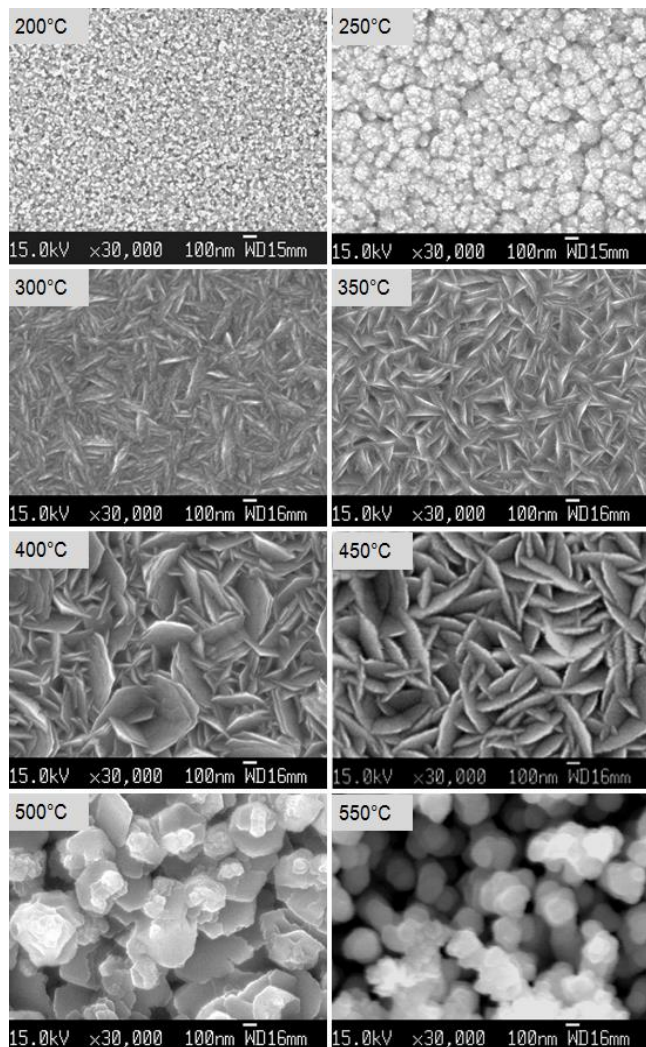

Figure 2. SEM images of ZnO films prepared at different deposition temperatures.

found to be 20 nm and 100~150 nm, respectively. Further elevation of temperature (400~450°C) results increased thickness, height and sizes of the plate-like whiskers. The thickness of ZnO films prepared at 450 °C is found to be 300 nm. However, at around 500 °C, the films lose their plate-like nanostructures and multilayer-tower (nearly flower-like) nanostructures were observed. At 550 °C or above, stack of granular particles form tower-like structures.

The temperature of the substrate was kept constant at 400 °C and the deposition time was changed from 5 to 120 min. Fig. 3 shows the SEM images of the films prepared after different deposition time. It is clear that minimum 10 minutes of growth time is necessary for the formation of whisker shaped nanostructures. With increasing the growth time up to 60 minutes the height of nanoplates increases without changing their shapes. The size and thickness of the nanoplates do not differ from those prepared by controlling the deposition temperature in Fig. 2 (400~450 °C). However, above 60 minutes of growth time, the plate-like whiskers partly disappear and small plate-like structures centered at some points appear, which together with bigger plate-like structures

form a flower-like nanostructures (Fig. 4(f)). The diameter of unit flower-like structure ranges from 1~2 μm . These results indicate that growth time in MOCVD method has a strong influence on the morphology of the nanostructure films.

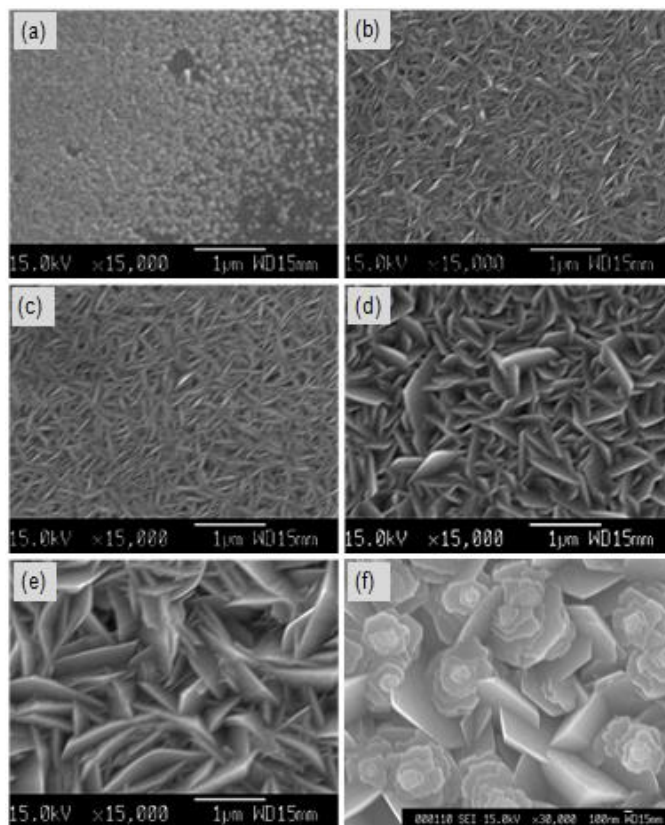

Figure 3. SEM images of ZnO films prepared at different deposition times; (a) 5 min, (b) 10 min, (c) 15 min, (d) 30 min, (e) 60 min, and (f) 120 min.

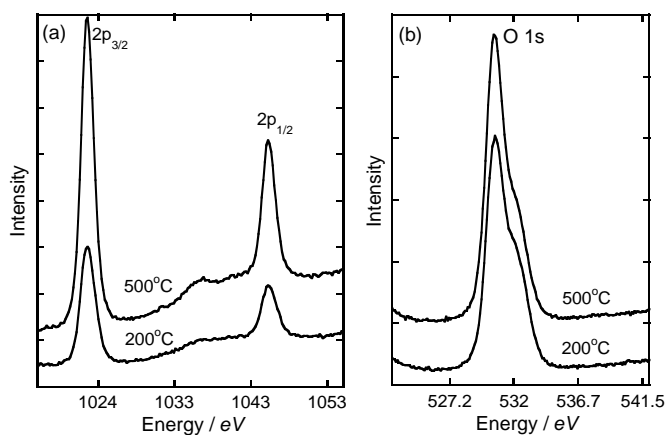

Figure 4. XPS spectra of ZnO films; (a) Zn-2p region, and (b) O-1s region.

The XPS spectra of ZnO films prepared at 200 °C and 500 °C are shown in Fig. 4. The Zn-2p_{3/2} peak appears at 1021.9 eV and that for Zn-2p_{1/2} appears at 1044.9 eV, confirming that Zn species is completely in oxidized state [11]. The peak is symmetric, indicating that no other species such as metallic Zinc is present, which would have shown a shoulder at ~1021.1 eV [11]. The core level photoemission peak of O-1s at

531.5 eV is attributed to the oxidized metal ions in the films, namely O-Zn in the ZnO lattice [12]. Along with Zinc and oxygen some amount of carbon was found in the samples, which might come from the precursor molecules.

B. TiO₂ Nanotube Arrays

Fig. 5 shows the SEM images of highly ordered TiO₂ nanotube array prepared under two different experimental conditions. When an electrolyte solution of (EG + NH₄F) was used for anodization of Ti foil, a film with highly ordered and close-packed nanotube arrays was formed. The approximate diameter and thickness of tube wall were 100 nm and several nanometers, respectively. The cross sectional and back-side (inset) SEM images of this film is shown in Fig 5(b). It is clear that the tubes are closely packed from the bottom of the film and the length of tube ranges from 2~3 μm. On the other hand, when (DEG + HF) was used as electrolyte solution, highly ordered TiO₂ nanotubes arrays is also observed but the tubes were arrayed separately with a certain distance (70~200 nm). The diameter of tube ranges from 150~200 nm and the thickness of the tube wall is several nanometers. The SEM image of the back side of the film shows that the tubes are separately formed from the bottom and the length of nanotube is 2 ~ 3μm.

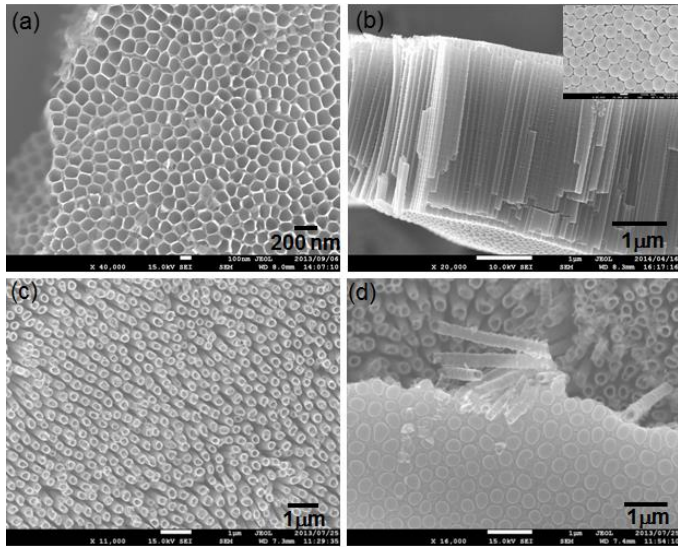

Figure 5. SEM images of TNA films prepared by different electrolyte solution: (a, b) NH₄ in ethylene glycol and (c, d) HF in diethylene glycol.

The chemical composition of TNA films (prepared from DEG+HF) was analyzed by XPS shown in Fig. 5. The Ti 2p spectra consists of two peaks at 458.7 eV (Ti 2p_{3/2}) and 464.3 eV (Ti 2p_{1/2}), which show that Ti is in the form of Ti⁴⁺. The peak at 530.5 eV (Fig. 6b) is attributed to O1s in the lattice oxygen of TiO₂ [13].

Fig. 7 shows XRD patterns of TNA films (prepared from DEG+HF) calcined at different temperatures. The as-anodized TiO₂ nanotube array presents an amorphous phase with peaks for titanium foil only. Two diffraction peaks at 25.28° and 48.05° are observed in XRD pattern of TNA annealed at 350°C for 2 h, which are according to (101) and (200) crystal faces of anatase TiO₂. With increasing temperature, the intensity of

anatase phase increases. However, a new peak at 27.45° appears for films calcined at 550 °C which indicates a phase transition from anatase to rutile.

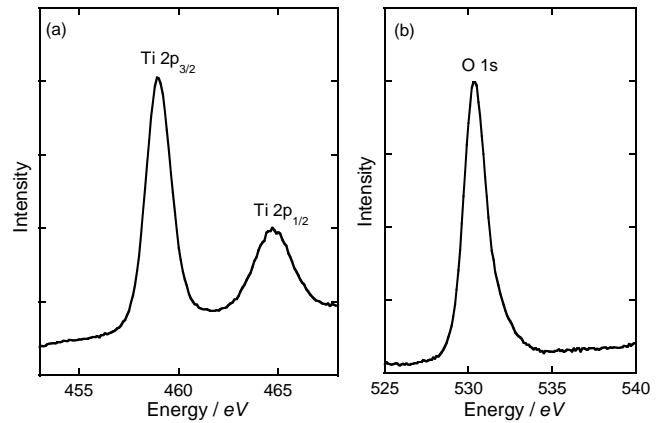

Figure 6. XPS spectra of TNA films; (a) Ti-2p region, and (b) O-1s region.

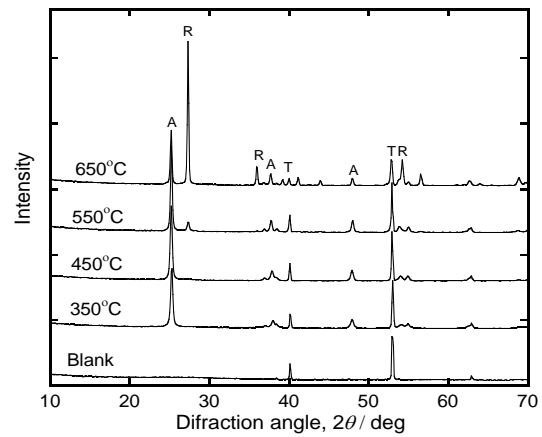

Figure 7. XRD patterns of TiO₂ films calcined at different temperatures (under N₂ atmosphere, calcination time: 2h).

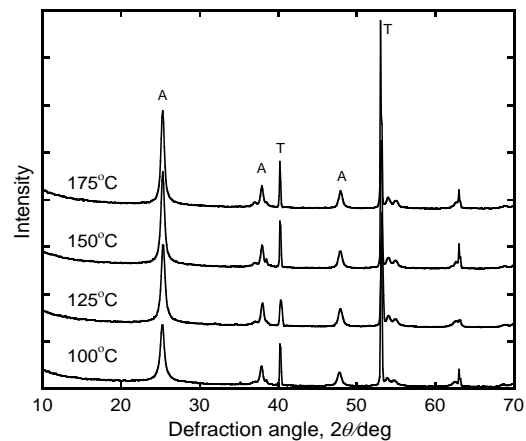

Figure 8. XRD patterns of TiO₂ films after hydrothermal treatment at different temperatures.

The TNA films (prepared from DEG+HF) also were subjected to hydrothermal treatment at low temperatures. Fig. 8 shows XRD patterns of TNA films treated at different

temperatures. At 100°C the peaks for anatase phase are observed and with increasing the temperature up to 175 °C, the intensity increases. This result indicates that hydrothermal treatment could be applicable to prepare high crystallized TNA films at low temperature.

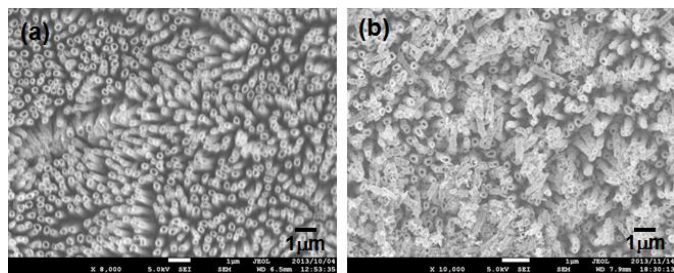

Figure 9. SEM images of TNA films after calcination at 650°C (a) and after hydrothermal treatment at 200°C (b).

SEM images of hydrothermal-treated and calcined TNA films are shown in Fig. 9. It is seen that structures of TiO₂ tubes are not affected by calcination at high temperature (Fig. 9 a) but around 50% of TiO₂ tubes were broken and disordered during hydrothermal treatment of the films (Fig. 9b). The reason of this result is still not clear and further research is underway in our laboratory. We are also working to evaluate the performance of ZnO and TiO₂ nanostructured films in electronic devices such as solar cells.

IV. CONCLUSIONS

We could control the size and morphology of nanostructured ZnO films by an easy and low cost technique. Simply changing the deposition temperature and time, different nanostructures (such as granular, plate-like whiskers, flower-like and multi-layer tower) of ZnO were obtained. Also, we successfully fabricated two types of TNA films by anodization method. According to morphological study, the EG electrolytes could produce the highly ordered, close-packed titania nanotubes, while DEG electrolytes could produce the separated nanotubes. Anatase TiO₂ nanotube arrays could be obtained at by hydrothermal treatment at low temperature. Further work on the performances of nanostructured ZnO and TiO₂ films are underway in our laboratory.

ACKNOWLEDGMENT

This research was supported by Improvement of Research Environment for young Researchers and Grand-in-Aid for Young Scientists (B) (No. 26810117) of the Ministry of Education, Culture, Sports, Science and Technology-Japan.

Also, financial support by Nohmura Foundation for Membrane Structures Technology in Japan is gratefully acknowledged. The authors thank Mr. Shigeyoshi Taira for XPS measurement.

REFERENCES

- [1] M. Fernandez-Garcia, A. Martinez-Arias, J. C. Hanson, J. A. Rodriguez, "Nanostructured oxides in chemistry: characterization and properties," *Chem. Rev.*, vol. 104, pp. 4063–4104, (2004).
- [2] R. Baranyai, A. Detrich, E. Volentiru, Z. Horvolbyi, "Preparation and characterization of ZnO and TiO₂ sol-gel thin films deposited by dip coating," *Hungarian Journal of Industrial Chemistry and Veszprem*, vol. 37, pp. 131-137, (2009).
- [3] T. Giannakopoulou, N. Todorova, M. Giannouri, Jiaguo Yu, C. Trapalis, "Optical and photocatalytic properties of composite TiO₂/ZnO thin films," *Catalysis Today*, In press.
- [4] I. K. Konstantinou, T.A. Albanis, "Photocatalytic transformation of pesticides in aqueous titanium dioxide suspensions using artificial and solar light intermediates and degradation pathways," *Appl. Catal. B: Environ.*, vol. 42, pp. 319-335 (2003).
- [5] B. Ahmmad, Y. Kusumoto, S. Somekawa, M. Ikeda, "Carbon nanotubes synergistically enhance photocatalytic activity of TiO₂," *Catalysis Communications*, vol. 9, pp. 1410-1413 (2008).
- [6] B. Ahmmad, Y. Kusumoto, M. Ikeda, S. Somekawa, Y. Horie, "Photocatalytic hydrogen production from diacids and their decomposition over mixtures of TiO₂ and single walled carbon nanotubes," *J. Adv. Oxid. Technol.* vol. 10, pp. 415-420, 2007.
- [7] D. A. Goosens, E.L. Maloney, J. Schoonman, "Gas-Phase Synthesis of Nanostructured Anatase TiO₂," *Chem. Vapor Deposition*, vol. 4, pp. 109-114 (1998).
- [8] N. Bagger, V.Georgieva, L. Calderin, I.T.Todorov, S. Van Gils, A. Bogaerts, "Study of the nucleation and growth of TiO₂ and ZnO thin films by means of molecular dynamics simulations," *Journal of Crystal Growth*, vol. 311, pp. 4034–4043 (2009).
- [9] C.Y. Liu, B.P. Zhang, N.T. Binh, K. Wakatsuki, Y. Segawa, "Temperature dependence of structural and optical properties of ZnO films grown on Si substrates by MOCVD," *J. Cryst. Growth*, vol. 290 p. 314-318 (2006).
- [10] K. Shankar, J. I. Basham, N. K. Allam, O. K. Varghese, G. K. Mor, X. Feng, M. Paulose, J. A. Seabold, K.-S. Choi, C. A. Grimes, "Recent advances in the use of TiO₂ nanotube and nanowire arrays for oxidative photoelectrochemistry," *J. Phys. Chem. C*, vol. 113, pp. 6327-6359 (2009).
- [11] F. Hirose, M. Ito, K. Kurita, "Low-Temperature Chemical Vapor Deposition of Anatase TiO₂ with Titanium Tetraisopropoxide and H₂O₂ Vapor," *Jpn J. Appl. Phys.*, vol. 47, pp. 5619-5622 (2008).
- [12] F. Jamal-Sheini, *Ceram. Int.*, "Chemical solution deposition of ZnO nanostructure films: Morphology and substrate angle dependency," vol. 38, pp. 3649-3657 (2012).
- [13] B. Ahmmad, Y. Kusumoto, M. S. Islam, "One-step and large scale synthesis of non-metal doped TiO₂ submicrospheres and their photocatalytic activity," *Adv. Power, Technol.* vol. 21, pp. 292-297 (2010).