

# Construction and Performance Study of Underground Assisted Air Heating and Cooling System

Md. Shazib Uddin, Mahadi Hasan Masud, S. Mandal and M. Morshed

Department of Mechanical Engineering  
Rajshahi University of Engineering and Technology  
Rajshahi-6204, Bangladesh  
E-mail: shazib0397@gmail.com

## Abstract

*This study presents the construction of underground assisted air heating and cooling system using four distinguish materials to investigate the comparative air cooling and heating effect for human comfort to discourage the use of traditional air conditioner in the living room. The system is installed 8ft depth from the ground surface and their length was 30 ft. The performances were investigated and recommend the better materials for the system. The results showed that the system is able to deliver cold air during summer season (mid of March) and hot air during winter season (mid of December) in line with the human comfort condition. PVC pipe perform better cooling effect compared to other pipe. The COP of PVC pipe found to 3.65 is quite attractive to use for the air conditioning purpose. The COP is lower for the other system. The system is simple, cost effective, environment friendly and easy to install can be used instead of air conditioner.*

Keywords: Conditioning of air, Underground system, Performance comparison.

## 1. Introduction

The demand of conditioned air for human comfort is growing worldwide. Air conditioning system is the most widely used system for conditioning indoor air to bring it under comfort level. The main component of this system is compressor consumes significant amount of electricity. Till now share of primary energy is dominating in the electricity generation sector in spite of alarming news regarding global primary energy crisis. So, researchers are suggesting the alternative way to meet the energy demand. In tropical country like Bangladesh, cooling of indoor air is growing due to increasing comfort expectations. Air conditioning is the most widely used cooling system for indoor air in Bangladesh in spite of facing a trouble of energy distribution due to the lack of availability. Researchers are working hard to find an alternative way to make the room air under comfort level. Underground assisted system so called earth tube is one of the methods to make the air for the expectation of human comfort. A new module was developed for and implemented in the Energy Plus program in USA for the simulation of earth tubes [1]. The model was validated and showed good agreement with both theoretical and experimental data. Using the new module, a parametric analysis was carried out to investigate the effect of pipe radius, pipe length, air flow rate and pipe depth on the overall performance of the earth tube under various conditions during cooling season. Pipe length and depth turned out to affect the overall cooling rate of the earth tube, while pipe radius and air flow rate mainly affect the cooling rate. The cooling and heating potential of earth tubes in four different locations were also investigated. This system showed more than 50% of cooling load could be possible to save. A study on earth tube was undertaken by Thevenard reported that earth tubes can provide between 30% and 100% of cooling needs, and only a small fraction of heating needs [2]. Zukowski et al. reported the computer simulation result and experimental investigation of thermal performance of earth tube heat exchanger. The study showed that the system can decrease the heating load and significantly reduce the room air during summer season [3] Darkwa et al reported that earth tube system made of PVC is able to contribute 62% and 86% of the peak heating and cooling loads respectively and corresponding COPs of 3.2 and 3.53. The average relative humidity level reduces to 10% in the heating period [4]. Hollmuller and Lachal studied the buried pipe system made of PVC for heating and cooling the air under central European climate. The study compared the cooling vs heating potential by the system [5]. Sharan and Jadhav reported the performance of single pass earth tube heat exchanger made of mild steel (MS) for heating and cooling the air [6]. The system was able to reduce the temperature of hot ambient air by as much as 14°C in May and warm up the cold ambient air by a similar amount in the nights of January. The coefficient of performance (COP) was found to 3.5. Deglin et al reported the earth tube performance made of non perforated PVC pipe [7]. Study showed that soil saturated in water, greater depth, smaller pipes and lower fan speeds are preferable to get better performance.

The review of existing literatures shows that the study was conducted using single type of material. The comparative performance study of different types of materials is unusual in the available literatures. The comparative experimental performance is important to select the suitable materials for this system. Addressing this research gap an experimental comparative study was undertaken in this paper to recommend the better material for the underground assisted heating and cooling system. The objectives of this study are to construct the system using different materials and performance evaluation among the materials and recommend the better materials for the system.

## 2. Construction

Four types of materials are available in Bangladesh namely, MS, PVC, PVC perforated available in the local market and bamboo were selected to construct the system. Ref. [2] reported that, length of the pipe is increase causes decrease the outlet air temperature and length can typically from 30 to 300 ft. In this system the length of the pipe is 30 ft used considering the cost and convenience for installation. The outlet air temperature increase with increasing the pipe diameter but thermal point of view smaller diameters are preferred. So, it needs a balance between them. In this study 1.5 inch diameter pipes were selected based on the cost and standard available in the market. Deeper positioning of the tubes ensures better performance. Typical depths are 4.5 to 9 ft used because at this depth the underground temperature remains constant in both summer and winter season. This study used 8 ft depth of the pipe was positioned under the ground. Lower flow rates are beneficial to achieve better performance. Typical flow rate is 3-5 m/s and the maximum flow rate was used in this study is 4.5 m/s. The circulation of the air is done using fan of 1.92 watt capacity and velocity measured by digital air flow meter. Digital hygrometer was used to measure the temperature and humidity. The sectional view of the setup is shown in Figure 1.

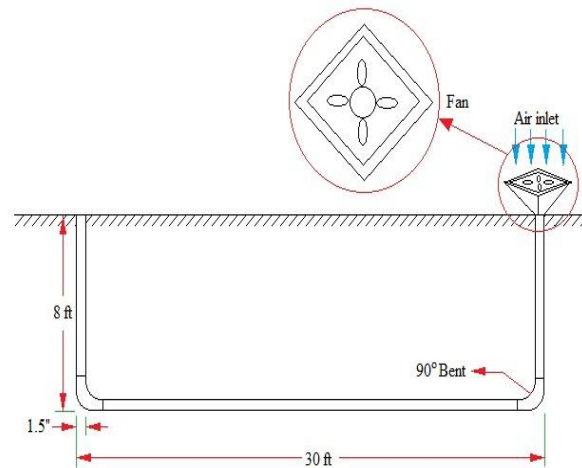

Fig. 1. Sectional view of the underground assisted air heating and cooling system

## 3. Results and discussion

The performance of the system was recorded at day time and night time of the winter season for the setup of four materials. Temperature, relative humidity and coefficient of performance (COP) were examined as these parameters are main responsible for human comfort and system performance respectively. The results of the experiment are described in the following sub sections.

### 3.1 Characteristics of temperature and relative humidity in the winter season

Figure 2 shows the behavior of temperature and relative humidity for the day time and night time of the winter season (mid December). It is seen that the temperature is increasing with time from the beginning of the day and maximum temperature is 27°C at 12.10 pm and then decrease with increasing time. The temperature is decreasing with increasing time at night time and minimum temperature is 17°C at 3.0 am. Relative humidity is maximum of 48% at morning and minimum of 36% at noon. This is due to the water droplet contents in the air is higher at morning and lower at noon. Similarly, relative humidity is increasing with increasing time at night time due to increase the water droplets in to the air and appear to constant humidity from mid night. The

maximum and minimum relative humidity at night time is 64% and 81% respectively. Hence, most of the people feel comfort under combination of 21°C dry bulb temperature and 40% relative humidity in winter season and 26°C dry bulb temperature and 40% relative humidity in summer season [8]. It needs effort to bring the temperature and humidity under comfort level.

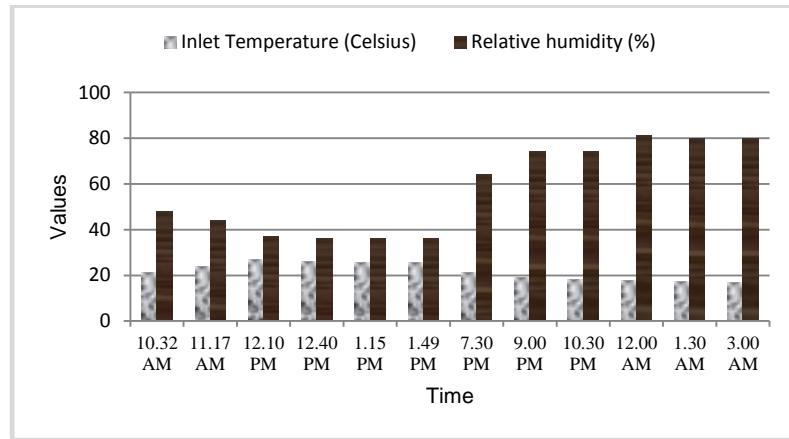

Fig. 2. Behavior of temperature and relative humidity in mid-December

### 3.2 Effect of system materials on exit air temperature

Figure 3 shows the outlet air temperature for four types of setup over day time. It is seen that the system with bamboo material is better to cool down the exit air temperature under same condition compared to other materials. The minimum temperature is 19°C provided by the system of bamboo. This may be due to the wood itself has moisture content that help to reduce the air temperature. The minimum temperature for the PVC, PVC perforated and MS materials are 23.2°C, 23.5°C, and 23°C respectively. Though bamboo materials shows better cooling effect but the other materials have shown the values are suit with close to comfort level also. The cooling performance of PVC and MS have shown similar trend over the day. It needs justification the relative humidity to recommend the better one for the human comfort. The observation at night time shows that bamboo materials show the minimum temperature is 19.2°C and minimum temperature for the PVC, PVC perforated and MS materials are 23.3°C, 24.2°C, and 23.2°C respectively. Hence, PVC and MS materials show very similar performance both in day and night time.

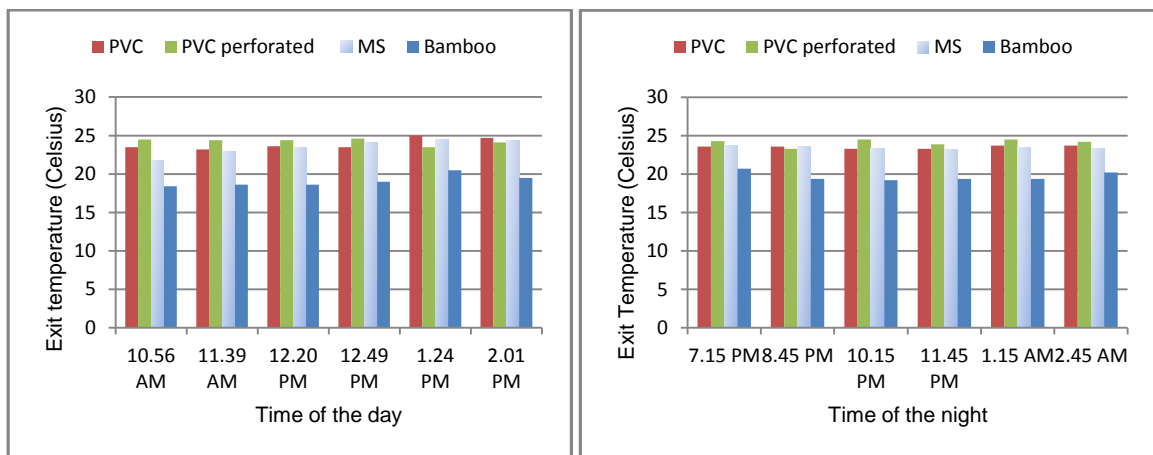

Fig. 3. Effect of system materials on outlet air temperature

### 3.3 Effect of system materials on exit relative humidity

Figure 4 shows the effect of system materials on exit relative humidity of the air with time. It is seen that the relative humidity is extremely higher and its values are more than 75% for the PVC perforated and bamboo materials which is not suitable for human comfort condition with comfort air temperature. This is may be due to

the moisture added from the underground soil for the perforated PVC pipe and moisture contents itself of bamboo materials. Relative humidity for the PVC and MS materials has shown better for the comfort condition values of 40-50%. Minimum relative humidity of PVC and MS materials are 39% and 41% respectively. Observation at night time shows that relative humidity for the PVC and MS materials are 47% and 48% respectively. Hence, PVC material is better to deliver comfort air for the occupancy. Its optimum combination for the day time is found to 23.2°C and 39% relative humidity and in night time is 23.3°C and 47% relative humidity is suitable for the conditioning of air.

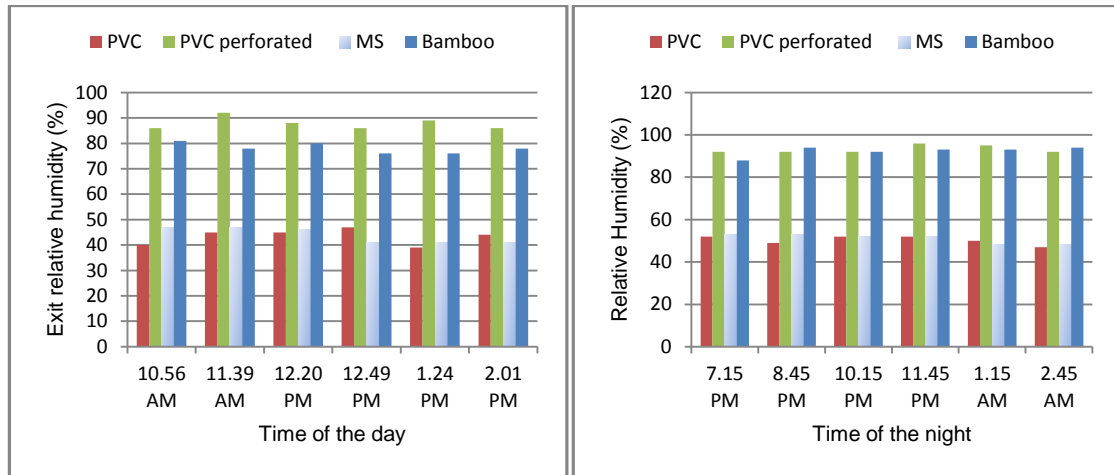

Fig. 4. Effect of system materials on outlet relative humidity of air

### 3.4 Effect of system materials on COP

Coefficient of performance is the ratio of the cooling effect to the energy input [2]. It is denoted by COP. The mathematical expression of the equation is

$$COP = \frac{Q_{out}}{W_{in}} \quad (1)$$

Where,

$$Q_{out} = m_a C_p (T_o - T_i)$$

$C_p$  = Specific heat of air ( J/ kg °C)

$Q_{out}$  = Cooling effect

$W_{in}$  = Energy input into the system by fan

$m_a$  = Mass flow rate of air ( kg / s )

$T_i$  = Temperature of air entering the pipe ( °C )

$T_o$  = Temperature of air at the outlet ( °C )

Mass flow rate,  $m_a = \rho \times A \times V$

$\rho$  = Air density (kg/m<sup>3</sup>) = 1.29 (For atmospheric condition)

$A$  = Cross sectional area of pipe (m<sup>2</sup>)

$V$  = Velocity of air at exit (m/s)

Figure 5 shows the effect of system materials on COP of the system. It is seen that at day time maximum COP for the PVC, PVC perforated and MS found to 2.91, 0.97 and 2.28 and at night time its values are 4.72, 3.98 and 3.45 respectively. The COP calculation for the bamboo materials was not possible due to extremely friction loss inside the passage made the outlet air velocity negligible and was not able to measure the velocity using air flow meter. The observation shows that the COP for the PVC material is found to better compare to other materials both in day time and night time. The maximum values of COP using PVC materials in day time and night time are 2.91 and 4.72 respectively. Hence, PVC materials can be used to bring the room air for human comfort with combination of 23.2°C air temperature and 39% relative humidity at day time and 23.3°C and 47% relative humidity in night time with COP of 3.84 averages in the winter season of Bangladesh.

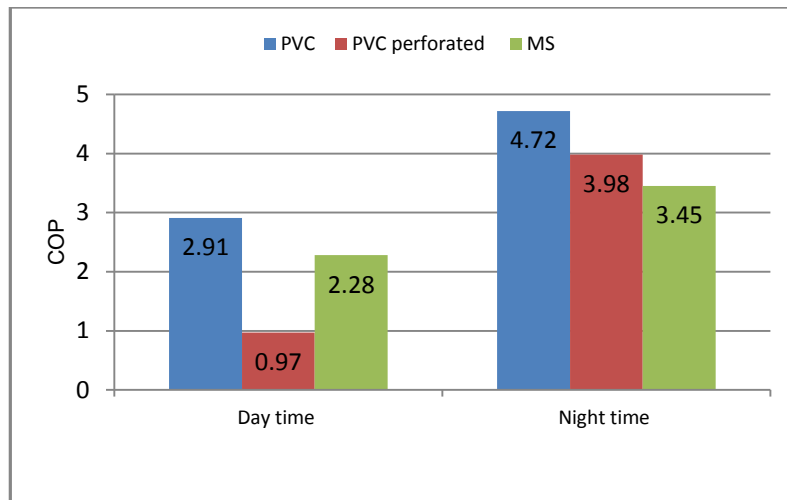

**Fig. 5.** Effect of system materials on maximum COP

### 3.5 Performance in summer season using PVC materials

Figure 6 shows the effect of PVC materials on outlet temperature and relative humidity in summer season. The performance was conducted in day time. The results showed that the inlet temperature of the system was above 30°C and the outlet temperature is almost close to 25°C over the day. It implies that the system is able to make down the high temperature air to low temperature as well as comfort condition. The inlet relative humidity of the system is almost lower than 15% and the system is able to deliver with the relative humidity of 20 to 30% which help to build comfort combination of the temperature and humidity.

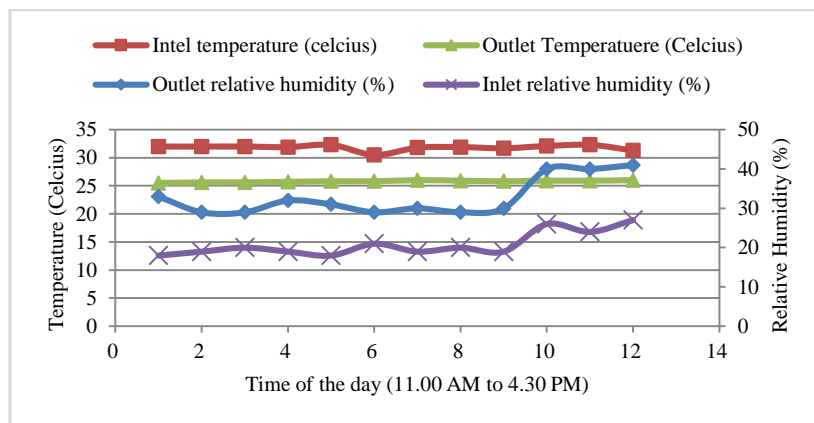

**Fig. 6.** Effect of PVC materials on temperature and humidity in summer season

## 4. Conclusions

An experimental study was undertaken in this study to make the room air under comfort condition using underground assisted heating and cooling system. PVC, PVC perforated MS and bamboo materials were used for the system and their performance compared. The result showed that PVC pipe is better compared to other materials to achieve the room air under comfort level. This study was investigated in winter season and the optimum comfort combination of outlet air temperature and relative humidity are 23.2°C and 39% in day time and 23.3°C and 47% relative humidity in night time respectively. The average coefficient of performance is found to 3.84 which is better for the application instead of air conditioner in the occupied room and will be able to make the room air under comfort level. The value of COP in this study is also higher than that of the

literatures presented in this paper of 3.5. The system could be used widely in the residential and industrial sector to minimize the fossil energy use in the context of energy crisis in Bangladesh and overseas.

## Acknowledgement

Author would like to thank the department of Mechanical Engineering, Rajshahi University of Engineering & Technology (RUET) for providing the fund and platform for this work. Author would like to thank Mr. GM. Ahteshamul Haque and Mr. Md. Nazmus Sakib Khan, Department of Mechanical Engineering, RUET for their effort and help to complete this work. Author would like to thank those who directly or indirectly help for the completion this work.

## References

- [1] R. K. Strand and K. H. Lee, 'Implementation of an Earth Tube System into Energyplus Program', Conference proceedings, University of Illinois, Urbana Campaign, USA, 2007.
- [2] D. Thevenard, 'Bibliographic search on potential of earth tubes', Numerical Logics Inc., Waterloo, Canada, 2007.
- [3] M. Zukowski, B. Sadowska and W. Sarosiek, 'Assessment of the Cooling Potential of an Earth-Tube Heat Exchanger in Residential Buildings, Conference proceedings, Vilnius Gediminas Technical University, Lithuania, 2011.
- [4] J. Darkwa, G. Kokogiannakis, C. L. Magadzire, K. Yuan, Theoretical and practical evaluation of an earth-tube (E-tube) ventilation system, *Energy and Buildings*,43(2):728-736, 2011.
- [5] P. Hollmuller, B. Lachal, 'Cooling and preheating with buried pipe systems: monitoring, simulation and economic aspects' *Energy and Buildings*, 1295, 1-10, 2000.
- [6] G. Sharan, R. Jadhav, 'Performance of Single Pass earth-TubeHeat Exchanger: An Experimental Study', Ahmedabad, Indian institute of management, 2003.
- [7] Deglin D, Van Caenegem L and Dehon P (1999) Subsoil Heat Exchangers for the Air Conditioning of Livestock Buildings. *J. Agric. Engng Res.* 73, 179-188.
- [8] American Society of Heating, Refrigerating, and Air-Conditioning Engineers, Effective Temperature and Human Comfort, Institute for Environmental Research at Kansas State University under contract to ASHRAE, <http://www.hvacairconditioningdesign.com/effective-temperature-and-human-comfort/>

## NGV Safety and Regulatory Regime -Challenges in Bangladesh

Robiul Islam Rubel

Department of Mechanical Engineering, Rajshahi University of Engineering & Technology, Rajshahi-  
6204, Bangladesh  
Email: rubel.ruet10@yahoo.com

### Abstract

*Natural gas driven vehicles (NGV) is common in Bangladesh first introduced around 1995 in Bangladesh. However, scenario has changed due to low cost of CNG as fuel. The government also encouraged the conversion of private vehicles by making several policy initiatives as Bangladesh has natural gas reserve, cost economy, low emission. Now passenger car, bus, agricultural vehicles are using CNG as fuel. Faulty cylinders or other CNG-related kits in NGV not only endanger the lives of the passengers of the vehicles, but also of others somehow remaining close to the accident spots. The safety aspect of CNG runs vehicles are beyond regular and strict monitoring, even out of consideration. The objective of this paper is to find out the present scenario of the NGV of Bangladesh and safety perspective in compare to the CNG safety act of Bangladesh. For this purpose, other CNG safety standard of first world country along with exporter country is under consideration. This paper reviews the options available to policy makers in their efforts to reduce the causalities associated with NGV transport. It provides a summary of the categories of negative impacts targeted together with the specific policy initiatives available. The actions for regulation taken by policy makers and foregoing challenges are underlined. To fight against the challenges a framework has proposed.*

**Keywords:** Safety Standards, Safety act, Regulatory Regime, Framework and Challenges.

### 1. Introduction

A natural gas vehicle or NGV is an alternative fuel vehicle that uses compressed natural gas (CNG) or, less commonly, liquefied natural gas (LNG) as a clean alternative to other automobile fuels[1]. The on-board storage capacity of natural gas vehicles (NGVs) is a critical issue to the wide spread marketing of these alternate fuelled vehicles. In Bangladesh, CNG is used as a NGV fuel because of its availability and cheap rate. During last decade, the consumption of a CNG is increased almost 25% in share. By 2020 it is predicted to increase its energy share to 50% from the present of 22%[2]. Michiel Nijboer[3] concludes that natural gas can cover almost the whole spectrum of vehicles, ranging from motorcycles, tuk-tuks (local name), cars, vans, buses, trucks, off-road vehicles, ships and trains, including even airplanes. Therefore, conversion of gasoline engine to NGV is increasing rapidly. This conversion will bring significant economic and environmental benefits of the country. It will reduce dependency on the imported fuels, increasing national security and lowering foreign trade deficit[4]. According to Jeewan V. Turkey[5], NGV offers certain advantages such as clean combustion (no lead or sulphur compound) due to high H/C ratio, does not contaminate and dilute the engine oil which forms no deposits on spark plug. It also offers advantage over gasoline in terms of its low density and readily miscibility with air, high knock resistance (octane number 120-130), lean burning capability. In present about 0.2 million CNG, driven vehicles are on service around Bangladesh including three-wheeler auto rickshaw, bus, private car etc. NGV safety strongly depends on design, materials, installation, operating conditions and maintenance. It is found that, all the vehicles have common system of CNG cylinder installation system that is quite dangerous, unacceptable from scientific view. However, due to lack of modification in available engines including supply of conversion kits, it is fully difficult to utilize the above properties of CNG powered engine to enhance the performance. Many fuel vehicles have converted as CNG driven without considering vehicles condition, road and equipment arrangement. In many case, local repairing shops do the work of conversion, whose have no knowledge about the safety. About 40% vehicles has no safety certified CNG cylinder, 17% locally converted as NGV. CNG is dispensed to an NGV through a process known as the fast fill process, since it is completed in less than five minutes. During fast fill, charging operations can occur under-filling of NGV cylinders, at fuelling stations[6]. Government of Bangladesh (GOB) has no statistics of CNG affair accident though it is escalating alarmingly. However, neither the official agencies nor the owners of the gas-run vehicles seem to be tense regarding safety and security issues to the extent they should pay. This paper focuses on the

most common form of use of CNG that is NGV, safety of the NGV as transport vehicles. Again, the recommendation available to-



**Fig. 1.**(a) Car with burned cylinder, (b) Porosity due to multi pass and over pressure

policy makers in their efforts to reduce the casualties associated with NGV transport is also discussed. Therefore, it provides a summary of the categories of negative impacts that can be targeted together with the specific policy initiatives available to safer theoperation of the NGV. The actions for regulation taken by policy makers and foregoing challenges are underlined. A framework has proposed to fight against the challenges for NGV safety and regulatory regime.

## **2. Methodology of the study**

The methodology of this paper is based on quantitative survey. The existence of basic components on the vehicles was observed in three sections. First, second and third section contained Essential, Safety, Optional parts respectively. During period of two month, 300 NGV was covered at various locations including capital Dhaka. We emphasized on CNG 3-wheeler auto rickshaw, emma (local name), bus and private car, as it would reflect the true nature of the survey. Diesel vehicles have been excluded from this study because diesel automobiles engine are not been converted in this country yet. Besides a brief interview with five gas station owners was undertaken to have their ideas and suggestion. Interview of the drivers was taken on some related issue, which helped to do the discussion more specifically. It was required to go through various literatures to get information regarding the issue mostly supplied by RPGCL, BRTA, BERC, Department of Explosives, Ministry of Power Energy and Mineral Resource Division, daily newspaper and TV reports etc.

## **3. Summary of findings**

The study astonishingly shows violation of NGV rule by drivers, owner including passenger also. One in ten NGV has no certified CNG cylinder; three in ten NGV has no safety fittings except pressure gauge, no training or technical support for the driver. Authority has no control over the situation. The identified problems are cylinder blast, leak gas explosion, lack of monitory board and so on. Only 20% of convertible vehicles are running by CNG. NGVs have a shorter traveling distance compared to traditional fuels vehicle. Many in-built (dedicated) CNG busses have been damaged within short period. In-built (dedicated) CNG three-wheeler from Pakistan, China, and Thailand has already been damaged within short period. Only Bajaj three-wheeler from India is playing well. However, its lifetime is short compare to two-stroke Bajaj three-wheeler. Navana Ltd. and Nitol Motors Ltd. already stopped importing in-built (dedicated) CNG vehicles. Casualties associated with CNG vehicles are increasing day by bay. Fig 1 shows the causes of NGV failures and Fig 2 shows some common phenomenon.



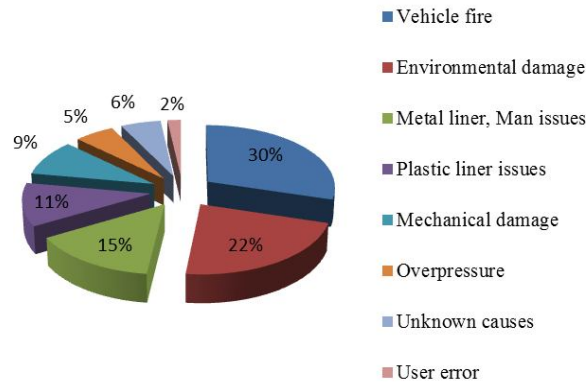

**Fig. 2.** Failure statistics

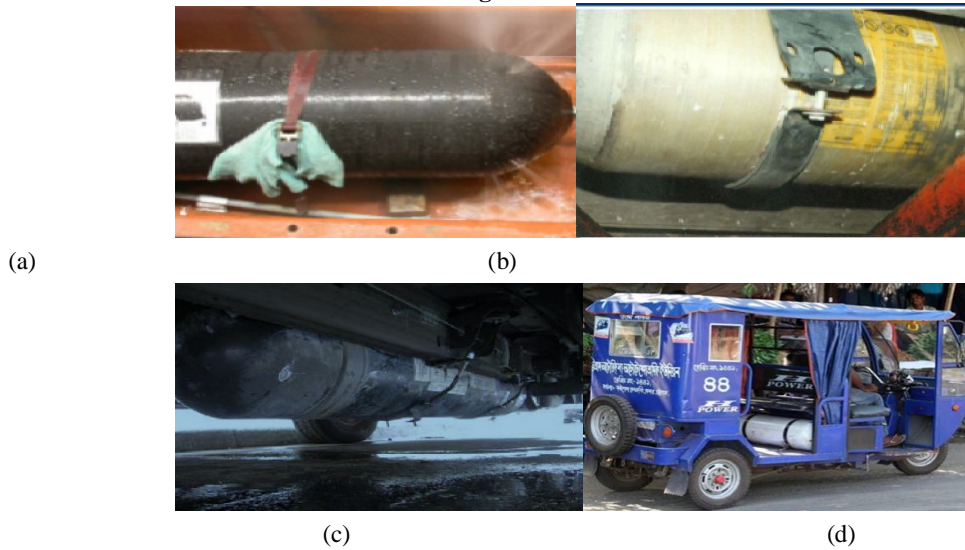

**Fig. 3.**(a) Cloth use for tightening the belt, (b) Improper nut-bolt setting, (c) Unprotected, protruding under floor cylindermounting, (d) Electrically driven auto rickshaw locally converted as NGV

### Cylinder failure

Common causes of CNG cylinder failure are (i) Long cycles service. (ii) Absent of valves, fittings, and/or pressure relief devices. (iii) Cylinders involved in collisions.(iv) Cylinders involved in fires due to smoking.(v) Chemical attack from passenger water bottle, lemon, cold drinks.(vi) Lack in-service inspection and periodic requalification. (vii) Use of sub- standard imported cylinder.(viii) Improper installation as shown in Fig 3(a), 3(b), 3(c).

### Risks and hazards from NGV gas cylinders

Gas cylinders can be hazardous due to both their physical (size and weight) and chemical characteristics. The common reasons are (i) Fire or explosion from the release of flammable gases near ignition sources (ii) Incorrect storage (iii) Leaks (iv) Faulty equipment set up (v) Physical risks (vi) Manual handling (vii) Sudden release of gas if cylinder is damaged (viii) Temperature rise of the cylinder. Table 1 shows safety components scenario of the NGVs running in the road.

**Table 1.** Required safety components scenario

Safety items	Comment on observation
--------------	------------------------

Pressure indicator or fuel level indicator	Yes
Pressure relief device	In some cases
Automatic cylinder valve	Yes
Manual valve	No
Pressure regulator	Yes
Gas flow adjuster	No/Inactive
Excess flow limiter	Yes but inactive
Filling unit or receptacle	Yes
Flexible fuel line	Yes
Electronic control unit	No
Temperature sensor	No
Fittings	Partially available

### NGV in enclosed parking

While a car parked, a gas release may occur due to a mechanical failure leading to a rupture, or a leak of the valve system of the NGV. A rupture may be caused by heat from a nearby car on fire or from a fire of smoking, spark. Therefore, safe parking place is an important factor to prevent blast.

### Filling station

Slow fill installations can give rise to dangerous conditions when placed in enclosed garages. In Bangladesh, maximum filling station has no safety phases to prevent firing from roadside smoking, even cooking arrangement, tea stall has found established within the gas filling station ground.

### Facility problem

Facility problem is a major reason of CNG related accident summarized in Table 2. The common causes are (i) Lack of authorized CNG conversion plant (ii) Lack of policy and regulatory framework (iii) Lack of skill technician and training program (iv) Unavailability of gas all over the country.

**Table 2.** Statistics of CNG Filling Station and Conversion Workshop in Bangladesh[7]

SI No.	Fiscal Year	No. of CNG Filling Station	No. of Conversion workshop	No. Converted Vehicles
1	2013-2014	0	0	6487
2	2012-2013	0	0	4382
3	2011-2012	0	0	5792
4	2010-2011	5	10	13343
5	2009-2010	119	29	28676
6	2008-2009	243	20	24516
7	2007-2008	85	13	22718
8	2006-2007	42	28	25974
9	2005-2006	23	31	26032
10	2004-2005	41	22	10135

### Safety acts and standards

NGVs are CNG fueled vehicles, thus discussed in CNG rules of Bangladesh. The rules are followed by the following sections (i) Safety Codes and Standard for CNG Fuel Systems for Vehicles- 2007 (Draft, Bangladesh Energy Regulatory Commission) (ii) Bangladesh CNG rules- 2005 (Department of Explosives; Energy and Mineral Resource Division; Ministry of Power Energy and Mineral Resources) (iii) The Liquefied Petroleum Gas (LPG) Rules- 2004. (iv) The Gas Pressure Vessel Rules- 1995 (v) The Natural Gas Safety Rules- 1991 (vi) The Gas Cylinder Rules- 1991. The Gas Cylinder Rules regulate, import, filling, possession of manufactured cylinders, valves, safety fittings used for cylinders containing compressed gases viz., permanent gas, liquefiable gas or gas dissolved in liquid for toxic, flammable, non-toxic, non-flammable nature etc. Under the Gas Cylinder Rules, different type of licenses and different types of approvals are granted. The license is required for importing cylinders, filling of cylinders with compressed gases, for storage of filled cylinders for LPG bottling plants and CNG filling stations. Approvals are granted for manufacture of cylinders, valves, regulators and safety fittings etc. Conversion of gas cylinders from one gas service to another gas service, recognition of cylinder testing station, hot repairs of welded/brazed cylinders also requires approval under CNG rules[8].

### Overseas CNG cylinder standards

Bangladesh imports CNG cylinder from India, China, Korea, and USA. Worldwide CNG cylinder standards are given in Table 3.

**Table 3.** Worldwide CNG cylinder standards[9, 10]

Supplier country	Standards	Comment
Germany, France, Italy,	ECER-110	ISO 11439, ECE R110 and NGV2 require the cylinder manufacturer to provide recommendations on installation, use and periodic requalification for their CNG cylinders.
Slovakia, South Korea,	ISO-110	
Thailand, USA, Pakistan,	ISO 11439	
India,	ANSI/CSA NGV 2	

### Overview of CNG cylinder standards

Standards such as ISO 11439, ECE R110 and NGV2 2000 criteria are achieved by(i) Specifying service conditions. (ii)Assessing the cyclic pressure fatigue life and establishing allowable defect sizes. (iii) Compliance with a set of design qualification tests.(iv) Requiring non-destructive testing and inspection of all production cylinders. (v) Requiring destructive tests on cylinders and cylinder material taken from each batch of cylinders produced.(vi) Requiring manufacturers to have a comprehensive quality system.

### BRTA action for fitness of CNG vehicles

BRTA is the legalized government authority to investigate the vehicles fitness. However, BRTA is not inspecting the equipment and fittings of CNG portion of the vehicle. For CNG portion of the vehicle, BRTA is issuing the conversion certificate of the conversion center i.e. BRTA is taking only the conversion certificate during issuing/renewing the fitness certificate. Before issuing/renewing the fitness certificate of CNG vehicle, BRTA makes correction of the fuel type as CNG in registration certificate. According to government decision,correction of fuel type in the registration certificate is not a mandatory for the vehicle,which has been converted from Petrol/Octane engine to CNG driven engine. Correction is mandatory only for the vehicles, which has been converted from Diesel engine to CNG driven engine [11].

### Challenges

Unfortunately, Bangladesh is a country where the tendency to break or ignore laws is very high. Some people indulge in the mischief deliberately and some others do it out of ignorance. However, the lack of solemnity on the part of the men in authority to enforce laws and punish the violators of the same has only been encouraging people to break laws. Nevertheless, immoral officials thrive as the violators of laws grease their palms. So act remain an act in book never comes true. Government is not encouraging conversion of vehicles, which are more than 8 years old [12]. Therefore, it is a great challenge so cope with the situation for the law enforcer.

### 4. Prevention method

Causalities relating NGV accident can lower by taking some preventive steps as shown in Fig 4, Fig 5. They are (i) Fencing the CNG cylinder. (ii) The maximum service life shall be 20 years. (iii) All components of the system shall be fastened in a proper way.(iv) The container shall be installed such that there is no metal-to-metal contact.(v) Developing system of retesting certificate.(vi) Use of gas cylinders in well-ventilated areas, not in confined areas. (vii) Disconnect empty cylinders from equipment to avoid backflow issues. The visual inspection should be performed by a competent agency approved or recognized by the regulatory authority, in accordance with the manufacturer's specifications. Cylinders without labels or stamps containing mandatory information or with labels or stamps containing mandatory information that is illegible in any way must be removed from service. If the cylinder can be positively identified by manufacturer and serial number, a replacement label or stamping may be applied, allowing the cylinder to remain in service. Cylinders involved in collisions should be re-inspected by an authorized inspection agency. Building new CNG industry is no exception. The Ministry of Power, Energy and Mineral Resources should look into the matters of safety and security related issues involving CNG cylinders, conversion workshops and filling stations and help to reduce the number of accident. Be insured about the other accessories by traffic department.

**Table 4.** For cylinder safety a summary of the do's/don'ts when working with gas cylinder

DO	DON'T
Ensure a regulator is fitted before use	Repaint a cylinder
Ensure cylinder is firmly secured	Change the markings on a cylinder
Ensure cylinders are stored away from ignition sources	Tamper with the gas cylinder test tag
Store full and empty cylinders separately	Remove the barcode from a gas cylinder
Ensure valve guards or caps are fitted	Roll cylinders along the ground
Use mechanical assistance when handling cylinders	Attempt to fight a fire involving a gas cylinder
Ensure adequate ventilation is available	Transport gas cylinders in the passenger

Ensure exposure limits are not exceeded	compartment of a vehicle Use a cylinder that shows evidence of damage
---	--

**Regulatory framework**

Department of Explosives, Ministry of Energy and Mineral Resources, Bangladesh Road Transport Authority, Bangladesh Energy Regulatory Commission are low enforcer and statutory bodies. The scopes of these bodies are statutes setting up the respective safety regulators. The decisions of the regulators may be challenged by judicial review under rules of the Gas, Cylinder and Articles. Transmission, distribution, NGV conversion, running in the road activities should requires permission from different govt. departments or organizations, including The Ministry of Energy and Mineral Resources, The Ministry of Law, The Department of Environment, and BRTA. The task of the framework will be insured the safe running of NGV by regular monitoring, growing awareness, arrangement training program and penalizing for the violator.



**Fig. 4.** Regulator outlet connection (1) and Cylinder value (2)

**Fig. 5.** Typical holding system

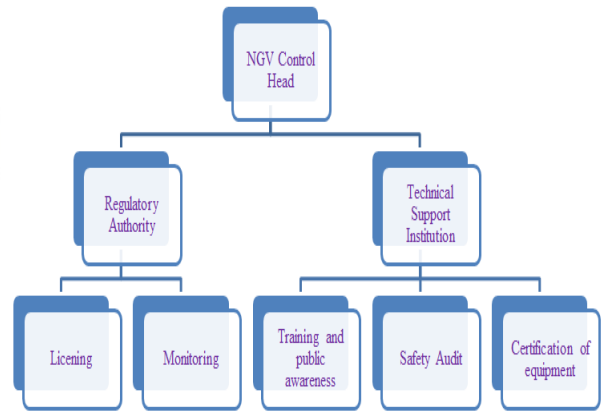
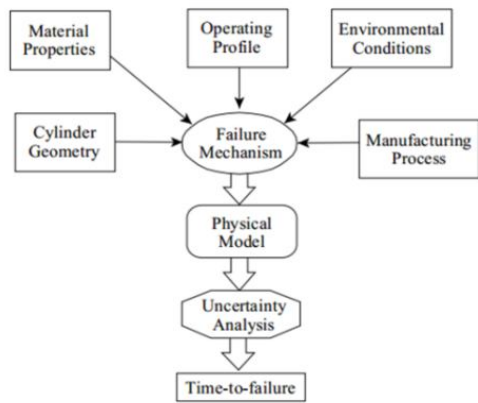

**Fig. 6.** Failure study process to prevent accident **Fig. 7.** Typical regulatory framework

**5. Conclusions**

The above study finds the present prospects of NGV interconnected with safety standard and interference on implementation. The existing situation is going to be crucial, if proper steps not taken in first hand. The NGV related accident becomes common. The regulatory framework appears ineffective. Therefore, revision of CNG act and restraint the law in all levels associated with NGV are the prime challenges. Only 20% of convertible vehicles are running by CNG and many are on conversion line. However, this is huge enough to eat up the facility available. Thus new infrastructure is essential to service this most economic and environmental friendly transportation system. For any policy making, the socio economic condition besides environmental impact must consider. The findings from this study can be used in any safety assessment to construction a monitory framework within Bangladesh. It may be generalized after consideration of certain limitations. The study-population was selected purposively as the data is not available in the respective departments. Actually, there was no specific sampling frame in order to find out the required data to conduct the research. This study considers only the active passengers carrying NGVs. Further research can be undertaken taking into consideration in other major metropolitan cities of Bangladesh.

**6. References**

[1] Information on [https://en.wikipedia.org/wiki/Natural\\_gas\\_vehicle](https://en.wikipedia.org/wiki/Natural_gas_vehicle) (8.5.2015).

- [2] A. M. M. Mukaddes, Bivek Bikram Adhikari, and Rakesh Kumar Sah, "Simulation Study on CNG Station Distributions in Intercity Network Using ARENA Software", *Proceedings of the International Conference on Mechanical Engineering (ICME)*, Dhaka, Bangladesh, 2011.
- [3] Michiel Nijboer, "The Contribution of Natural Gas Vehicles to Sustainable Transport", *Working Paper, International Energy Agency*, pp. 19, OECD/IEA, 2010.
- [4] Santosh A Jalihal, and T S Reddy, "CNG: An alternative fuel for public transport", *Journal of Science and Industrial Research*, Vol. 65, pp. 426-431, 2006.
- [5] Jeewan V. Tirkey, H.N. Gupta, and S.K. Shukla, "Analytical Study to Minimize The Engine Exhaust Emissions And Safe Knock Limit of CNG Powered Four-Stroke SI Engine", *IJEE*, Vol.1, No.1, pp.31-52, 2010.
- [6] Mahmood Farzaneh-Gord, "Real and Ideal Gas Thermodynamic Analysis of Single Reservoir Filling Process of Natural Gas Vehicle Cylinders", *Journal of Theoretical and Applied Mechanics*, Sofia, Vol. 41, No.2, pp. 21-36, 2011.
- [7] Information on [www.rpgcl.org.bd](http://www.rpgcl.org.bd) (Rupantarito Praktik Gas Company Limited, Bangladesh).
- [8] Information on Gazettes of Bangladesh (Energy Regulatory Commission; Department of Explosives; Ministry of Power Energy; and Mineral resource division), Government Republic of Bangladesh.
- [9] Mark Trudgeon, "An overview of NGV cylinder safety standards, production and in-service requirements", *Published by imambc in www.scribd.com*, July 20, 2012.
- [10] Robert Zalosh, "CNG and Hydrogen Vehicle Fuel Tank Failure Incidents, Testing, and Preventive Measures", *Firexplo, Wellesley MA*, bzalosh@firexplo.com.
- [11] Sk. Md. Mahub-E-Rabbani, "BRTA's Activities on Natural Gas Vehicles and The Prospects of getting dedicated Vehicles", *India Environmental Portal*, 20 Jan 2011.
- [12] Md. Shafiqul Islam, "Development of CNG infrastructure in Bangladesh", By Deputy Manager (CNG), RPGCL Bhaban, Plot no. 27, Nikunja-2, New Airport Road, Khilkhet, Dhaka-1229, Bangladesh, E-mail: shafique\_islam@yahoo.com.

## Feasibility Analysis of Eco-Friendly Municipal Waste Management in Khulna City

Debasish Adhikary<sup>1</sup>, Md. Shahidul Islam<sup>1</sup>

<sup>1</sup>Department of Mechanical Engineering, Khulna University of Engineering & Technology, Khulna-9203, Bangladesh.

E-mail: debasish06me@gmail.com

### Abstract

*The increasing population of Bangladesh leads to the growth of urban areas and slums which in turn, generating a huge volume of wastes. Thus disposal of waste has become a serious issue. Generation and characteristics of municipal waste in Khulna city, has analyzed along with the associated environmental impacts and existing municipal solid waste (MSW) practices. Main focus was given on feasibility analysis of municipal waste comparing with few alternative ideas. Evaluating those alternatives and find out the best possible way of energy extraction was the main purpose. Major portion of municipal solid waste of Khulna City in Bangladesh, is organic which are rapidly biodegradable and creating various environmental and health risk. At the same time the total daily household wastes generated in Khulna City areas is about 470 tons. Around 49 percent of total household wastes are managed. Because of unsatisfying solid waste management system in Khulna city, some common problems occurring such as diseases, fire hazards, odor nuisance atmospheric, water pollution and consequently economic losses. On the other hand, those wastes have a potential value of burnable biogas, generate electricity and organic bio-fertilizer. These potential factors convince us to compare few alternatives like Composting of organic waste, electricity generation waste burning and Biogas generation. In this context, to meet up the growing demand of bio-fertilizer, biogas and electricity, it is the best way to use renewable resources like municipal waste. It can help to minimize supply demand gap and create a modern well waste managed beautiful city as an example.*

**Keywords:** Municipal waste management, Eco-friendly, Bio-fertilizer, Electricity, Biogas.

### 1. Introduction

Municipal solid waste (MSW) is considered as one of the most immediate and serious environmental problems confronting municipal authorities in developing countries like Bangladesh. The rapid growth of urbanization and uncontrolled urban sprawl, severely degrade environment, natural resources and consequently undetermined equitable and sustainable development. Now it is a major global concern which is increasing day by day. Now is the time to motivate our policy makers, politicians, environmentalists, economists and also the government about the proper utilization of urban waste to save our city dwellers. However, effective utilization of solid waste requires sound setting of human resources and technical support. Waste disposing is an important part of solid waste utilization system, which requires much attention to avoid environmental pollution. In context of Bangladesh, waste disposal and utilization is in a bad shape in urban areas since urban inhabitants generate huge quantity of municipal waste daily and in such areas population density is high. Only major cities have some sort of garbage disposal system. In the major cities of Bangladesh, per capita production of waste is 0.5 kg/day but only 0.2 kg of waste per capita is carried to the final disposal [5]. The rest is disposed locally. This view of the major cities of any country obviously exhibits the poor waste utilization situation of that country. An integral management approach for household municipal solid waste has to address the overall flow of material through various waste utilization activities, such as - collection, transport, separation, reuse, recycling, composting, treatment, and final disposal. Municipal solid waste recycling and composting has been found to be acceptable as a sustainable approach towards the municipal solid waste utilization in environmental, economic and social points of view [4]. If municipal solid wastes are not recycled, the land filling up will be very fast and as a result, dumping site could be exhausted and necessitate the construction of new one. It reduces environmental damage, enhances income generation activity, saves energy, conserves resources, and saves waste collection, transportation and disposal cost.

#### 1.1. Objective of the study

- To find out the way to utilize the solid waste to generate compost/fertilizer, electricity, biogas and reuse of the society's resources
- Disclosing the existing Solid Waste Management practice in KCC

## **1.2. Methodology**

This research is mainly descriptive in nature. This type of research has discussed about the present status of Municipal solid waste (MSW) system and its prospects in social, economic life as well as in environmental development. Secondary data has been used to prepare this research. At the same time, various interviewed information were used in this research preparation which are collected through informal talking with the expert and people directly or indirectly related to waste management and its use related activities. In this respect, it can be said that both primary and secondary data have been used in preparing this research. Following three alternative ways came into consideration for this research.

- Resource recovers from organic waste by Composting as Bio-fertilizer.
- Prospects of solid waste in electricity generation.
- Energy extract from waste as Biogas.

## **2. Literature review**

Regarding the study entitled “Feasibility Analysis of Eco-Friendly Municipal Waste Management in Khulna City” there is not sufficient work in Bangladesh. Some research works conducted on some specific entitled topics. To grow concept, early ideas about the selected topic without the help of literature review is not possible. Various data, necessary materials can be collected from literature review. Sultana, T. (2006) stated the existing Municipal solid waste of Khulna City Corporation and determined the ecological footprint of waste generation of KCC area. She also recommended the way by which the ecological footprint of solid waste generation can be very effective tool for sustainable waste utilization in KCC area. Khulna Development Authority (KDA, 2013), this report stated that the daily collection efficiency of MSW (Municipal Solid Waste) is only 23 percent of the generated volume in KDA master plan area. The reason for low collection efficiency as stated in this report are insufficient funds to run the activities for collection and transportation of solid waste, insufficient number of equipment and carriers, insufficient number of road side rubbish bins, practice of improper use of bins and drains for waste disposal, insufficient maintenance staff and lack of public awareness on waste disposal system etc. Hoque, M.A. (2005), reported that the location of disposal (secondary) sites of KCC represent the unconsciousness about the environmental and public health hazards arising from disposing of waste in improper location. A suitable site must have environmental safety criteria's. Criteria for site selection include natural physical characteristics as well as socioeconomic, ecological, and land use factors. The Geographical Information System (GIS) can provide an opportunity to integrate field parameters with population and other relevant data or other associated features, which help in selection of suitable disposal sites. Salequzzaman (2005), stated that, Khulna city is reported to generate some 200-370 tons of wastes daily, per capita per day generation variously quoted lying between 0.22 kg and 0.75 kg. The city has a population of about 1.5 million. In Dhaka, per capita waste generation per day is 0.52 kg. Assuming the same value for Khulna, daily waste generation should be more than 750 tones which are sufficient for setting up a power plant about 3 MSW (Megawatt). To the knowledge of the consultant of this report, there has been no study on the quality assessment of Khulna city waste. Kashem (2007) stated in his research that, if the municipal solid waste which is generated in Khulna city is managed properly, it can be a potential resource. By using waste, biogas can be produced and the residue of biogas can be used as compost fertilizer and the produced biogas can be used as a means of producing electricity. In this way, potential resource can be recovered through waste utilization which is highlighted in his research.

## **3. Existing Municipal solid waste process in KCC**

### **3.1. Generation of municipal solid waste**

There is no reliable estimate about the amount of solid waste generated in the city. Generation of solid waste may vary with the income of people, household size, season of the year etc. It has been estimated that municipal solid waste generation in KCC is 470 ton per day [4]. On this basis the quantity of solid waste generated per capita/day is 0.5 kg [2]. The main source of waste is households [2]. In Khulna city total household are about 0.2 million [11]. Highest quantity of solid waste is generated in winter season and lowest in wet season. About 70 to 80 percent of the generated waste in city is organic in nature and rest 20 percent is inorganic in nature [2].

### **3.2. Primary collection and Secondary collection**

KCC has a collection area of 45.65 sq. km. with total number of conservancy staff about 358 and 1200 dustbins [2]. There are minimum 10 to 20 dustbins in each ward [2]. Some of the dustbins are open at the top and some are covered. On realizing the present situation, it handed over some responsibilities of taking solid wastes from house to house collection of some wards to the several NGO (mainly Prodipan) [8]. The secondary collection means, after primary collection, the primary collection blocks are served by transport points and taken to the final disposal point by a large truck. KCC estimates about 470 ton of wastes are generated daily in the city area and only 120 to 125 ton are collected by it workers and the remaining are dumped irregularly [4]. KCC has 65 secondary disposal sites and some disposal sites are placed with demountable container, from where workers collect wastes with recommended KCC vehicles to the final disposal site in a regulated timetable. It has regular 22 to 25 trips to the final disposal site daily [2]. Rajbandh is the main dumping station of the KCC [2].

### 3.3. Collection system of private organization

Door to door collection systems are adopted for solid waste collection from generating sources and then dispose major portion of to the nearest secondary disposal system (SDS) [11]. NGOs and Community Based Organizations (CBOs) collect waste from approximately 28 to 30 thousands households [7]. Among the total generated waste of 420 - 470 tons per day, only 240 to 260 tons are transferred and disposed from SDS to Ultimate Disposal Site (UDS) by the city authority. Waste collections from sources and disposed in SDS by NGOs and CBOs are 40 to 50 tons per day, which is 9 % to 12% of the total generated solid waste [11]. The remaining solid wastes are collected from sources by city authority, private organization and drop to secondary points by householders and remain unmanaged [3]. In this collection process normally 71 vans are working daily without any day-off. Each van provides double trip per day having an approximately capacity of 270 kg/van/trip [7].

## 4. Feasible Eco-friendly municipal waste management systems

### 4.1. Resource recovers from organic solid waste as Bio-fertilizer (Composting)

Composting is the controlled bio-degradation of organic matter, usually under amebic conditions, by which a material is transformed into compost. Compost is the stable aid product derived from biological degradation of organic material, which can vary from dead leaves and roots to kitchen waste and vegetable remains under controlled conditions. If properly decomposed, compost is free from odor and pathogen free brown mixture which can be used as soil conditioner. Compost increases the efficiency of plant nutrient uptake, water-holding capacity of soil and soil aeration. Compost helps to increase better nutrient distribution and retention by the soil. Factors in favor of composting as a resource recovery option for Khulna city are 78 % of total generated solid waste in Khulna. Moisture content of 50% to 60% is optimum for aerobic composting. The typical moisture content of Khulna city is 55%, which is within the acceptable range for composting. Table 1 shows present composting plants in Khulna city.

**Table 1:** Details of composting plant in KCC area [1]

Name of the NGOs	No. of Plant	Plant size (m <sup>2</sup> )	Land ownership	Maturation period (days)	Unit price (Tk/kg)	Manpower involved	Special provision
		899	Self	50			
PRISM Bangladesh	04	360	Self	50	6	10	Waste water treatment project
		360	Self	50			
		540	Self	50			
PRODIPAN	01	733	KCC	60		6	
RUSTIC	01	614	Self	50		5	

### 4.2. Composting strategy for Khulna city

It has shown that in developing countries, large centralized and highly mechanized composting plants have often failed to reach their target and had to be abandoned due to high operational, transport and maintenance costs [5]. In many cases, small-scale decentralized communal composting plants may be considered as a suitable option for treating municipal solid waste as they reduce transport costs, make use of low-cost technologies, based mainly on manual labor and minimize problems and difficulties encountered with backyard composting.

### 4.3. Land, number of plants, manpower and investment requirements for composting



Table 2 shows land required for composting as well as number of plant and manpower required for this purpose. In total 13.24 bighas of land is required for composting of all the organic waste generated in Khulna city. For composting, fresh organic solid waste is necessary as raw material which can be collected by introducing house-to-house collection of solid waste. 300 workers are required for operating decentralized compost plants effectively [9]. These workers should have basic knowledge of different steps involved in composting process such as pile formation, temperature and moisture control.

**Table 2:** Land, manpower and estimated cost involvement for installation of different capacity of decentralized composting plant in Khulna

Items	Capacity of composting plant		
	3 ton/day	10 ton/day	20 ton/day
Land require/ plant (katha)	5	16	33
Fixed cost/plant(Tk)	5,16,640	17,22,133	34,44,266
Operating cost/plant(Tk)	344,600	1,148,666	22,97,333
Total Labors/plant	6	20	40
Compost produced (daily)	750kg	2500kg	5000kg
Expected revenue from sale of compost(Tk)	600,000	2000,000	4,000,000
Number of plants required	50	15	7

#### 4.4. Landfill gas to power generation

It is a traditional method to process solid waste. This system has been used to generate power in Australia, USA and Europe, though the amount of gas less than that produced with other technologies. This technology is suitable for Khulna city solid wastes because of high moisture content and low energy content solid wastes at scale of 470 tons per day. Under this method anaerobic digester for bio gas generation has to be used. Anaerobic digester is a leak-proof digester to produce gas for subsequent use. Figure 1 shows the basic procedure to produce electricity from municipal solid waste.

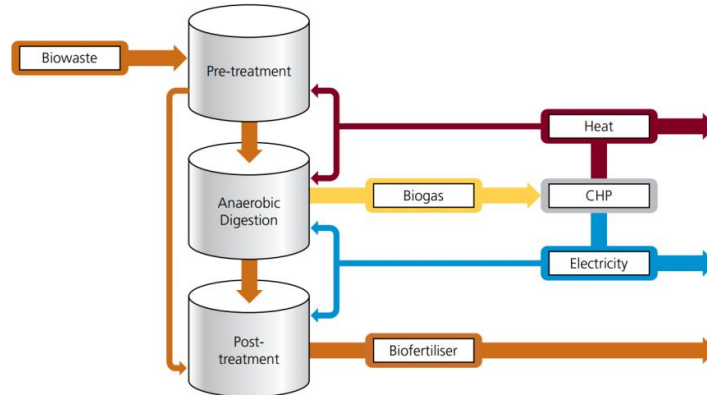

**Fig. 1:** Process of power generation activities

After digestion, scavengers with necessary safety measures will be employed to separate the remaining recyclable materials. Biogas does not have any leachate problem. It leaves a residue for use as soil conditioner and with biogas burning is uniform. So, there is no need of additional supply of gas from other source.

#### 4.5. Cost consideration

Though electricity can be produced from solid waste but its production cost is higher than usual production of electricity. As we produce electricity from solid waste, with the subsidy of government, we can sell per unit of electricity at taka 6 where Power Development Board sell electricity at taka 4. If we are producing electricity from solid waste, we are able to supply it to different organization during load shading period. These organizations are mainly depending on generator base electricity supply during load shading. So, they are very much eager to buy this electricity at price six which is lower than generator based electricity supply.

#### 4.6. Energy extract from solid waste as Biogas

Different organizations both government and non-government are involved in disseminating the biogas technology throughout the country. Total number of biogas plants in the country is about 25000 [12]. So far Bangladesh Council for Scientific and Industrial Research has installed about 22000 biogas plants in the country. Besides, Local Government Engineering Department (LGED) has installed about 1167, Bangladesh Rural Advancement Committee has installed about 1200, Grameen Shakti (GS) has installed 500 and Department of Environment has installed about 260 biogas plants in the country [7]. However, the number of biogas plants in the poultry sector is not significant.

#### 4.7. Cost-benefit analysis for biogas plant

MSW based anaerobic digestion plant may be small scale or large scale. For small scale, it may set up for family and for large scale, it may set up beside a dumping site where produced gas can be converted into electricity and this electricity can be supplied for city dwellers. Anaerobic digester's cost varies widely. Table 3 shows fixed cost and operational cost of a biogas plant. At the same time, Table 4 shows earning and cost-benefit analysis of it.

Item (a)	TK.	Item (b)	TK.
Construction of cost of 3 m <sup>3</sup> biogas plant	30,000	Salary of six worker and Tk. 2000 per month	1,44,000
Construction cost of sorting platform with shed	45,000	Salary of two van driver and Tk. 1500 per month	36,000
Construction cost of office and toilet facility	50,000	Salary of four waste collectors and Tk. 800 per month	38,400
Purchase of 3 rickshaw van of TK.15000 each	45,000	Salary of plant manager and Tk. 6000 per month	72,000
Water and electricity connection	50,000	Electricity and water bill	5,000
Equipment's for composting, dress for workers	50,000	Raw materials for biogas	12,000
Total fixes cost	2,70,000	Depreciation cost	27,000
		Total operational cost	3,34,400

Item (a)	TK.	Item (b)	TK.
Sale of biogas from plant 18 m <sup>3</sup> /day and TK 5/ m <sup>3</sup>	32,850	Total fixed cost for first year	2,70,000
Sale of bioelectricity from biogas 27 kwh/day and TK 5/ kwh	49,275	Total operational cost for the second and subsequent years	3,34,400
Sale of compost 100 kg from processing 400 kg of waste per day and TK 6/kg	2,19,000	Total earning per year	4,21,125
Monthly charge for house to house waste collection service rendered and TK 20/ household from 500 households	1,20,000	Average cost /benefit ratio considering 30 years project	1.23
Total Earning	4,21,125	Production cost of 1 m <sup>3</sup> biogas (considering 30 years project)	3.5
		Selling price of 1 m <sup>3</sup> of biogas	5
		Selling price of 1 kwh electricity	5
		Selling price of 1 kg fertilizer	6

#### 4.8. Comparison of unit cost

The production cost of 1 m<sup>3</sup> of biogas from cow dung based biogas plant is 8.25TK.

The production cost of 1 m<sup>3</sup> of biogas from MSW based biogas plant is 3.5TK.

#### 5. Findings

Findings are very essential part of a research. In findings, not only the prospective things of the research are highlighted but also the problems that a researcher faces during conducting the research. Despite facing some problem to collect data, some interesting findings came into light.

- All of three alternative ways are suitable for MWM in Khulna but combination of two or three of them will be more efficient energy extraction process.
- Municipal solid waste contains various compositions with specific merit of each. So solid waste need to be separated with its merit and use as specific energy extraction process.
- All three processes are viable in Khulna city for specific kind of solid waste.
- Production of compost, biogas and electricity helps to protect the open decomposition of organic waste that contributes to air pollution.

- Production of electricity reduces greenhouse gas emissions.
- Small scale community based compost plants can save 15 acres of landfill area per year.
- More than 40 tons of organic compost can be produced in Khulna city if the total generated organic waste is recycled every day. The decentralized community based composting plants can generate employment for the poor, especially the women, and offers new prospects for small entrepreneurs to take part in recycling business.
- By using 415480 kg of solid waste, 1445.2 m<sup>3</sup>/day biogas can be produced easily.
- Using this generated gas can produce 1, 93,408.55 MJ/day energy.
- On the other hand, there are various types of generator that are used to convert this biogas into electricity (around 22,126.11 kWh).

## 6. Conclusion

Existing solid waste generation is a burden for its dumping due to lack of dumping sites of Khulna city. But Khulna City Corporation's waste is increasing with the increasing of population. Thus it is crucial issue for Khulna City Corporation (KCC) authority and this is the time for making strategic plan on how growing burden of municipal solid waste is to manage significantly with innovating technologies. On the other hand, KCC along with the whole country is passing absolutely shortage of electricity. In addition, south-western Khulna region has no gas supply for cooking purpose where almost rest of the country is enjoying gas facilities. In this situation, MSW has a great significance to produce extra gas as well as ecologically sustainable organic bio-fertilizer from the biodegradable solid waste by using the anaerobic digestion process. This amount of electricity, bio-fertilizer and biogas can contribute in the economy by saving the extra money and minimize supply demand gap. Beside this, by processing the large amount of municipal solid waste, it is possible to maintain environment in a better way. Thus the environment will get rid of from the hazardous impact of waste and produced gas, electricity and bio-fertilizer will met the daily energy demand of Khulna city dwellers.

## 7. Acknowledgements

I would like to express my gratitude to my honorable head of the department Prof. Dr. Nawsher Ali Moral and my project supervisor Dr. Md. Shahidul Islam, Associate Professor, Department of Mechanical Engineering, Khulna University of Engineering & Technology. His keen guidance, moral as well as logistic support and continuous supervision made me possible to bring out this research.

## 8. References

- [1] Enayetullah, I.; Sinha, A.H.M.M., "A Study on Resource Recovery from Solid Waste in Khulna City," The World Bank, Dhaka, Waste and Sanitation Program in South Asia 2000.
- [2] "Annual Report," Khulna City Corporation (KCC), Khulna, 2012.
- [3] Salequzzaman, M., Iqbal, A. and Amin, M.N., "Contexts and Prospects of Renewable Energy Resources in KCC Area : A Case Study of Waste to Electricity from Existing Solid Waste," PREGA Training Workshop, Khulna, 2005.
- [4] "Detailed Area Plan for Khulna City," Khulna Development Authority (KDA), Khulna, 2013.
- [5] Sultana, T., Salequzzaman, Iqbal, A. and Hoque, A., "Ecological footprint of waste generation as a sustainable tool for solid waste management in the Khulna City Corporation of Bangladesh," in *International Conference on Complex Systems (ICCS2006)*, Boston, MA, USA, 2006, pp. 6-8.
- [6] M., Bidlingmaier, W., Glawe, U., Martens, J., Sharif, L. A., Visvanathan, C., Alamgir, "Safe and Sustainable Management of Municipal Solid Waste in Khulna City of Bangladesh," International Waste Management and Landfill Symposium, Cagliari, Italy, 2007.
- [7] PREGA National Technical Experts, "Quantity and Quality Assessment of Khulna City Solid Waste for Electricity Generation," ADB (Asian Development Bank), Bangladesh, 2013.
- [8] M.A. Hague, "Site Suitability Analysis for Solid Waste Disposal Using GIS: A Case Study on KCC area," Khulna University, Khulna, Graduate Thesis 2005.
- [9] A. Kashem, "Potential Resource Recovery from Municipal Solid Wastes of Khulna City Corporation Bangladesh," Khulna University, Khulna, Graduate Thesis 2007.
- [10] Mst. Sabikunnahar, "Cost — Benefit Analysis of Solid Waste Management of Khulna City Corporation," Khulna University, Khulna, Graduate Thesis 2006.
- [11] KCC & SDC, "Community Based Pilot Project on Solid Waste Management in Khulna City," KCC, Khulna, 2000.
- [12] Documentation and Publishing Wings, "Statistical Yearbook of Bangladesh," Bangladesh Bureau of Statistics (BBS), Dhaka, 2012.

## Implementation of a Solar Powered Desiccant Air Conditioning System

Shaikh Sumit Noor<sup>1</sup>, Al-Barkat Mehedi<sup>2</sup>, Fazla Hossain Mohaimen<sup>3</sup>

Department of Mechanical Engineering, Rajshahi University of Engineering & Technology,  
Rajshahi, Bangladesh.

Email: <sup>1</sup>sumit73@live.com, <sup>2</sup>albarkatme12@gmail.com, <sup>3</sup>fajlahossainsojol@gmail.com

### Abstract

*At present, the increasing use of conventional air conditioning system has led to more stress on power grids. Moreover the system requires components which are hardly economically feasible. These reasons elucidate the need of a financially viable air conditioning system which utilizes renewable energy. This paper describes the implementation of a proposed solar powered desiccant air conditioning system for residential and commercial applications. The system differs from the conventional thermal cooling systems in the sense that it requires inexpensive regenerative desiccant (i.e. Calcium Chloride) and low-temperature solar thermal collector. A flat plate solar collector absorbs sun's radiation and vaporizes the water from the salt solution leaving a concentrated solution behind which simultaneously works as a low cost energy reservoir. The desiccant solution is then kept in a container till cooling is required. A cooling unit comprised of three optimal heat exchangers materializes the dehumidification and cooling from the phase change phenomenon of the liquid desiccant and supplied water accordingly. In case of the lack of sunlight, off-peak electricity and natural gas can be used as alternative heat sources. The implementation of an economically feasible air conditioning system is the sole objective of this study.*

**Keywords:** Flat Plate Solar Collector, Regenerative Desiccant, Heat Exchanger, Absorption Air Conditioning

### 1. Introduction

Ever since the industrial revolution in the 18<sup>th</sup> century, the emission of greenhouse gases has increased abruptly resulting in global warming. The impact of this temperature rise is nevertheless detrimental to our communities, our health, and our climate. More frequent and intensified heat waves have been observed throughout the world than the last 60 years, specially in South Asian countries. These increased heat waves create critical health risks, and can lead to heat exhaustion, heat stroke, and deteriorate existing medical conditions. In June, 2015 death tolls rose over two thousand in Pakistan due to severe heat waves. The widespread usage of air conditioning units is the only imaginable solution to this unavoidable circumstance. Air conditioning facilitates the optimum humidity and maintains suitable temperature for human comfort. The conventional air-conditioning systems are subjected to high cost manufacturing and consumes extensive amount of power. In developing countries like Bangladesh these conventional systems are not affordable for the general people. In these circumstances implementation of an economically feasible air-conditioning system is essential. The power grid crisis in Bangladesh is evident and the utilization of alternative power resources is essential to mitigate this crisis and at the same time prevent environment pollution. Air conditioning units powered by solar energy is quite implementable in this scenario. On the average the amount of solar energy that reaches the earth is 1700 Btu/ft<sup>2</sup> or 5300 Wh/m<sup>2</sup> in a moderately radiant day. This paper describes the mechanism and working principle of an air conditioning system which utilizes this solar energy and ensures economic feasibility by using inexpensive flat plate solar collector and a low-cost desiccant.

### 2. Vapor Compression Refrigeration System

The flow of refrigerant through the compressor raises the refrigerant's pressure. Then the refrigerant flows through the condenser which causes a phase change from vapor to liquid and subsequently gives off heat. In the third stage, the refrigerant passes the expansion valve and experiences a pressure drop. Finally the refrigerant enters the evaporator where it is vaporized again. The evaporator receives heat from the region that requires cooling. The vaporized refrigerant then flows back to the compressor which initiates the cycle again.

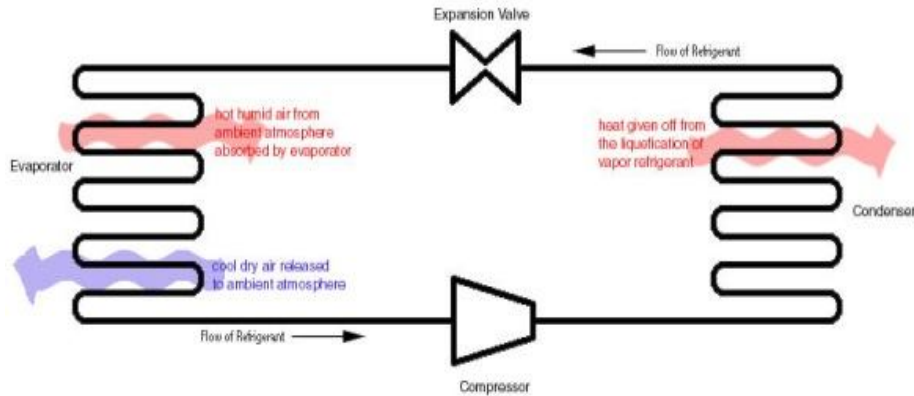

**Fig. 1.** Vapor compression refrigeration system.

### 3. Absorption Refrigeration System

This system differs from the vapor compression system in the sense that this operates on heat energy rather than mechanical energy. The condenser and evaporator are similar to the other system. However, a generator, pump and absorber are used instead of the compressor. The heat source causes the vapor refrigerant to boil and raises its pressure. The highly pressurized vapor is condensed at a higher temperature and pressure compared to its surrounding. Thus the heat is gets rejected from the condenser to the surrounding. The highly pressurized liquid then flows through the expansion valve which results in a pressure drop. The boiling point temperature subsequently falls and then it's passed through an evaporator. The liquid absorbs heat from the conditioned air which results in its evaporation. This causes the air to be cooled. The vapor is then flown through the absorber where it turns into liquid desiccant solution. Then the solution is pumped back into the generator by the pump. The heat separates the absorbent from the water. The water vapor enters the condenser while the desiccant goes to the absorber. This process is repeated continuously and results in cooling of the supplied air.

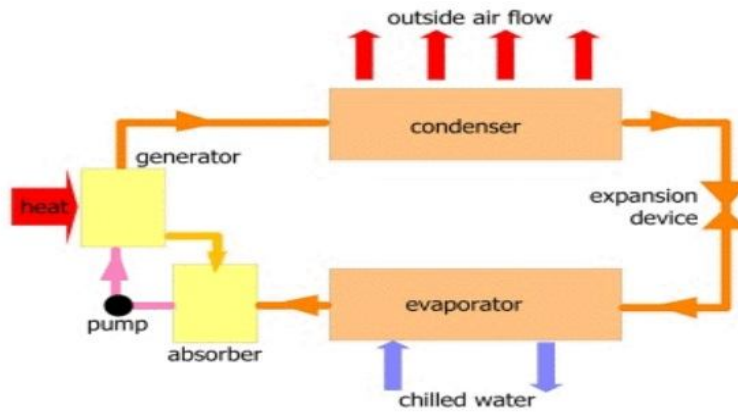

**Fig. 2.** Absorption refrigeration system.

This system differs from the vapor compression system in the sense that this operates on heat energy rather than mechanical energy. The condenser and evaporator are similar to the other system. However, a generator, pump and absorber are used instead of the compressor. The heat source causes the vapor refrigerant to boil and raises its pressure. The highly pressurized vapor is condensed at a higher temperature and pressure compared to its surrounding. Thus the heat is gets rejected from the condenser to the surrounding. The highly pressurized liquid then flows through the expansion valve which results in a pressure drop. The boiling point temperature subsequently falls and then itA's passed through an evaporator. The liquid absorbs heat from the conditioned air which results in its evaporation. This causes the air to be cooled. The vapor is then flown through the absorber where it turns into liquid desiccant solution. Then the solution is pumped back into the generator by the pump. The heat separates the absorbent from the water. The water vapor enters the condenser while the desiccant goes to the absorber. This process is repeated continuously and results in cooling of the supplied air.

## 4. Solar Air Conditioning

### Photovoltaic solar cooling

This system requires photovoltaic (PV) cells which are ten times more expensive than the conventional air conditioning systems and requires a large space for the supply of sufficient electrical power to operate an air condition.

### Passive solar cooling

This system requires the overall transformation of the structure of the buildings. The building materials are to be specified, the airflow needs to be controlled to ensure the removal of unwanted heat.

### Solar A/C using desiccants

The basic idea is to use regenerative desiccant to dehumidify the incoming outside air and provide a cooled air stream into the space that requires cooling. Silica gel, zeolites, lithium chlorides are commonly used desiccants but prove to be rather expensive.

## 5. Methodology

The proposed solar powered desiccant air conditioning system's schematic diagram is shown in Fig.3. The working fluid is a desiccant liquid (preferably Calcium Chloride solution) which provides cooling and dehumidification to the air. The mechanism of the system requires further explanations. The system is driven by a force generated by the temperature difference between a water surface and the working fluid surface in contact with an air flow. The temperature of the water surface nearly corresponds to the wet-bulb temperature of the air while the desiccant surface's temperature corresponds to a comparatively high temperature. The temperature difference between the concentrated desiccant equilibrium temperature and the wet-bulb temperature is approximately 15-20°F. The system efficiently utilizes a comparatively weak desiccant to ensure cooling. A total of three counter flow heat exchangers are used in the system to transfer thermal energy from the air that enters the system from the outside to the exhaust air. From the top, the first heat exchanger causes evaporation of water into exhaust air. The second heat exchanger (liquid to liquid) that cools the water by exchanging heat with the desiccant solution. The third heat exchanger is direct contact type that works between the incoming outside air and the chilled desiccant solution resulting in the dehumidification of the air. A flat plate solar collector utilizes solar thermal energy to banish the water from the solution which increases its concentration. The concentrated desiccant solution also plays the role of a storage medium in case of the scarcity of sunlight (night hours and cloudy weather). The concentrated solution is further stored in a container for continuous supply. An external source of water is also introduced to the system for the continuous circulation of water. The proposed system consists of the heat-exchangers and internal piping systems made out of plastic materials which can be modified and improvised for obtaining a relatively higher rate of heat transfer. An external source of electrical energy can be implemented and adjunct to the flat plate solar collector to ensure continuous cooling.

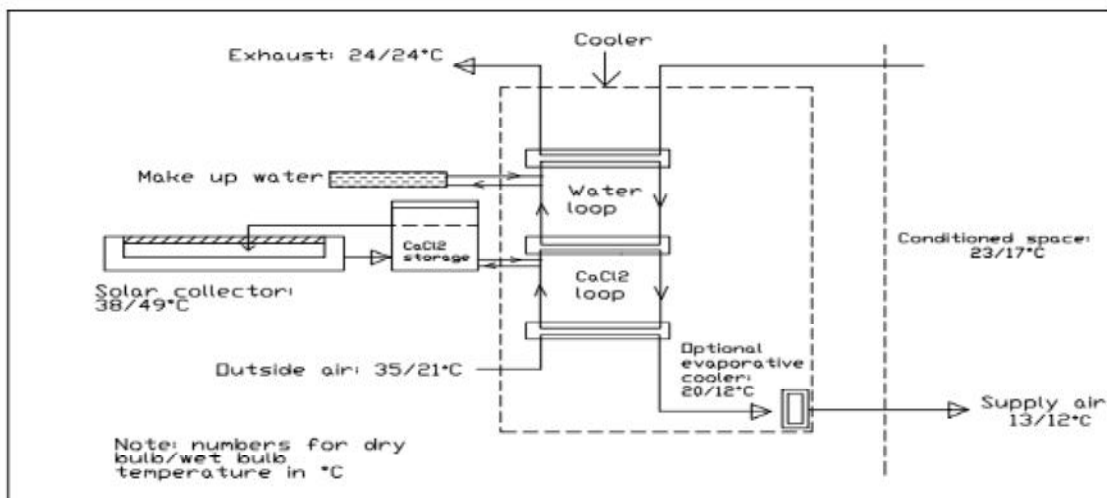

Fig. 3. Method of solar air cooling.

## 6. Desiccants

A desiccant may be defined as a dehumidifying substance which can remove water vapor or moisture from the air. Desiccants can come in solid or liquid states depending on its use. Normally, compressed air is passed over a desiccant to dry the air. They are regenerative type so they are recyclable. Some common desiccants' properties are discussed below:

### Silica gel

SiO<sub>2</sub> is commonly known as silica gel. It comes in round shaped little components of solid state. Pure silica gel is a rare type of desiccant which can be kept near food.

### Indicating silica gel

Indicating silica gel is a mixture of silica gel and cobalt chloride. The CoCl<sub>2</sub> will change its color from blue to light pink when it is saturated with water. For this "sign" it is called indicating silica gel. As CoCl<sub>2</sub> is a heavy metal salt, it is not safe to keep it near food.

### Calcium chloride

CaCl<sub>2</sub> is a vastly available desiccant material which comes both in solid powder and liquid solution form. It has corrosive properties over metal object. As a result, it has to be kept in plastic or glass jar.

### Calcium oxide and calcium sulfate

CaO and CaSO<sub>4</sub> are commonly known as quicklime and gypsum respectively. They are alkaline and erosive in nature so special precautions are necessary for handling them.

### Sodium chloride

Pure NaCl and its solution can be used as a desiccant. It is highly available in nature as well as in market. But it becomes saturated very fast in the presence of little water vapor.

**Table 1.** Desiccants and their price analysis

Desiccants	Price (tk.) per kg
Silica gel	2000
Indicating silica gel	2500
Calcium chloride	120
Calcium oxide	120
Calcium sulfate	125
Sodium chloride	70

## 7. Construction costing

The costs of the various components of required for the system are enlisted below. The list has been prepared after proper market analysis and certainty of the availability.

**Table 2.** Construction costing of solar air cooling system.

Quantity	Units	Cost per unit (tk.)	Total cost (tk.)
Liquid-air heat exchanger	2	850	1700
Liquid-liquid heat exchanger	1	550	550
Collector	1	850	850
Storage (water)	1	110	110
CaCl <sub>2</sub> (kg)	3	120	360
Fan	2	300	600
Pump	1	1050	1050
Piping, connections, construction			1800
Overhead			250
Glass plate (ft <sup>2</sup> )	3	30	90
		Grand total	7360

## Market analysis of conventional air conditioners

The price and cooling capacity analysis of some of the air conditioners which are available in the market are given below:

**Table 2.** Price and cooling capacity of conventional air conditioners

Brand	Size	Price(tk.)	Cooling capacity(kW)
Sample no. 1	0.75 ton	31500	2.5-2.6
Sample no. 2	1 ton	36000	3.4-3.5
Sample no. 3	1 ton	40000	3.5-3.6
Sample no. 4	1.5 ton	48200	5.1-5.5
Sample no. 5	1.5 ton	55000	5.2-5.4
Sample no. 6	2 ton	57600	6.3-6.6
Sample no. 7	2 ton	65000	6.9-7.0

## 8. Limitations

In case of cloudy weather and during night hours the system can't work properly if there is no external source of energy provided. The desiccant properties of CaCl<sub>2</sub> has some limitations at 25° C as it shows some crystallization property at a concentration around 50%. In dry conditions CaCl<sub>2</sub> is unable to dehumidify because of the absence of moisture. Scale formation may occur due to the excess use of CaCl<sub>2</sub>. The working process is comparatively slow due to less moving parts. Efficiency is relatively lower due to the non-uniform solar thermal radiation and the properties of CaCl<sub>2</sub>.

## 9. Application

Desiccant technology now-a-days has become the most effective intermittent solution for the industry to ensure space -conditioning .It is more effective than vapor compression and absorption system .We can use this system for the conditioning of a large area. This system utilizes solar energy which is free from the detrimental effects on the environment. The low cost of the system plays a role in it's widespread application in developing countries like Bangladesh.

## 10. Conclusion

As per the proposed plan of the project we have successfully analyzed the mechanism, effectiveness and construction cost of the air conditioner operating on solar radiation and produces cooling effect based on the dehumidifying property of the calcium chloride desiccant. The conclusions observed are: It dehumidifies the atmospheric humid air present in our surroundings successfully, provides cooling effect by absorbing the heat of air and it is cost effective as the whole cost of the project comes around Tk. 7360.00 only which is inexpensive compared to the conventional air conditioning units.

## 11. References

- [1] R.S. Khurmi and J.K. Gupta, "A Textbook of Thermal Engineering", chapter-35, article-35.3, p.752, 2007.
- [2] G.H. Hundy, "New Refrigeration and Air Conditioning", 2013.
- [3] <http://www.bryair.com/article/common-desiccants-and-their-properties-69> . Retrieved on 2015-07-15
- [4] <https://en.wikipedia.org/wiki/Desiccant> . Retrieved on 2015-06-12



## Feedstock to Oil Energy Conversion Efficiency in Pyrolysis of Organic Wastes: An Up to Date Review

M.S. Hossain<sup>1</sup>, M.R. Islam<sup>1</sup>, N.N. Mustafi<sup>1</sup>, H. Haniu<sup>2</sup>

<sup>1</sup>Department of Mechanical Engineering, Rajshahi University of Engineering & Technology,  
Bangladesh

<sup>2</sup>Department of Mechanical Engineering, Kitami Institute of Technology, Kitami City,  
Hokkaido 090-8507, Japan  
E-mail: samim\_ppi@yahoo.com

### Abstract

*The present study provides an up to date review of previous efforts in recent years for oil and liquids production from the pyrolysis of waste tires, plastics, biomass and co-pyrolysis of mixture organic wastes. There is growing interest in pyrolysis as a technology to treat these organic wastes to produce valuable oil, char and gas products. The most common reactors used are fixed-bed (batch), screw kiln, rotary kiln, vacuum and fluidised-bed. The key influence on the product yield, and gas and oil composition, is the type of reactor used which in turn determines the temperature and feedstock to oil energy conversion efficiency (FOECE). The FOECE of processes resulting from various operating conditions under which pyrolysis of organic wastes is carried out are reviewed. In addition to reactor conditions such as temperature and heating rates, other aspects of the organic waste pyrolysis such as catalyst type and their effects on oil yields are also reviewed. Pyrolytic oil characteristics such as heating value, sulfur content and density are summarized. The review revealed that the FOECE of a pyrolysis unit and product oil characteristic depends on the type of organic wastes pyrolyzed and the operating conditions of the pyrolysis processes.*

**Keyword:** FOECE, organic wastes pyrolysis review.

### 1. Introduction

The major components of urban wastes are plastic materials, variety of biomass originated refuses and different categories of tire rubber. Plastic, biomass and tires wastes presently pose difficulties when addressing their final post use destination. The main alternatives employed today are incineration and landfill deposition. However, these are far from optimal treatment options, because they can raise environmental issues, like toxic and greenhouse gas emissions, leachates, etc., besides wasting their organic content that could be otherwise valuable in several applications. On the other hand, steady depletion of fossil fuel and increased energy demand, motivated the researchers and technologists to search and develop different energy sources. Waste to energy has been a significant way to utilize the waste sustainably, simultaneously add to meet the energy demand. One of the promising ways of taking profit of the energetic and organic value of these wastes is pyrolysis. Pyrolysis have been gaining increasing attention of the researcher for the last four decades over the world. A lot of researches already have been completed ranging from laboratory to commercial scale.

The main options used for treating waste tires are through the use of tires as fuel in cement kilns, other energy recovery options for tires include use in power plants and co-incineration with other wastes, tires are used in material recovery options through the production of rubberised flooring in sports fields and playgrounds, paving blocks, roofing materials, etc. A significant proportion of the waste tires are used in civil engineering applications such as road and rail foundations and embankments re-treaded. There has been great interest in alternative treatment processes for waste tires, amongst which is the use of pyrolysis technology [1, 2]. Pyrolysis is the thermal degradation of the organic components of the tires, at typical pyrolysis temperatures of 500°C to produce an oil, gas and char product in addition to the recovery of the steel. The oil may be used directly as a fuel, added to petroleum refinery stocks, upgraded using catalysts to a premium grade fuel or used as a chemical feedstock. The gases from tire pyrolysis are typically composed of C<sub>1</sub>-C<sub>4</sub> hydrocarbons and hydrogen with a high calorific value, of sufficient energy content to act as fuel to provide the heat for the pyrolysis process. The solid char consists of the carbon black filler and also char produced during the pyrolysis of the rubber. It may be used as a solid fuel, as carbon black or upgraded to produce an activated carbon.

Plastics have become an indispensable ingredient of human life. They are non-biodegradable polymers of mostly containing carbon, hydrogen, and few other elements such as chlorine, nitrogen etc. Rapid growth of the world population led to increased demand of commodity plastics. Polyethylene (PE), polypropylene (PP) and

polystyrene (PS) are major plastic components of municipal solid waste (MSW). High density polyethylene is one of the largest used commodity plastics due to its vast applications in many fields. Due to its non biodegradability and low life, plastic contributes significantly to the problem of Municipal Waste Management. To avert environment pollution of plastic wastes, they must be recycled and recovered. Plastics being petrochemical origin have inherently high calorific value. Thus they can be converted back to useful energy. Many researches have been carried out to convert the waste plastics into liquid fuel by thermal and catalytic pyrolysis and this has led to establishment of a number of successful firms converting waste plastics to liquid fuels [3].

Fast pyrolysis has been proven to be an adequate process to produce a liquid product from woody materials, with suitable fuel properties (bio-oil), in contrast to the typical slow pyrolysis method of carbonization to produce char. However, some properties of this bio-oil restrict its direct use in a diesel engine, so research is still undergoing to improve these properties (bio-oil upgrading) [4].

In general, plastic waste pyrolysis allows the production of higher liquid products yields than those obtained with tires pyrolysis. Therefore, some authors [5] studied the pyrolysis of mixtures of plastics and tires wastes and observed that the use of plastic wastes favored tires pyrolysis and allowed increasing liquid yields, whilst higher contents of tires wastes favored the formation of solid compounds.

In general most urban wastes are a mixture of variety of waste components, which adds to the complexity of their treatment separately and also add additional cost in waste to energy recovery processes. It would be easier and cost effective if the waste mix would be converted into energy together.

The main product from the pyrolysis of organic waste mix is liquid. A pyrolysis unit of high liquid yield product with high energy density, engine useable, environmental friendly are the major challenges of the present scientists. The feedstock to oil energy conversion efficiency (FOECE) is one of the performance indicators for evaluation of successful techniques. Feedstock-to-oil energy conversion efficiency (FOECE) is defined as the ratio of pyrolysis oil energy to the total energy of the feedstock, which is calculated using Eq. (1).

$$\text{Conversion efficiency (FOECE), } \eta = \frac{Q_o \times W_o}{Q_R \times W_R + Q_P \times W_P + Q_B \times W_B} \times 100\% \quad \dots \dots \dots (1)$$

Where  $Q_R$ ,  $Q_P$ ,  $Q_B$  and  $Q_O$  represent the heating values of rubber, plastics, biomass and product oil;  $W_R$ ,  $W_P$ , and  $W_B$ ;  $W_O$  are the mass fractions of the rubber, plastics, biomass and product oil, respectively.

In this paper, the pyrolysis of organic wastes is reviewed in terms of the range of pyrolysis reactors used. The influence of process parameters, on the yield and FOECE from the pyrolysis of different organic wastes are discussed. The various liquid products from the pyrolysis of organic wastes are discussed in terms of their respective production conditions, their composition, characteristics, and the potential applications. The research related to producing higher value products from the organic waste pyrolysis process is also reviewed.

## 2. Pyrolysis of different organic solid wastes

### 2.1. Pyrolysis of tire waste

Yuwapornpanit and Jitkarnka [6] studied with metal-loaded zeolites and found that those are potential catalysts for upgrading the quality and quantity of waste tire pyrolysis products. The effect of Cu-support interaction on tire-derived oils, petrochemicals, and sulfur removal was studied by them using three types of zeolites (HBETA, HY and HMOR) as supports at a 5 wt% Cu loading. Catalytic pyrolysis of waste tire was operated in a bench reactor, and GC×GC-TOF/MS and SIMDIST-GC instruments were used to analyze the liquid products for chemical compositions and petroleum fractions, respectively. Sulfur in the pyrolysis products was determined by using an S-analyzer, whereas the gas composition was analyzed by using a GC-FID. As a result, all Cu-promoted catalysts can reduce more sulfur content in oils than their pure zeolites; therefore, Cu was found to enhance desulfurization of oils by converting sulfur compounds into thermodynamically stable forms on Cu. Furthermore, Cu-support interaction highly affected the sulfur removal from oils. They observed that benzene and ethylbenzene are common petrochemicals highly produced by the Cu-loaded catalysts.

Hita et al. [7] studied scrap tire pyrolysis oil (STPO) in order to remove undesired sulfur, nitrogen and unsaturated compounds while improving the properties of its different fractions (naphtha, diesel and gasoil) toward being used as a potential blend in the refinery. The studied catalysts are NiMo supported on 5 porous materials:  $\gamma$ -Al<sub>2</sub>O<sub>3</sub> (ALM catalyst), SiO<sub>2</sub>-Al<sub>2</sub>O<sub>3</sub> (ASA), SBA-15 (SBA), MCM-41 (MCM) and an equilibrated FCC catalyst (FCC). The hydrotreating runs have been carried out in a fixed bed reactor at 275–375 °C and 65 bar. A preliminary catalyst screening with a model mixture of representative STPO compounds has been performed for selecting the most active catalysts: ALM, ASA and MCM catalysts ensured the 99.9% removal of sulfur. Secondly and in the hydrotreating of STPO, our results point the suitability of ASA catalyst for obtaining the highest proportion of naphtha (25 wt%) and diesel (57 wt%).

Aydın and İlkilic [8] investigated the pyrolysis of waste tyres, with steel and fabric removed, in a 1.15 l capacity fixed bed reactor in nitrogen over the temperature range of 400–700 °C. They found that the oil yield increased from 31 wt.% at 400 °C, increasing to 40 wt.% at 500 °C, with little change in yield at higher

temperatures. There was a consequent increase in gas yield. They also investigated the influence of nitrogen flow rate on product yield and found only negligible differences in yield.

Islam et al., [9] using a fixed bed reactor pyrolysed 750 gm batches of waste tire and also found a high oil yield of 55 wt.% at 475 °C pyrolysis temperature with a corresponding char and gas yield of 36 wt.% and 9 wt.%, respectively.

Banar et al. [10] reported that for pyrolysis of tire derived fuel (steel removed) the maximum oil yield was only 38.8 wt.%, with char yield at 34 wt.% and a high gas yield of 27.2 wt.% for a heating rate of 5 °C min<sup>-1</sup> at a pyrolysis temperature of 400 °C

Kar [11] pyrolysed 10 gm batches of waste tires in a fixed bed, nitrogen purged reactor at 10 °C min<sup>-1</sup> heating rate. The influence of pyrolysis temperature from 375 to 500 °C was investigated and it was reported that the maximum oil yield of 60 wt.% oil was obtained at 425 °C. At the higher temperature of pyrolysis, of 500 °C, the oil yield decreased to 54.12 wt.%. The gas yield increased from 2.99 to 20.22 wt.% and char yield decreased from 50.67 to 26.41 wt.% as the temperature of pyrolysis was increased from 375 to 500 °C. Product yields from the pyrolysis of tire wastes with feed stock to oil energy conversion efficiency on the basis of reactor types are presented in Table 1.

Table 1. Product yield from the pyrolysis of tire wastes with feed stock to oil energy conversion efficiency

Study Nos.	Reactor type	Temp. (°C)	Product yield distribution			Oil characteristics			FOECE (%)
			Oil (wt.%)	Char (wt.%)	Gas (wt.%)	GCV (MJ/kg)	Sulfur (wt.%)	Density (kg/m <sup>3</sup> )	
Study -1 [8]	Fixed bed, batch	500	40.26	47.9	11.9	44.8	0.91	945	47.16
Study -2 [9]	Fixed bed, batch, internal fire tubes	475	55.0	36.0	9.0	39.13	-	-	64.43
Study -3 [10]	Fixed bed, batch	400	38.8	34.0	27.2	42.66	0.11	833	45.45
Study -4 [11]	Fixed bed, batch	425	60.0	30.0	10.0	42.70	1.46	992	84.03
Study -5 [12]	Fixed-bed, fire-tube heating	475	46.0	43.0	11.0	40.80	1.36	970	65.28
Study -6 [13]	Rotary kiln	500	45.1	41.3	13.6	41.70	1.54	962	56.31
Study -7 [14]	Fixed bed, batch	950	20.9	40.7	23.9	42.00	1.50	910	28.78
Study -8 [15]	Fixed bed, batch	500	42.0	47.0	11.0	39.12	-	-	49.20
Study -9 [16]	Vacuum, conical spouted bed	500	60.0	34.0	4.0	39.13	-	-	70.29
Study -10 [17]	Fluidised bed	750	31.9	38.0	28.5	40.32	-	-	37.37
Study -11 [18]	Conical spouted bed	500	62.0	35.0	3.0	40.05	-	-	72.63
Study -12 [19]	Vacuum	550	47.1	36.9	16.0	38.65	-	-	55.17

## 2.2. Pyrolysis of plastic waste

Several authors have studied plastics pyrolysis and have demonstrated the potentialities of this technology to process plastic wastes:

Lopez et al. [20] upgraded of chlorinated oils coming from the pyrolysis of plastic waste, in order to use them as fuel or feedstock for refineries. Two different samples of pyrolysis oils have been thermally and catalytically cracked in a 300 mL autoclave at 325 °C and the auto-generated pressure. They reported that thermal cracking converts the plastic pyrolysis heavy oils into light liquid fractions which are only composed of alkanes and aromatics. These light fractions present a very low quantity of chlorine compared to the initial oils and resemble gasoline and diesel-like products. Besides, a gaseous fraction rich in methane and with very high heating value is also produced, together with a fuel-like viscous product which remains in the autoclave. The relative proportions of each of these three fractions depend on the nature of the initial oils. Red Mud has proved to be a dehydrochlorination and cracking catalyst, since it gives rise to higher quantity of gases and light liquid fractions with a very low chlorine content (< 0.1 wt.%). Therefore, dechlorinated light oils can be obtained by Red Mud low temperature catalytic cracking of plastic derived chlorinated pyrolysis oils.

Hartulistiyoso et al. [21] investigated the temperature distribution in the reactor of a plastics pyrolysis process from waste bottles of beverage to produce fuel. The experiment was conducted using a cylindrical reactor, which has dimension of 0.31 m in diameter and 1 m high. The reactor was used to process 1500 gm plastics. They reported that to increase temperature from the ambient temperature to 450°C, 72 minutes of time were needed. The lowest temperature of 310°C was measured at the top of the reactor, whereas different temperature in the middle of the reactor was found to be 46°C respectively. The pyrolysis process of 1500 gm plastics was completed in 110 minutes to produce 21 g of fuel. They concluded that the pyrolysis process of plastics can produce fuel at 450°C in the reactor and 75°C outside the reactor.

Muhammad et al. [22] pyrolyzed plastic waste collected from waste electrical and electronic equipment (WEEE) in the presence of zeolite catalysts to produce a gasoline range aromatic oil. They used two zeolite catalysts; Y zeolite and ZSM-5. They reported that the quantity of oil produced from uncatalysed pyrolysis of plastics was more than 80 wt%. The gases consisted of hydrogen, methane and C<sub>2</sub>-C<sub>4</sub> hydrocarbons. When the zeolite catalysts were introduced there was a decrease of between 5 and 10 wt% in oil yield and a corresponding increase in gas yield. The composition of the oils derived from the uncatalysed pyrolysis of WEEE plastics were mainly aromatic with high concentrations of styrene. Addition of the zeolite ZSM-5 and Y zeolite to the pyrolysis process resulted in significant concentrations of benzene, toluene and ethylbenzene in the product oil but reduced concentrations of styrene. The oils from both thermal and catalysed pyrolysis also contained significant concentrations of polycyclic aromatic hydrocarbons for example, naphthalene, phenanthrene and pyrene.

Kumar and Singh [23] used response surface methodology (RSM) to optimize the process for catalytic pyrolysis of waste high-density polyethylene to liquid fuel over modified catalyst. The reaction temperature, acidity of the modified catalysts and mass ratio between modified catalysts to waste high-density polyethylene (HDPE) were chosen as independent variables. Face centered central composite (FCCD) design of experiment has been used. Optimum operating conditions of reaction temperature (450 °C), acidity of catalyst (0.341) and catalyst to waste HDPE ratio (1:4) were produced the maximum liquid product yield of 78.7wt%. They reported that the liquid fuel obtained by catalytic pyrolysis of waste HDPE at optimized condition consists of petroleum products range hydrocarbons (C<sub>10</sub>-C<sub>25</sub>) with high heating value (40.17 MJ/kg).

Syamsiro et al. [24] studied fuel oil production from municipal plastic wastes by sequential pyrolysis and catalytic reforming processes. Three kinds of municipal plastic wastes were collected from the final disposal site and the small recycling company in Yogyakarta city, Indonesia. Commercial Y-zeolite and natural zeolite catalysts were used in their study. They reported that the feedstock types strongly affect the product yields and the quality of liquid and solid products. HDPE waste produced the highest liquid fraction. The catalyst presences reduced the liquid fraction and increased the gaseous fraction. Furthermore, municipal plastic wastes pyrolysis produced higher heating value solid products than those of biomass and low rank coal.

Pyrolysis of a mixture containing polyethylene (PE), polypropylene (PP) and polystyrene (PS) that are major plastic components of MSW in different blends, studied by Kaminsky et al. [25]. They found that total conversion in all tests was higher than 80%, the main product being liquid (at normal conditions of temperature and pressure) with yields around 75wt% and gas yields were always lower than 10%, though products yields depended on the nature of plastic input. Product yields from the pyrolysis of plastic wastes with feed stock to oil energy conversion efficiency on the basis of reactor types are presented in Table 2.

Table 2. Product yield from the pyrolysis of plastic wastes with feed stock to oil energy conversion efficiency

Study Nos.	Reactor type	Feed type	Temp. (°C)	Product yield distribution			Oil characteristics			FOECE (%)
				Oil (wt.%)	Char (wt.%)	Gas (wt.%)	GCV (MJ/kg)	Sulfur (wt.%)	Density (kg/m <sup>3</sup> )	
Study -1 [22]	Catalytic	Plastic	420	61.00	-	-	43.00	-	854	136.1
Study -2[22]	Catalytic	HIPS	450	84.00	6	10	44.89	-	-	187.42
Study -3 [22]	Catalytic	RP	450	82.00	8	10	44.98	-	-	182.95
Study -4 [22]	Catalytic	ABS	450	66.50	-	-	44.50	-	-	146.79
Study -5 [23]	Catalytic	HDPE	450	78.70	-	-	40.17	-	864	100.27
Study -6 [24]	Two stage batch	HDPE	450	56.00	8	36	42.82		799	87.74
Study -7 [24]	Two stage batch	PE Bag	450	50.00	10	40	46.67	0.01	858	74.00
Study -8 [26]	Catalytic	Plastic	400	75.00	15	10	44.00			163.69
Study -9 [27]	Autoclave	Plastic	270	70.00	-	-	45.00	<0.002	793	156.25
Study -10 [28]	Hydrocracking	LDPE	450	30.64	68.27	1.10	46.00	-	-	69.91
Study -11 [29]	Semi batch fluidized	PVC	380	12.17	-	-	46.00	-	-	27.77

### 2.3. Pyrolysis of woody biomass waste

Lu et al. [30] investigated the catalytic performance of acidic ionic liquids (AIL) containing HSO<sub>4</sub><sup>-</sup> anion and acidic-functionalized imidazolium cations for biomass liquefaction was firstly investigated in polyethylene glycol 400-glycerol mixture at atmospheric pressure in order to explore green and efficient ways to convert woody biomass into sustainable energy and chemicals. They reported that fir sawdust (10 g) was up to 99% liquefied using 60 g of solvent at a concentration of 1-(3-sulfopropyl)-3-methylimidazolium hydrogensulfate ionic liquid of 0.3 mol·L<sup>-1</sup>, at a temperature of 423 K, in 60 min. The introduction of the sulfoalkyl substituent into the imidazolium cation of AILs was found to significantly improve their catalytic activity. The catalytic

performances of 1-(3-sulfopropyl)-3-methylimidazolium hydrogensulfate and 1-(4-sulfobutyl)-3-methylimidazolium hydrogensulfate are thus similar to that of H<sub>2</sub>SO<sub>4</sub> due to their double acidic sites. More than 90 wt% of the bio-oil was the heavy oil that derives from lignin.

Veses et al. [31] produced of upgraded bio-oils by catalytic pyrolysis of wood biomass in an auger reactor using low cost materials as catalysts. These materials included several clay minerals (sepiolite, bentonite and attapulgite) and an industrial waste from alumina production, known as red mud. They studied the influence of temperature (400–500 °C) and the effect of catalyst to biomass ratio (3:1–1:6, in weight) were also analysed. They reported that a temperature of 450 °C and the lowest catalyst proportion (1:6, in weight) were selected as the most appropriate to aim the pyrolysis for bio-oil production. The catalysts improved the characteristics of the obtained bio-oil as fuel (viscosity, acidity, oxygen content and calorific value). For every catalyst, the viscosity of the organic liquid fraction decreased (up to 34% in case of bentonite) while lower heating value increased (up to 20% in red mud tests). Concerning acidity, sepiolite and red mud produced a decrease in the total acid number (around 29% and 23%, respectively).

Kim et al. [32] studied fast pyrolysis of yellow poplar wood subjected to HDO (hydrodeoxygenation) for the purpose of reducing water content as well as increasing heating value. HDO was performed in an autoclave reactor at three different reaction factors: temperature (250–370 °C), reaction time (40–120 min), and Pd/C catalyst loading (0–6 wt%) under hydrogen atmosphere. After completion of HDO, gas, char, and two immiscible liquid products (light oil and heavy oil) were obtained. They reported that liquid products were less acidic and contained less water than crude bio-oil. Water content of heavy oil was ranged between 0.4 wt% and 1.9 wt%. Heating values of heavy oil were estimated between 28.7 and 37.4 MJ/kg, which was about twice higher than that of crude bio-oil. They observed that heavy oil had a lower O/C ratio (0.17–0.36) than crude bio-oil (0.71). H/C ratio of heavy oil decreased from 1.50 to 1.32 with an increase of temperature from 250 °C to 350 °C, respectively.

Zhu et al. [33] studied techno-economic analysis (TEA) to evaluate the feasibility of developing a commercial large-scale woody biomass HTL and upgrading plant. In this system, woody biomass at 2000 dry metric ton/day was assumed to be converted to bio-oil via HTL and further upgraded to produce liquid fuel. They evaluated: a state-of-technology (SOT) case with HTL experimental testing results underpinning the major design basis and a goal case considering future improvements for a commercial plant with mature technologies. They obtained the annual production rate for the final hydrocarbon product was estimated to be 42.9 and 69.9 million gallon gasoline-equivalent (GGE) for the SOT and goal cases, respectively. The minimum fuel selling price (MFSP) was estimated to be \$4.44/GGE for the SOT case and \$2.52/GGE for the goal case. Product yields from the pyrolysis of biomass wastes with feed stock to oil energy conversion efficiency on the basis of reactor types are presented in Table 3.

Table 3. Product yield from the pyrolysis of biomass wastes with feed stock to oil energy conversion efficiency

Study Nos.	Reactor type	Feed type	Temp (°C)	Product yield distribution			Oil characteristics			FOECE (%)
				Oil (wt.%)	Char (wt.%)	Gas (wt.%)	GCV (MJ/kg)	Sulfur (wt%)	Density (kg/m <sup>3</sup> )	
Study -1 [31]	Auger reactor	Wood	450	48	-	-	26.80	<0.10	1195	89.76
Study -2 [32]	Autoclave	Wood	450	50	-	-	37.40	-	-	86.25
Study -3 [33]	Hydrotreating	Wood	355	40	-	-	27.00	-	-	70.00
Study -4 [34]	Fixed bed	Nut shell	500	55	35	10	19.34	0.02	900	67.32
Study -5 [34]	Fixed bed	Rice husk	450	40	46	14	20.43	-	960	49.61
Study -6 [34]	Fixed bed	Jute stick	425	50	39	11	21.09	-	1224	64.03
Study -7 [34]	Fixed bed	Sawdust	440	41	-	-	19.08	-	910	47.41
Study -8 [34]	Fixed bed	Wheat straw	500	53	-	-	17.23	-	1099	60.48
Study -9 [34]	Fixed bed	Linseed residue	400	30	-	-	33.35	-	1095	60.64
Study -10 [35]	Fluidized bed	Seed scrops	500	35	49	16	40.60	0.10	-	49.51
Study -11 [36]	Fluidized bed	Rice straw	450	40	45	15	18.34	0.30	-	49.67
Study -12 [37]	Fixed bed	Coconut shell	550	43	26	31	38.6	Nil	1090	79.49

## 2.4. Co-pyrolysis of organic wastes

Li et al. [38] investigated of co-pyrolysis of discarded rubber and plastics in a tube furnace. They observed that compared with the pyrolysis of rubber or plastics separately, the co-pyrolysis of rubber and plastics produced a higher oil yield with a higher oil heating value. When the mass fraction of the rubber was 60 wt%, the pyrolysis

## A complete off-grid PV-Diesel-Battery Hybrid Energy System with feasibility analysis, system modeling and Optimization

SK. A. Shezan<sup>1</sup>, A. Hossain<sup>2</sup>, A. Ishrak<sup>3</sup>

<sup>1</sup>Department of Mechanical Engineering, Faculty of Engineering, University of Malaya, 50603, Kuala Lumpur, Malaysia.

Email: shezan.ict@gmail.com

<sup>2</sup>Department of Nuclear Science and Engineering, Military Institute of Science and Technology, Mirpur, Dhaka, Bangladesh.

Email: altab76@gmail.com

<sup>3</sup>Department of Economics, Brac University, Mohakhali, Dhaka, Bangladesh.

Email: ishrak010@yahoo.com

### Abstract

*The electrification process of the remote areas and decentralized areas are being a vital fact for the improvement of its agricultural and industrial issues such as the southern region of Malaysia. Renewable energy resources can be used extensively to support and fulfill the demand of expected loads of these areas. This article presents an analysis of a complete off-grid PV-Diesel-Battery Hybrid renewable energy model with a backup of a 5kW generator. The main objective of the present analysis is to visualize the optimum volume of systems capable of fulfilling the requirements of 38 kWh/d primary load in coupled with 5 kW peak for 37 households for a decentralized area of the said region. The lowest cost of energy (COE) is nearing USD 0.895/kWh and Net Present Cost (NPC) is USD 158,206. The decrement of the CO<sub>2</sub> emissions also can be identified from the simulation results by using that most feasible renewable energy system.*

**Keywords:** Renewable Energy, Photovoltaic, HOMER, Optimization, Hybrid Model.

Nomenclature	Subscripts
A Net Area of solar module (m <sup>2</sup> )	Gen-1 Generator 1
E Electrical energy (kWh)	Gen-2 Generator 2
H yearly standard global solar radiation	PV photovoltaic
rSolar module ratio (%)	NREL National Renewable Energy Laboratory
v Wind speed (m/s)	HOMER Hybrid Optimization Model for Electric Renewable

### 1. Introduction

The development along with technological advancement of a country is completely dependent on the energy stored by that country. Fossil fuels are still the main resources of energy to handle the energy demand of the world[1]. But, the problem has been arising during last few decades for having not only the negative impacts of fossil fuel on environment but also the shortage of it. Therefore, some serious efforts should be taken to find out some alternatives before ending the resources of the fossil fuels where renewable energy draws the most attention to the current researchers of the world [2]. The renewable energy resources vary with other conventional fossil fuel resources in such a way that they have some characteristics like renewability, inexhaustibility, naturally replenished and sometimes cost-effective. The main resources of renewable energy are solar (PV and thermal), wind, hydropower, biomass, tidal, wave and geothermal etc. This study has chosen the PV as one of the energy resource components of the proposed hybrid system suitable for off-grid residential power supply[3]. It is a common phenomenon in tourist sector that the stand-alone diesel generators are usually used to supply the electricity rather than grid connections. Therefore, the study only concerns the energy supply by RES installation which can be categorized into following two groups:

- i. Hybrid Renewable Energy system: This type of system consists of a RES system with conventional fossil fuel systems (especially with diesel generators). For example, PV hybrids, WECS hybrids and small to

large scale PV/WECS hybrids etc[4].

- ii. Autonomous Controlled system: It is a complete independent system which produces the energy by stand-alone and/or with a combination of other renewable energy technology such as photovoltaic (PV) only, wind energy conversion system (WECS) only and combined PV-WECS.

Therefore, the energy consumption phenomenon of tourist sectors cannot be represented by the studies of energy efficiency of industrial and domestic sectors. The literature shows very few (only two) case studies for the feasibility of RES in tourist accommodation. For this analysis, HOMER has been used for simulation and therefore estimation of various output parameters by providing some input parameters for a specific area such as the southern region of Malaysia Hence the current study focuses on the following points below:

- i. To discuss the feasibility of the proposed system considering the efficient power distribution and proper maintenance of RES.
- ii. To estimate the most economically feasible technology for RES and compare it with other technologies. Here, the comparison is made considering the NPC and COE for various RES.

For the last few years the visiting rate of Malaysia has been increased rapidly. Another great demand for the household activities has been increased dramatically [5]. The increasing power consumption, increasing energy generation costs, bad weather and climate conditions have increased the interest in the renewable energy system. The low carbon emissions are one of the reasons for increasing demand of renewable energy system[6].

## 2. Methodology

### 2.1 Location analysis and Data Resources

The daily solar radiation data have been collected for every month of the year 2009 from the Malaysian meteorological department for the Southern region of Malaysia. An estimation of solar insolation on horizontal surface has been done by using well known Angstrom Correlation and the sunshine hour data of Southern region, Malaysian Meteorological Department, the nearest meteorological station from Selangor, Malaysia[7]. Fig. 1 shows the geographical position of Southern Region (Lat.: 2° 44' N, Long.: 101° 42' E). To calculate wind resources data, Malaysian Meteorological Department has measured wind speed for the year 2009 by maintaining the height of 30 m upwards from the ground surface level. The result was not up to the expectation level that is why just the wind and solar resource and average temperature data have been considered to discover the most efficient hybrid renewable energy system. HOMER runs few to thousands hours to simulate the best suitable energy system considering the optimum power supply and load demand.

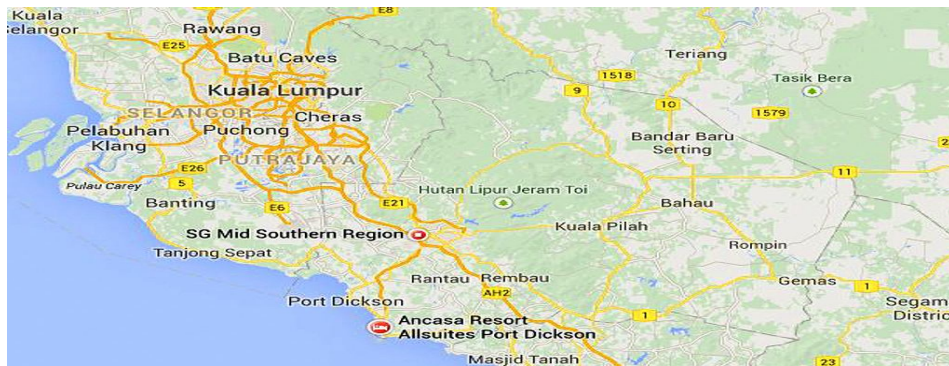

Fig. 1: Southern Region of Malaysia [8].

### 2.2 Hybrid Renewable Energy System Components

#### 2.2.1 Solar Energy (Photovoltaic) System

Monthly average global radiation data has been taken from Malaysian Meteorological Department[9]. From the longitude and latitude data of the considered area can be calculated the clearness index through HOMER renewable energy software. The synthesized 2304 hourly values for a year can be created by HOMER renewable energy software through the utilization of the Graham algorithm. The solar radiation is elevated in April, February, March, August, September and October has been represented in Fig. 2. USD 50 /kW have been considered as the rate of PV component counting the mechanism for Malaysia. The life span of the system has been preferred as 2 decades.



There are 3 types of module has been considered for PV modules such as 3 kW, 4 kW and 5 kW. Table 1 shows the factors of PV module related with the simulation.

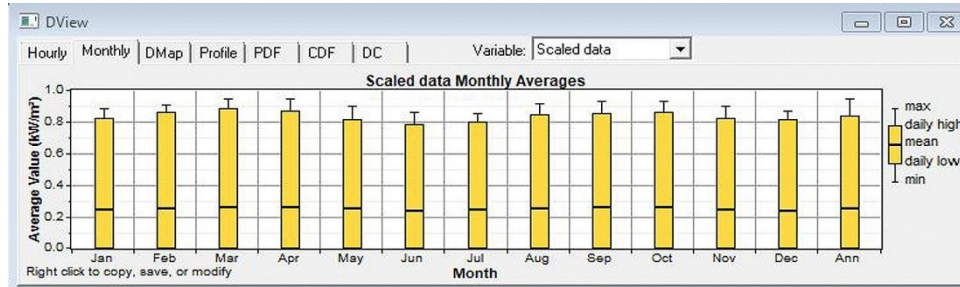

Fig. 2: Monthly average solar radiation data in a specific year.

Table 1: Photovoltaic array expense assumption and procedural factors.

Factors	Value
Net Cost	50 \$/kW
Substitution Cost	40 \$/kW
Maintenance and Operation Cost	5 \$/kW
life span	20 Years
Derating factor	80 %
Tracking System	No Tracking System

### 2.2.2 Specification of Diesel Generator module

The fuel used in HOMER is modeled by a linear curve characterized by a slope and intercept at no load. Table 2 shows the assumptions of cost for a diesel generator and the other factor related with power generation and range of capacity. Fig.3 shows the cost curve generated by the diesel prices in terms of cost analysis.

Table 2: Procedural parameters with Cost conjecture for Diesel Generators.

Factors	Value
Net Cost	120 \$/kW
Substitution Cost	100 \$/kW
Maintenance and Operation expense	0.014 (5 kW) \$/kW
Lifetime	900000 Minutes (15,000 Hours)
Least Load quotient	30 %
Fuel Curve Slope	0.441/h/kW <sub>output</sub>
Fuel Curve Intercept	0.062/h/kW <sub>rated</sub>
Fuel Cost	0.8 \$/liter

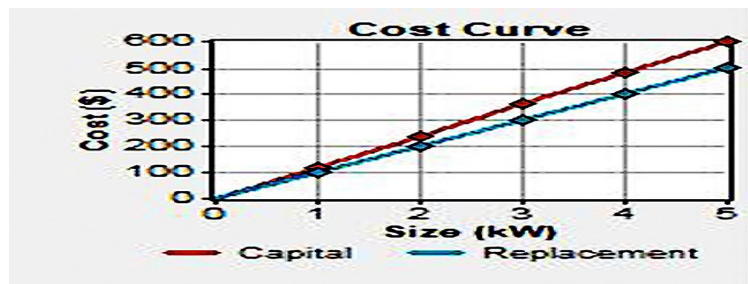

Fig. 3: Cost Curve of Diesel Generator.

### 2.2.3 Battery Module

In that off-grid hybrid renewable energy system, the Hoppecke 60PzS 300 storage batteries have been utilized. There are six stipulations such as effectiveness, life time, rectifier effectiveness, rectifier aptitude;



substitution and net cost have been shown in Table 3. Fig.4 shows the cost curve indicated the cost analysis for the battery module.

**Table 3:** Procedural Parameters with Cost Assumptions for Battery.

Parameters	Value
Lifetime	1 decade
effectiveness	95 %
Rectifier aptitude	90 %
Rectifier effectiveness	89 %
principal Cost	90 \$/kW
substitution Cost	70 \$/kW

### 2.2.5

#### Converter Specification

The converter is one kind of device that can convert electrical power from ac to dc in a process called rectification and from dc to ac in a process called inversion. There are two types of converters such as rotary (rectifier or inverter) and solid-state can be sampled by Homer renewable energy software. The verdict variable refers to the converter size that delegate to the inverter capacity; by inverting dc power with the device can generate the utmost amount of ac power. We used a 3 kW Converter for our hybrid System. The life time is 20 years and the efficiency for inverter and rectifier as follows 90 % and 85 % respectively. The cost analysis with converter has been represented by the cost curve mentioned by Fig. 5.

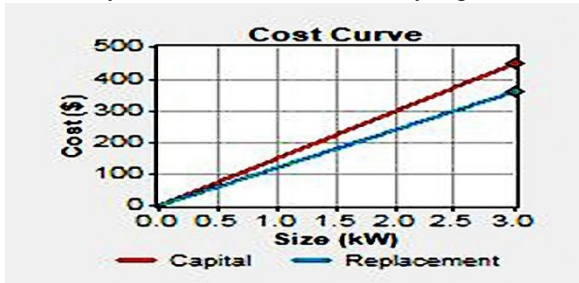

**Fig.5:** Cost Curve of Converter.



**Fig. 4:** Cost curve for Battery Module

### 3. A Developed off-grid Hybrid Renewable Energy System

Solar energy (Photovoltaic) and Battery module have been used with a diesel generator and a converter module in this analysis. An extra generator has been used as a back-up energy producer. An electrical primary load demand, renewable energy resources such as solar resource and other mechanisms as like as PV (photovoltaic) array, battery storage, and converters constitute an off-grid hybrid renewable energy system. Fig. 6 shows the model of a complete hybrid renewable energy system.

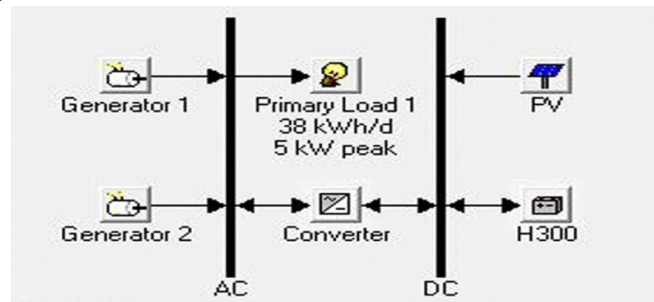

**Fig.6:** Complete Block Diagram of a PV-Diesel Hybrid Energy System.

Deciding on the load is one of the most important steps in the design of the proposed hybrid systems. In this study, a hypothetical model community of 37 families in 37 households, each comprising of 4 family members, is considered. The household in the rural area is simple and does not require large quantities of electrical energy for lighting and electrical appliances due to not being connected with the national grid network. A rural household generally uses electrical energy for lighting, cooling and entertaining[10]. There are 2 fans (Star standard ceiling fan, 50 W), 4 energy savings bulbs (Philips tornado bulb, 20 W each), 1 television (Sony bravia, 50 W), 2 table lamps (Emen 69076, 5 W) and 1 refrigerator (160 W) have been calculated for each family and considered for the load demand analysis. The primary load or energy consumption pattern usually varies over 24h and over different months of the year. Fig. 7 and 8 shows two load profiles on a day of Northeast Monsoon (January) and Southeast Monsoon

(July). HOMER simulates the operation of a system by making energy balance calculations for each of the 8760h in a year. Load demand data had been amalgamated through the specification of emblematic daily load demand profile data and after that some parameters has been added. Therefore, about 38kWh primary loads can be handled per day along with a scale of yearly 5kW peak load.

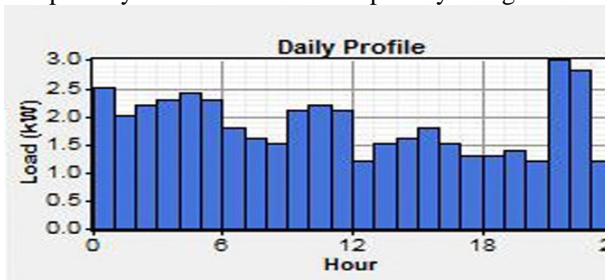

Fig.7: Daily load profile of a particular day of Northeast monsoon (January).

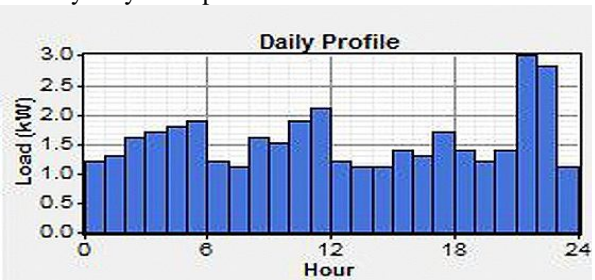

Fig.8: Daily load profile of a particular day of southwest monsoon (July).

#### 4. Simulation, Optimization Results and Discussion:

An optimal hybrid renewable energy system can be designed by HOMER renewable energy software through large number of hourly simulations again and again. Various values for wind speed, solar radiation, diesel cost and least renewable fraction have been contemplated to conduct simulations and these values assuring much more suppleness in the analysis. Fig. 9 shows Simulation outcomes in considering an off-grid hybrid pv-diesel-wind-battery hybrid energy model with an highest capacity shortage of 0.03%. USD has been considered as the currency for all costs related with that hybrid system. Fig. 10 shows the details calculation, simulation results and cost analysis with System architecture, NPC, COE, Operating cost, Electrical energy produced by wind turbine, PV, and diesel generator system, unmet load, excess electricity, capacity shortage and renewable fraction of the most monetarily practicable hybrid energy system relevant for the preferred area in both simple case and best case. In the same time, with a base NPC of USD 158,206 and base COE of USD 0.895/kWh, an off-grid hybrid PV, diesel generator and battery hybrid system is efficiently more feasible and this is observed by the sensitivity analysis in the most economically feasible case. Fig. 11 shows the electrical energy generated with practicability from the off-grid hybrid PV-diesel-wind-battery system. A hybrid energy system can be considered as a most feasible renewable energy system constituted of 5 kW PV module, a diesel generation with a divisional power of 5 kW (utilizing 5 kW) and 100 storage batteries in cementation to 3 kW converters and rectifiers.

Sensitivity Results		Optimization Results		Simulation Results																				
PV (kW)	Label (kW)	H300	Conv. (kW)	Initial Capital	Operating Cost (\$/yr)	Total NPC	COE (\$/kWh)	Ren. Freq.	Diesel (\$)	Label (hrs)	Label (hrs)	Batt. Lf. (\$/yr)												
25	2	100	3	\$ 20,940	4,058	\$ 72,820	0.412	0.93	1,007	994	12.3													
30	2	100	3	\$ 21,190	4,054	\$ 73,012	0.413	0.93	978	979	12.4													
20	2	100	3	\$ 20,590	4,098	\$ 73,982	0.413	0.92	1,071	1,013	12.3													
30	3	100	3	\$ 20,810	4,127	\$ 73,567	0.416	0.90	1,383	893	12.7													
25	3	100	3	\$ 21,060	4,112	\$ 73,621	0.416	0.90	1,343	886	12.7													
30	3	100	3	\$ 21,310	4,096	\$ 73,667	0.417	0.91	1,302	875	12.8													
20	3	200	3	\$ 29,810	3,543	\$ 75,105	0.425	0.95	623	641	20.0													
20	4	100	3	\$ 20,930	4,258	\$ 75,359	0.426	0.89	1,512	812	12.9													
25	4	100	3	\$ 21,180	4,248	\$ 75,490	0.427	0.89	1,478	808	12.9													
25	3	200	3	\$ 30,050	3,557	\$ 75,529	0.427	0.96	609	640	20.0													
30	4	100	3	\$ 21,430	4,261	\$ 75,896	0.429	0.89	1,465	805	13.0													
30	3	200	3	\$ 30,310	3,584	\$ 76,126	0.430	0.96	609	640	20.0													
20	2	200	3	\$ 29,690	3,649	\$ 76,335	0.432	0.97	463	647	20.0													
20	5	100	3	\$ 21,050	4,335	\$ 76,472	0.432	0.89	1,588	760	13.0													
25	2	200	3	\$ 29,940	3,660	\$ 76,725	0.434	0.97	447	645	20.0													
25	5	100	3	\$ 21,300	4,338	\$ 76,751	0.434	0.89	1,566	757	13.1													
30	5	100	3	\$ 21,550	4,348	\$ 77,138	0.436	0.89	1,551	753	13.1													
30	2	200	3	\$ 30,190	3,686	\$ 77,310	0.437	0.97	446	645	20.0													
20	4	200	3	\$ 29,930	3,726	\$ 77,563	0.439	0.94	797	639	20.0													
25	4	200	3	\$ 30,180	3,748	\$ 78,091	0.442	0.94	791	639	20.0													
30	4	200	3	\$ 30,430	3,772	\$ 78,650	0.445	0.94	788	639	20.0													
25	5	200	3	\$ 30,050	3,925	\$ 80,221	0.454	0.93	986	639	20.0													
25	5	200	3	\$ 30,300	3,945	\$ 80,732	0.457	0.93	979	639	20.0													
30	5	200	3	\$ 30,550	3,972	\$ 81,328	0.460	0.93	979	639	20.0													
20	1	2	200	3	\$ 29,810	5,922	\$ 105,510	0.597	0.96	3,003	886	451	20.0											
20	1	4	100	3	\$ 21,050	6,629	\$ 105,796	0.598	0.89	3,888	882	587	12.8											
25	1	4	100	3	\$ 21,300	6,616	\$ 105,870	0.599	0.90	3,849	882	583	12.9											
25	1	2	200	3	\$ 30,060	5,931	\$ 105,877	0.599	0.96	2,985	886	448	20.0											
20	1	3	100	3	\$ 20,930	6,663	\$ 106,105	0.600	0.90	3,923	884	665	12.8											
30	1	4	100	3	\$ 21,550	6,616	\$ 106,123	0.600	0.90	3,824	882	578	12.9											
25	1	3	100	3	\$ 21,180	6,624	\$ 106,148	0.601	0.90	3,824	882	578	12.9											

Fig. 9: Simulation Results of a complete PV-Diesel-Battery Hybrid Renewable Energy System

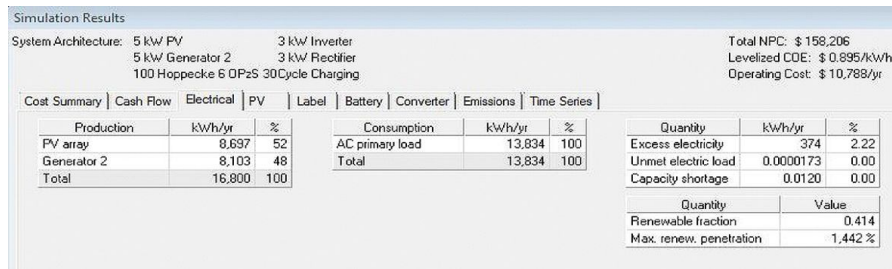

Fig. 10: Simulation Results with the power generation, NPC and COE.

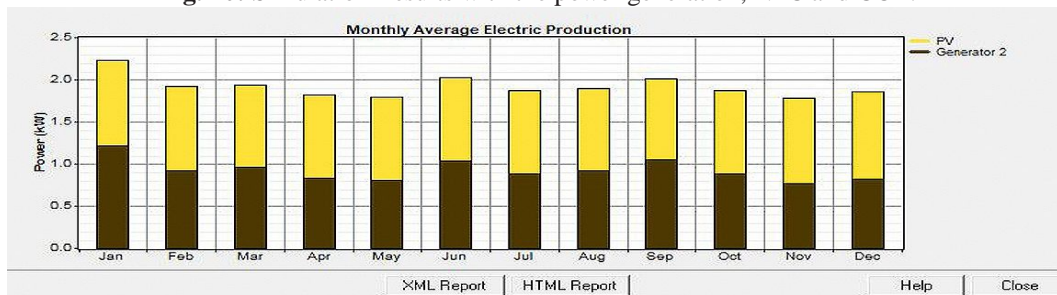

Fig.11: Power generation with generator 2 coupled with PV module.

## 5. Conclusion

With the consideration of the demand of huge amount of electrical power a complete hybrid PV-diesel-battery renewable energy model has been developed. This hybrid energy system will be applicable especially for decentralized and remote areas. Since, diesel based power generation system completely depends on fossil fuel which is too expensive, therefore, only diesel generator cannot be feasible to supply the electrical power to the remote areas. The simulation reveals that the selected location has a huge potentiality of solar radiation about 8.025–17.370 kWh/ m<sup>2</sup>/day which exhibits a promising feasibility to develop a PV-Diesel Generator-Battery hybrid energy system. For the economic feasibility analysis of the proposed system, it is found that for 37 decentralized off-grid households would be composed of 5 kW PV array together with a 5 kW diesel generator and 100 numbers of batteries of which each has a nominal voltage of 12 and capacity of 300 Ah. The investigation of the best results shows that the COE of the optimized system is USD 0.895/kWh and the NPC of the optimized system is USD 158,206. By establishing this energy system would lead to reduction in emissions of GHG and CO<sub>2</sub>. In the near future we will try to introduce some more convenient renewable energy model and proper control system for the hybrid energy system for the different area of the world.

## Acknowledgement:

This work has been carried out by the financial support of the HIR-MOHE project of University of Malaya. The project title is “Hybrid Solar Energy Research Suitable for Rural Electrification”. The project no is UM.C/HIR/MOHE/ENG/22.

## References:

- [1] Stigka, E.K., J.A. Paravantis, and G.K. Mihalakakou, *Social acceptance of renewable energy sources: A review of contingent valuation applications*. Renewable and Sustainable Energy Reviews, 2014. **32**: p. 100-106.
- [2] Moka, S., M. Pande, M. Rani, R. Gakhar, M. Sharma, J. Rani, and A.N. Bhaskarwar, *Alternative fuels: An overview of current trends and scope for future*. Renewable and Sustainable Energy Reviews, 2014. **32**: p. 697-712.
- [3] Ullah, K., R. Saidur, H. Ping, R. Akikur, and N. Shuvo, *A review of solar thermal refrigeration and cooling methods*. Renewable and Sustainable Energy Reviews, 2013. **24**: p. 499-513.
- [4] Bravo, Y., C. Monné, N. Bernal, M. Carvalho, F. Moreno, and M. Muñoz, *Hybridization of solar dish-stirling technology: Analysis and design*. Environmental Progress & Sustainable Energy, 2014.
- [5] Jain, A., P. Chalapathi Rao, P. Choudhury, R. Mehta, and S.K. Mittal, *Optimization studies for hybrid and storage designs for parabolic solar trough systems with the system advisor model*. Environmental Progress & Sustainable Energy, 2013. **32**(4): p. 1247-1254.
- [6] Shezan, S.K.A., R. Saidur, A. Hossain, W.T. Chong, and M.A. Kibria, *Performance Analysis of Solar-Wind-Diesel-Battery Hybrid Energy System for KLIA Sepang Station of Malaysia*. IOP Conference Series: Materials Science and Engineering, 2015. **88**(1): p. 012074.

- [7] Lee, S. and B. Pradhan, *Landslide hazard mapping at Selangor, Malaysia using frequency ratio and logistic regression models*. *Landslides*, 2007. **4**(1): p. 33-41.
- [8] Samat, N., *Characterizing the scale sensitivity of the cellular automata simulated urban growth: A case study of the Seberang Perai Region, Penang State, Malaysia*. *Computers, Environment and Urban Systems*, 2006. **30**(6): p. 905-920.
- [9] Zulkifli, N., N. Razali, M. Marsadek, and A. Ramasamy. *Probabilistic analysis of solar photovoltaic output based on historical data*. in *Power Engineering and Optimization Conference (PEOCO), 2014 IEEE 8th International*. 2014. IEEE.
- [10] Shezan, S.A., R. Saidur, K.R. Ullah, A. Hossain, W.T. Chong, and S. Julai, *Feasibility analysis of a hybrid off-grid wind-DG-battery energy system for the eco-tourism remote areas*. *Clean Technologies and Environmental Policy*, 2015. **17**(8): p. 2417-2430.

## Experimental Study of a Low Temperature Organic Rankine Cycle for Small Scale Power Generation

Md. Arafat Islam<sup>1</sup>, Ashfaq Ahmad Shoaib<sup>1</sup>, Mohammad Asaduzzaman Asif<sup>1</sup>, Mir Sakib Mustashin<sup>1</sup> and Tahmidur Rahman<sup>1</sup>

<sup>1</sup>Military Institute of Science and Technology

Dhaka-1216, Bangladesh

E-mail: ashfaqahmadshoaib@gmail.com

### Abstract

*The Rankine cycle (ORC) is an Ideal and mathematical model which is mainly used to prognosticate the efficiency of steam engines. It's a thermodynamic cycle of a heat engine that converts heat into mechanical work. In Organic Rankine Cycle, organic substances are used rather than water as a working fluid. Organic working fluids are better than water because of having more turbine efficiency due to higher mass flow rate and low temperature heat source can be used to operate the cycle. In this research an experimental setup was locally fabricated to justify the usability of Dichloromethane as a working fluid of ORC power plant. The turbine of this set up was capable of driving a DC generator and it was able to produce up to 10 volts and .09A current while continuously operating the ORC. This preliminary concept was taken to further analyze the properties of Dichloromethane as a working fluid of ORC power plant at various load conditions. Temperatures, pressures, mass flow rates, fuel consumptions, vapor generation rates, condensation rates etc. were measured. The plant runs at three different operating pressures of approximately 137, 206 and 275 Kpa. The plant had shown its best performance at the operating pressure of 40 psi using R-30 as a working fluid. Not only that, but for all operating pressure it was experimentally proven that, the efficiency of ORC plant is always higher than the conventional power plant.*

**Keywords:** ORC, organic working fluid - dichloromethane, inorganic working fluid - water, impulse turbine

### 1. Introduction

Many industrial processes produce waste heat that is typically rejected to lower temperature heat sinks. There are number of ways in which such waste heat can be recovered to produce useful energy. Recovery of waste heat offers the benefit of increasing overall efficiency in case of power generation or provides auxiliary power in other waste heat application. A standard Rankine cycle uses steam as a working fluid for primary power generation and it operates at relatively higher temperatures (523.15-873.15K) in order to maximize the Carnot efficiency. That's why low temperature heat sources are unsuitable for it. However Organic Rankine Cycle (ORC), which uses organic fluids rather than water and can operate at low temperatures to utilize the waste heat sources. It is the specialty of the organic fluids which can evaporate at low temperature and exert high pressure as compared to steam. That's why organic fluids make the cycle more efficient. But the main challenge is to condense the organic fluids. Here in this experiment dichloromethane was used as an organic fluid. The aim was to investigate ORC plant operating character compared to conventional steam turbine power plant.

### 2. Experimental Setup

#### Model A

An experimental setup was locally fabricated to justify the usability of Dichloromethane as a working fluid of ORC power plant. The turbine of this set up was capable of driving a DC generator and it was able to produce maximum 10 volts and .09A current while continuously operating the ORC. The plant was consisting of boiler, burner, turbine, DC generator and condenser. Figure 1 demonstrates the experimental set up of locally fabricated ORC plant.





**Fig. 1.**Experimental setup of Model A

**Model B**

The P7669T is a miniature steam turbine power plant consists of furnace, boiler, micro steam turbine, condenser, fluid storage tank and a control panel. It is a total closed loop system. Control panel consists of different measuring instruments like ammeter, voltmeter, vortex shading meters, temperature meter, pressure meter and load switch. The plant consists of total four bulbs as loads. The maximum load of each bulb is 0.8 watt. Therefore the total plant capacity is 3.2 W.



**Fig. 2.**Experimental setup of Model B

### 3. Experimental Result

**Table 1.** Turbine inlet temperatures at different pressures

Operating Pressure(KPa)	Turbine Inlet Temperature Steam Turbine Power Plant (K)Fluid H <sub>2</sub> O	Turbine Inlet Temperature ORC Power Plant (K)Fluid CH <sub>2</sub> Cl <sub>2</sub>
206	384.15	327.15
275	393.15	341.15

**Table 2.** Turbine exhausts temperatures at different pressures

Operating Pressure 206KPa				
For H <sub>2</sub> O				
Parameters	Load Conditions			
	Load 1	Load 2	Load 3	Load 4
Dynamometer Voltage (Volts)	6	4	2.5	1.5
Dynamometer Current (Amps)	0.03	0.06	0.07	0.085
Power (W)	0.18	0.24	0.175	0.1275
Generator Speed (rad/s)	363	224	175	140
For CH <sub>2</sub> Cl <sub>2</sub>				
Parameters	Load Conditions			
	Load 1	Load 2	Load 3	Load 4
Dynamometer Voltage (Volts)	6.5	4	3	1.5
Dynamometer Current (Amps)	0.03	0.06	0.08	0.09
Power (W)	0.195	0.24	0.18	0.135
Generator Speed (rad/s)	371	234	187	142
Operating Pressure 275KPa				
For H <sub>2</sub> O				
Parameters	Load Conditions			
	Load 1	Load 2	Load 3	Load 4
Dynamometer Voltage (Volts)	12	10	9	6
Dynamometer Current (Amps)	0.06	0.11	0.14	0.15
Power (W)	0.72	1.1	1.26	0.9
Generator Speed (rad/s)	911	735	545	361
For CH <sub>2</sub> Cl <sub>2</sub>				
Parameters	Load Conditions			
	Load 1	Load 2	Load 3	Load 4
Dynamometer Voltage (Volts)	12	11	9	7
Dynamometer Current (Amps)	0.06	0.11	0.14	0.17
Power (W)	0.72	1.21	1.26	1.19
Generator Speed (rad/s)	915	754	586	380

## **Water Heating and Drying using Solar Energy and Air-Con Waste Heat**

Zohra Begum Hameed Sharieff, MNA Hawlader, Sany Izan Ihsan  
Department of Mechanical Engineering,  
International Islamic University Malaysia, Jalan Gombak,  
53100 Kuala Lumpur, Malaysia.

### **Abstract**

In the tropical countries air-conditioning has become a necessity as the ambient temperature is found to be high. In Malaysia most of the apartments are air-conditioned, at least one room. Every KW of electricity which is consumed by the air-conditioner, about 4KW is thrown into the atmosphere. The energy available at the inlet of the condenser is about 80 degree Celsius and can be utilized for useful purposes. The waste heat from the air-conditioner is used for water heating and drying purposes. A water condenser is attached at the exit of the compressor which will absorb most of the superheat and latent heat. A dryer is connected at the exit of the air-condenser so that it can supply clean hot air for drying. Even a recovery of 60% of this waste energy can heat 200 liters of water up to 60 degree Celsius. This system reduces global warming and is quite efficient to be used for domestic and industrial purposes.

***Keywords:*** *Air conditioning, Waste heat recovery, Water heating, Drying, Solar Energy*

### **1. Introduction**

Air conditioning of buildings is essential for countries which are located in the tropical region, particularly those countries which are closer to equator, such as Malaysia and Singapore, where the daily average temperature can be as high as 27.8 degree Celsius [1, 2]. In Malaysia the residential sector is usually made up of 61% linked houses (62% are air-conditioned), 27% apartments (36% are air-conditioned) and 12% detached houses (more than 70% are air-conditioned) [3]. Most of these houses are in need of water heater and cloth dryer. The dissipated heat which is released from the condenser contributes to global warming and also in an effort to reduce the usage of the conventional energy resources, a system was developed to use renewable energy resources (both solar and ambient energy) and air con waste heat for low temperature application. Air-conditioning, water and air heating form an excellent combination, where the air con waste heat will be sufficiently utilized and the solar and the ambient heat can boost it up further depending on the requirements. An evaporator collector, instead of conventional solar liquid or air collector will be used because as it can collect more solar and ambient energy, and with regarding to this even the operating temperature of the evaporator collector will be much lower than the ambient temperature. The collectors will operate at high efficiency, as high as 80 to 85% as the heat losses from the evaporator collector will be very low. The efficiency of the conventional collector is about 60%.

### **2. The System**

The system is the integrated solar assisted heat pump system for water heating and drying. The system's schematic diagram is illustrated by Figure 1.



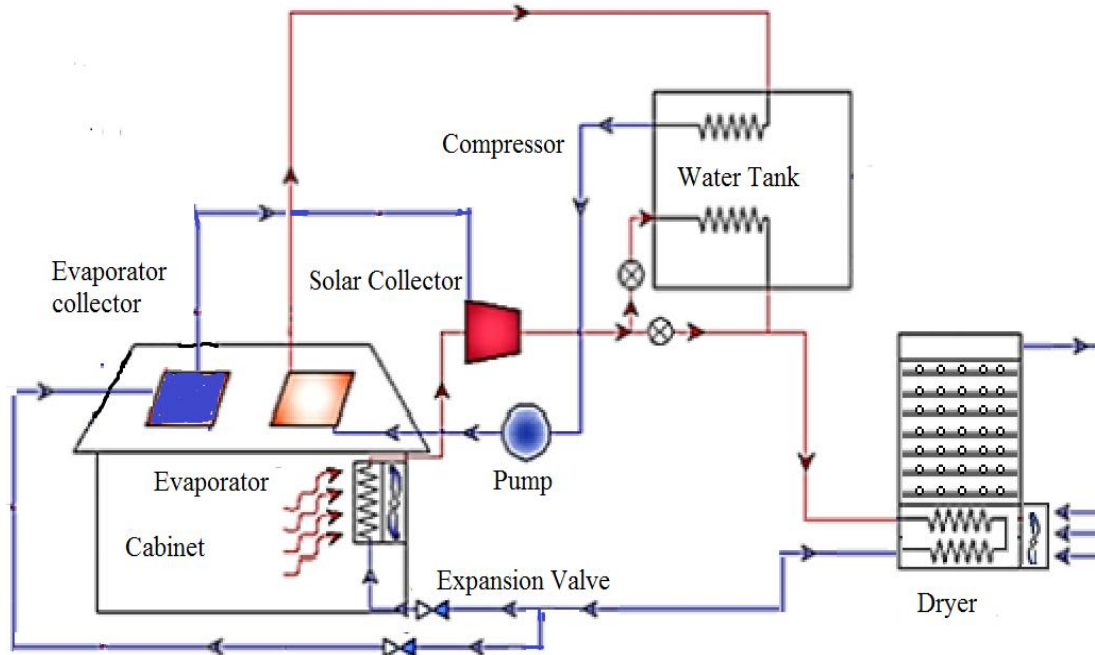

**Figure1:** Solar assisted heat pump system for water heating and drying

In this system, refrigerant will enter the compressor as saturated or slightly superheated vapor at a lower pressure of the overall cycle. At the compressor, due to energy input, pressure is raised to a higher level and the refrigerant will become superheated. Gradually, the refrigerant will pass through the condenser, where it will reject heat and it will ideally become saturated or slightly sub-cooled liquid. The refrigerant will then be throttled in an expansion valve to an evaporator maintained at a lower pressure of the cycle. The low quality two phase mixtures of the refrigerant in the evaporator will absorb the heat from the surroundings before it will enter the compressor and the cycle will be repeated.

The refrigerant flow path of the system will include the compressor, evaporator, solar evaporator collector, solar water collector, water cooled condenser, air cooled condenser and the expansion valves. The two evaporators will be connected in parallel, whereas the two condensers will be connected in series. After complete condensation, liquid refrigerant will split into two ways. Each of them will expand into a flow regulating device, thermostatic expansion valve, reaching the evaporator in the room and the evaporator collector which is located outside for the collection of the solar and ambient energy.

In the solar evaporator-collector, the two phase refrigerant will flow through the serpentine copper tubes which is brazed underneath the absorber plate. It is heated by incident solar radiation and the energy will be absorbed from the ambient air through an absorber plate. The refrigerant super heat level at the evaporator-collector outlet will also be automatically controlled by the thermostatic expansion valve.

Then the refrigerants, which will be arriving from the solar evaporator collector and the room evaporator, will be mixed together and will enter the suction side of the compressor. At this point of the cycle, electrical/mechanical energy will be added to the refrigerant to increase its temperature and the pressure. The high pressure and temperature refrigerant vapor from the compressor outlet will first enter the coil which is immersed in the water of the condenser tank and then passes through the air-cooled condenser. The heat of condensation from the superheated refrigerant vapor is recovered both in air and water-cooled condensers, which otherwise would have been wasted in the normal circumstances. The saturated/sub-cooled liquid refrigerant will split into two paths and will enter the evaporator in the room and the outdoor solar evaporator collector, and the cycle repeats.

### 3. Analytical Model

The system includes: compressor, Condenser (air condenser and water condenser), expansion valve, solar water collector, evaporator/ room and dryer.

#### 3.1 Air/ Water Condenser

In the air and water cooled condensers the, heat transfer was evaluated by the following equations [5]:

$$Q_r = m_r (h_2 - h_1) \quad (1)$$

where,

$m_r$  = mass flow rate of refrigerant, kg/s

$h_1$  = enthalpy of refrigerant at the inlet to the condenser, kJ/kg

$h_2$  = enthalpy of refrigerant at the outlet to the condenser, kJ/kg

$$\text{Effectiveness of the condenser, } \epsilon_{\text{cond}} = 1 - \exp(-\text{NTU}) \quad (2)$$

where NTU (number of thermal units) of condenser is given by

$$\text{NTU} = (\text{UA})_{\text{cond}} / (\text{mc}_p)_{\text{min}} \quad (3)$$

The temperature variation inside the water storage tank is described by:

$$(\text{Mc}_p) \frac{dT_s}{dt} = Q_C - Q_L - Q_{\text{loss}} \quad (4)$$

where,

$M$  = Mass of water in store

$Q_C$  = heat received by the condenser

$Q_L$  = Energy withdrawal from store to support load

$Q_{\text{loss}}$  = Heat losses from the store

#### 3.2 Drying Rate

The variation of moisture content of the drying rate is given by the following equation [6]:

$$\frac{dM}{dt} = -k(M - M_e) \quad (5)$$

where,

$M$  = product moisture content

$M_e$  = equilibrium moisture content

$t$  = time

The drying constant,  $k$ , is expressed by the Arrhenius equation [7]

$$k = d \exp(-f/T) \quad (8)$$

#### 3.3 Compressor Work

To drive the reciprocating compressor, the work input required is given by the following equation:

$$W_c = P_1 V_1 m_r \left( \frac{n}{n-1} \right) \left[ \left( \frac{P_2}{P_1} \right)^{\frac{n-1}{n}} - 1 \right] \quad (9)$$

where,

$P_1$  and  $P_2$  are compressor suction and discharge pressure;

$V_1$  corresponding suction volume and  $m_r$  represents refrigerant mass.

### 3.4 Evaporator Room

The room evaporator usually serves a dual purpose in making the room comfortable for use. Firstly, it brings down the room temperature to a cool and comfortable condition, and secondly, it removes humidity from the room. This means that a combined heat and mass transfer, where both sensible and latent heat transfer, takes place in the direct expansion coil of the room evaporator.

The rate of sensible heat removal from the room is based on the temperature difference as follows:

$$dq_s = h_c A_{evap,r} (T_a - T_{sur}) \quad 10$$

The rate of latent heat removal from the room is based on the rate of condensation, which is based humidity ratio difference as follows:

$$dq_l = \dot{m}_w h_{fg} \quad 11$$

Where the rate of condensation is

$$\dot{m}_w = h_D A_{evap,r} (\omega_a - \omega_{sur}) \quad 12$$

And  $h_D$ , which is the mass convection coefficient, is approximated for water vapour as : □

$$h_D = \frac{h_c}{C_{p,m}} \quad 13$$

The total heat gain by the evaporator is the sum of the sensible and latent heat, which is calculated as

$$dq_t = dq_s + dq_l = \frac{h_c A_{evap,r}}{C_{p,m}} (h_a - h_{sur}) \quad 14$$

The heat gain from the refrigerant is determined from the enthalpy difference of the refrigerant as follows:

$$Q_r = \dot{m}_{r,room} (h_{outlet} - h_{inlet}) \quad 15$$

Assuming negligible losses, the energy balance for the air condenser is

$$\dot{m}_{r,room} (h_{outlet} - h_{inlet}) = \frac{h_c A_{evap,r}}{C_{p,m}} (h_a - h_{sur}) \quad 16$$

### 3.5 Expansion Valve

Both evaporator and evaporator/collector are fitted with individual thermostatic expansion valves. The thermostatic expansion valve is responsible for maintaining constant degree of superheat at the evaporator outlet. For the modelling of the expansion valve isenthalpic expansion process is assumed.

The expansion process is assumed to be isenthalpic, therefore

$$h_{f,i} = h_{f,o} \quad 17$$

Assuming the capacity of the expansion valve is large enough, the mass flow rate shall be calculated using:

$$M_r = (PD)N \eta_v / V_a \quad 18$$

### 3.6 Solar water collector

The liquid solar collector used to preheat the feed water has a single glazing, with an aluminium plate as the absorber. The collector is of parallel tube-type, with seven riser tubes positioned in parallel with the collector's length.

The useful energy absorbed by the water, in terms of its inlet and outlet temperature is expressed as:

$$Q_u = \dot{m}_w c_{p,w} (T_{w,out} - T_{w,in}) \quad 19$$

The useful energy delivered from the collector to the water can be expressed through the Hottel-Willier equation :

$$Q_u = F_R A_c [I(\tau\alpha) - U_L(T_{in} - T_a)] \quad 20$$

Overall heat loss coefficient,  $U_L$ , of the collector is a function of the top, bottom, and edge losses.

$$U_L = U_T + U_B \quad 21$$

The top loss coefficient,  $U_T$ , can be expressed as:

$$U_T = \left\{ \frac{N}{\frac{C}{T_p} \left[ \frac{T_p - T_a}{(N+f)} \right]^e} + \frac{1}{h_w} \right\}^{-1} + \frac{\sigma(T_p + T_a)(T_p^2 + T_a^2)}{(\varepsilon_p + 0.00591Nh_w)^{-1} + \frac{2N+f-1+0.133\varepsilon_p}{\varepsilon_g} - N} \quad 22$$

Where  $N$  is the number of glass covers. Several other correlations were simplified to fit the equation (4.107). These are:

$$f = (1 + 0.089h_w - 0.1166h_w\varepsilon_p)(1 + 0.07866N) \quad 23$$

$$e = 0.43(1 - 100/T_p) \quad 24$$

$$C = 520(1 - 0.000051\beta^2) \quad 25$$

For  $0^\circ < \beta < 70^\circ$ . For  $70^\circ < \beta < 90^\circ$ , use  $\beta = 70^\circ$

The bottom loss coefficient,  $U_B$ , is defined as:

$$U_B = \frac{k}{t} \quad 26$$

With  $k$  is the thermal conductivity of the insulation material, and  $t$  is the insulation's thickness.

The collector heat removal factor,  $F_R$ , is a quantity that relates actual useful energy gain of a collector to the useful gain if the collector surface is at liquid inlet temperature.

$$F_R = \frac{\dot{m}c_p}{A_c U_L} (1 - e^{-(A_c U_L F' / \dot{m}c_p)}) \quad 27$$

With  $F'$  is the collector efficiency factor:

$$F' = \frac{\frac{1}{U_L}}{W \left[ \frac{1}{U_L [D_o + (W - D_o)F]} + \frac{1}{C_b} + \frac{1}{\pi D_i h_{f,i}} \right]} \quad 28$$

The fluid heat transfer coefficient, for single phase condition, is determined from Dittus-Boelter equation:

$$h_{f,i} = 0.83 \text{Re}^{0.8} \text{Pr}^{0.33} \frac{k_f}{D_i} \quad 29$$

And  $C_b$  is the bond conductivity:

$$C_b = \frac{k_b b}{\gamma} \quad 30$$

With  $k_b$  is the bond thermal conductivity,  $b$  is the bond's width, and  $\gamma$  is the bond average thickness.

The function  $F$  in the equation 28 is the standard efficiency and it is described as

$$F = \frac{\tanh[m(W - D_o)/2]}{m(W - D_o)/2} \quad 31$$

#### 4. Results and Discussion:

##### a) Water Heating

The experiment was conducted to heat the water inside the hot storage tank and seven different cases were conducted to heat the water. The case 1 consists of the air conditioner and water collector, case 2 consists of the water collector only, case 3 consists of the air-conditioner only, case 4 consists of the air-conditioner, water collector and the refrigerant collector, and the case 5 consists of the whole integrated system, case 6 consists of only refrigerant collector and case 7 consists of the water collector and the refrigerant collector. From the figures 2a and 2b we can see that the maximum water temperature achieved was 60.8 degree Celsius for case 5 which was



followed by case 2 followed by case 3, case 4, case 6, case 7 and finally case 1. It is seen that temperature of water for case 5 which consists of the whole integrated system is lower than the temperature of water achieved by case 7.

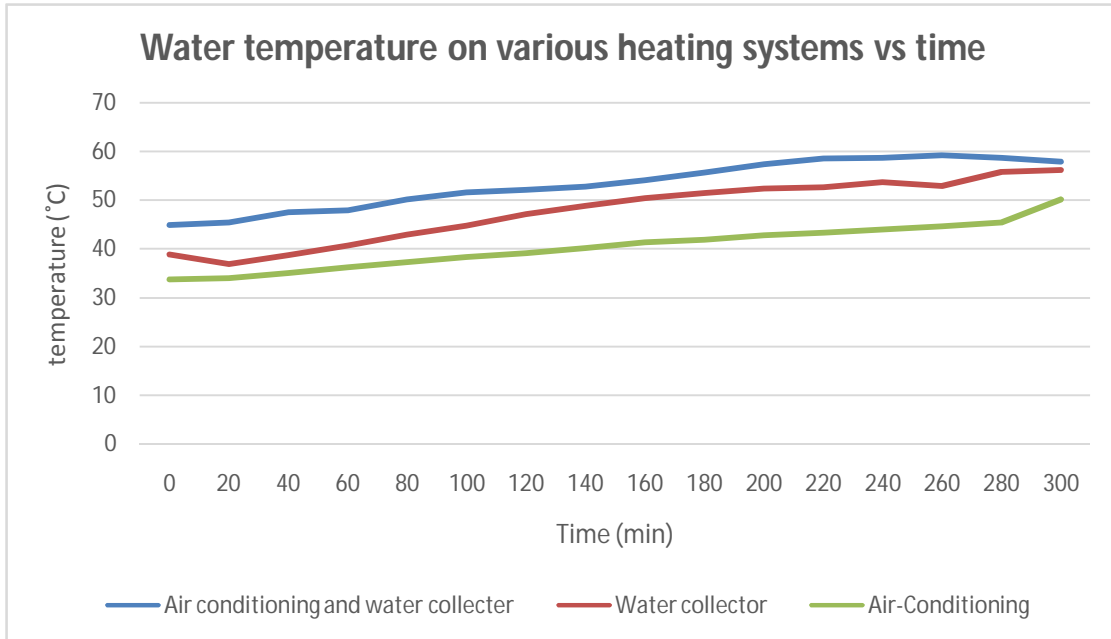

**Figure 2a:** General findings of water temperature at different experimental setup

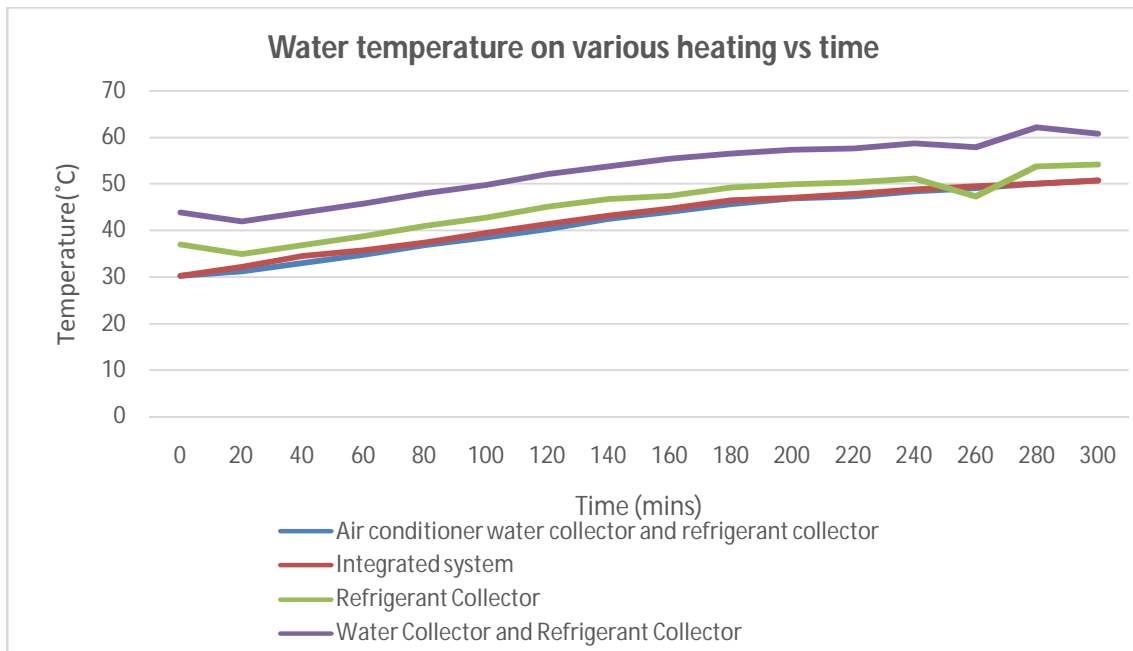

**Figure 2b:** General findings of water temperature at different experimental setup

## b) Drying

Different experiments were conducted for drying the cloth to measure the drying time which is required for the cloth to dry. The experiment was conducted for 5 hours. The initial weight of the cloth when dry was 95.5 g while the initial weight of the cloth when wet was found to be 300 g.

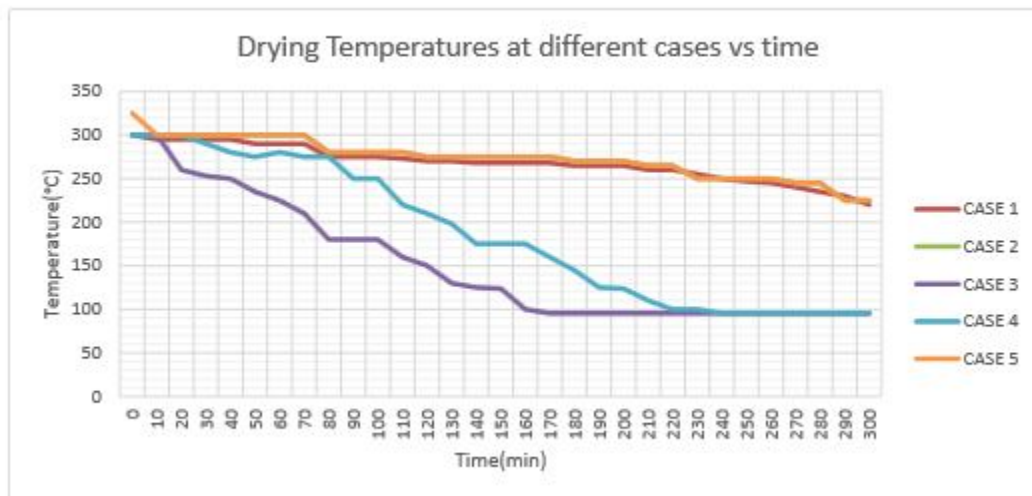

**Figure 3:** Drying time at different experimental setup

Different cases conducted for the drying of the cloth are as follows: Case 1 consists of the indoor drying, case 2 which consists of outdoor drying, case 3 which consists of air-conditioner with water heating, case 4 consists of air-conditioner with refrigerant panel and finally case 5 which consists of air-conditioner without water heating. Case 1 was done by placing the drying chamber inside the room without blowing the air towards the cloth and for case 2, the drying chamber was placed under the sun radiation for 5 hours. For case 3, case 4 and case 5, hot air is blown from the condenser fan into an air vent connected to the drying chamber. From Figure 3, we see that drying time for case 4 should have been lesser when compared to case 3, but the result was inversed. This was because the humidity of the ambient was little higher during the experiment for case 3 when compared to the humidity during the case 4. As the ambient becomes more humid the ambient temperature will be colder so the evaporating molecules in the wet cloth will be smaller. On contrary, the climate during the experiment for case 4 was cloudy and little rainy where the rain droplets fall on the cloth for every ten minute interval of time.

## 5. Conclusion:

This research has been developed to utilize the waste heat from the air-conditioner which can save the energy wasted from being thrown away to the environment. Air-conditioner rejects 4KW heat to the surroundings which is more than enough to provide thermal applications. Several experiments were done in different cases to observe the outcome of the system. The objective was claimed and this system is marketable especially in countries which are near the equator.

## 6. References:

- [1] Zain, Ahmed, 'Renewable energy, buildings and the fuel crisis'. Development in Renewable Energy and Sustainability, p13-24(2008).
- [2] Kubota, T., "Usage of air conditioners and windows in residential areas in Johor Bahru city". 7<sup>th</sup> International Seminar on Sustainable Environment and Architecture, 20-21 November 2006. Hasanudin University Makassar (2006).
- [3] Azni Zain-Ahmed, "Integrating sustainable energy in building: a case study". Proc FAU Conference, Copenhagen, Denmark, 14-15 May 2008, Copenhagen, Denmark (2008).
- [4] Hawlader, M N A and K.A. Jahangeer, "Solar heat pump drying and water heating in the Tropics". Solar Energy, 80: 492-499(2006).



[5] Hawlader, M N A. and Ye Shaochun, "Performance of a solar integrated heat pump air-conditioner, water heater and dryer". *Int Journal of Ambient Energy*, 29(4), 189-196(2008).

[6] Herbas, T.B., Berlincl, E.C., Urie, C.A.T, Marques, R.P, and Parise, J.A. R., "Steady-state simulation of vapour compression heat pumps." *International Journal of Energy Research*, 17, 801-816(1993).

## Electricity Generation from Poultry Waste in Bangladesh

Md. Wahiduzzaman Sajib<sup>1</sup>, Mehadi Hassan, S.M. Najmul Hoque, M. Mourshed  
Rajshahi University of Engineering & Technology (RUET), Rajshahi-6204, Bangladesh.

<sup>1</sup>E-mail: sajob122025@gmail.com

### Abstract

*Biogas is one of the most popular and effective renewable energy sources, which is produced by the decomposition process of organic materials under anaerobic condition. It can be used to run generator to produce electricity besides cooking, running pump for irrigation, incubator etc. This environmental friendly energy source can meet the lack of power of Bangladesh by generating huge electricity. The main purpose of this paper is to design a 50kw biogas plant from poultry waste in order to produce electricity to fulfill the power demand of the poultry farm as well as to supply electricity commercially the rural areas. 5 ton poultry waste, collected from 50000 chickens can produce 40-80 m<sup>3</sup>/hr gas. This gas can easily run a 50 KW biogas generator. The plant life is about 20 years and payback period is 5 years. We have also found Net Present Value (NPV) positive and internal rate of return is 19%.*

**Keywords:** *Biogas, poultry litter, electricity generation, technical and cost analysis.*

### 1. Introduction

Energy, one of the imperative needs of human being plays a key role for the socio-economic development of developing countries like Bangladesh. Energy consumption pattern of any country indicates the state of socio-economic development. Conventional energy (natural gas, oil, coal) is considered as the main energy source in the world. About 35% of world's primary energy consumption comes from natural gas. Recently, the production of fossil fuels has reached up to 79% compared to other energy sources [1]. This is a tremendous threat for the environment. Biomass is considered as the prominent source of renewable energy in Bangladesh as well as in the world. In the low income country like Bangladesh, rural households contribute the largest share of the biomass fuel consumption. Biomass energy is a potentially sustainable and relatively environment friendly source of energy. Biogas is produced from the organic materials from plants and animals such as straw, leaves, weeds, aquatic plants, human and animal excrement etc which may be degraded by various micro-bacteria in presence or absence of air. The decomposition under anaerobic process produces a flammable gas known as biogas. Cattle dung, kitchen waste, crop residue and most importantly poultry dropping are the most profound sources of biogas in Bangladesh. Biogas can be used for cooking as natural gas is used, running pump for irrigation, running metal to get luminous light( 0.75m<sup>3</sup> of biogas can light 7 biogas lamps for an hour ), running generator to produce electricity running motor vehicles, refrigeration running, running incubator etc. The residue of biogas is a very high quality organic fertilizer. It can be used for fish culture, mushroom culture, pearl culture, producing seeding from seed, Earth-worm culture for poultry and fish feed.

### 2. Present status of the biogas plant in Bangladesh

Different organization both government and nongovernment are involved in disseminating the biogas technology throughout the country. The total number of biogas plants in the country is about 250000. So far Bangladesh Council for Scientific and Industrial Research (BCSIR) has installed about 22000 biogas plants in the country. Besides, Local Government Engineering Department (LGED) has installed about 116711, Bangladesh Rural Advanced Committee has installed about 1200. Grameen Shakti (GS) has installed about 50012 and Department of Environment has installed about 260 biogas plants in the country. However, the number of biogas plants in the poultry sector is not significant. Out of the total number of biogas plants in the poultry sector BCSIR has installed about 3000 to 3500 biogas plants, whereas the number of biogas plants installed in poultry sector by LGED is 2014 [2].

### 3. Poultry litter

The poultry litter used in this work is distributed on the floor of sheds that serves for the birds. For this application it can be used various materials such as: wood shaving, peanut hulls, rice hulls, coffee hulls dry grass and chopped corn cobs. The increase of domestic chickens generates large amount of residues and so it becomes necessary to think about treatment alternatives and/or final destination for this, in order to minimize the impacts caused by it. 20% of global emissions of greenhouse gases come from agriculture activities, where the methane and nitrous oxide are the main gases involved. The average production of bed is 2.19 kg per chicken in natural form that means without separation of solids and including the humidity percentage. The quantities produced about the characteristics of poultry litter depend on the base material used, the creation time and bird population density. The litter has long been used as a food source for ruminants, however, due to health problems that occurred in Europe in 2001(as bovine spongiform encephalopathy), the Agriculture ministry of Brazil banning the use in the litter directed to ruminant feed [3].

### Chemical Composition

A density for poultry waste is to use as fertilizer. If applied corrected, it can produce effective result. However, if the application rate exceeds the retention capacity of the soil or the requirements of the crop, the fertilizer can produce concentration of elements at toxic levels to plants, affecting the water resource and leading to the forming of nitrites. The main component of pollutants from the waste of birds is nitrogen and phosphorus. One should take into account the possibility of disease transmission due to the fact that these wastes may contain pathogenic microorganisms. Table 1 presents data of the litter chemical composition, noting that the data refers to a bed of wood shavings after a creating cycle of the 60 days.

**Table 1.** Chemical composition of poultry litter

<b>Micronutrients and metals</b>	<b>µg/g</b>	<b>Macronutrients</b>	<b>µg/100g</b>
<b>Copper (Cu)</b>	303	Nitrogen (N)	2.08
<b>Iron (Fe)</b>	1,786	Phosphorus (P)	1.01
<b>Manganese (Mn)</b>	294	Potassium (K)	2.61
<b>Zinc (Zn)</b>	217	Calcium (Ca)	2.08
<b>Sodium (Na)</b>	2,629	Magnesium (Mg)	0.53
<b>Chromium (Cr)</b>	5	Sulfur (S)	0.028
<b>Lead (Pb)</b>	22		
<b>Nickel</b>	2		

### Alternative for Energy Generation

The remaining material in the process of rearing chickens can become a resource or a pollutant. For the environment impact become minimal, the litter must have proper management and use as best as possible. If not, they can pollute surface and groundwater, can also increase: mineral nutrients, organic substances that require oxygen, suspended matter and sometimes carry pathogenic microorganisms. The creation of chickens can also adversely affect air quality due to emissions of gases such as ammonia, breath odor, and dust production. One way to mitigate the environment impact produced in the production of boilers is to use the bed to produce anaerobic or biogas as fuel to generate electricity directly. The calorific value of the poultry litter depends on the humidity level, however, for air dried samples, this value is in the range of 9 to 13.5Mj/kg (about half the coal calorific value) [3].

## 4. Electricity generation

Electricity generation from poultry waste is relatively new in Bangladesh. Different types of technologies are being used in different poultry farms in the country. The most common one is to use natural gas generator which uses biogas as fuel. Most of the farms which are producing electricity from poultry waste do not have any hydrogen sulfide removal unit. Hydrogen sulfide is severely corrosive to all metals associated with the transportation of gas and metal parts of engine which are driven by such gas containing H<sub>2</sub>S. To overcome these problems associated with H<sub>2</sub>S, GTZ Bangladesh has installed a flagship project at Raj Poultry Farm in Faridpur district which is more scientific than any other technology being used currently [9]. Paragon Agro Ltd, a leading agro based company of Bangladesh, has started producing electricity from poultry waste. The farm that mainly does business in poultry, tea and horticulture, set up three plants to generate a total 475 kilowatts (KW) of electricity a year. Paragon started its first bio-electricity plant with a capacity of 50 KW in Gazipur in March last year. The other two plants went into operation in October in Gazipur and Mymensingh. The Gazipur plant has a capacity to generate 300 KW of electricity and the Mymensingh one has a capacity of 125 KW. The company will also make organic fertilizers using the slurry produced as a by-product in the biogas digester [4].

### Components of biogas unit

At first the waste are collected in the mixing chamber where the ratio of waste: water=1:2. Then with the help of a screw type pump it is send to the digester where the digestion process takes places. Then the gas produced is stored in the gas storage tank. Then the gas passes through a cooler hydrogen sulfide removing unit for purification. The purified gas goes to the biogas generator and then the mechanical energy converted into electrical energy and electricity produced. For maintaining the temperature inside the digester a hot water tank is provided and the over flow of the digester are collected in the holding tank.

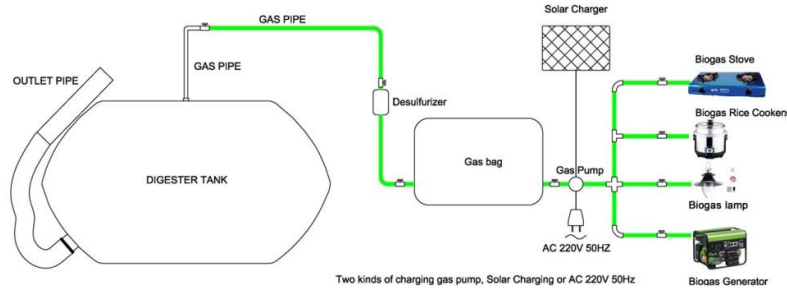

**Fig. 1.** Flow diagram of electricity generation from biogas (poultry waste)

### Size of biogas unit

The amount of manure fed into a digester each day has an important effect on its operation, this is measured by volume added in relation to the volume in the digester, but the actual quantity fed to the digester also depends on the temperature at which the digester is maintained. In order to determine the unit size of a biogas unit, the following mathematical equation must be achieved:

$$\text{Digester size (m}^3\text{)} = \text{Daily feed (m}^3 \text{ dai}^{-1}\text{)} * \text{Retention time (day)} \quad (1)$$

The digester size can be defined as the total size of the biogas unit, which includes the effective size of any volume occupied by the fermented material and the volume of gas storage. Size of the daily feed -in is the size of a mixture of waste with water added to the digester once daily or several times and the average concentration of total solids of 10%, where mixing the organic wastes with water depends on its water content. In the case of wet animal wastes, such as manure the production of mixing is 1:1. Generally, storage capacity has to be calculated by the average live weight of animals kept in husbandry systems, amount of added water, periods of no fertilization of crops and the animal species. In order to plan a biogas plant and to design a digester, several design parameters must be determined which are: ratio of gathered waste from manure canals to total waste, number of chickens in farm, amount of manure produced by a chicken which is usually 1.8 m<sup>3</sup> chicken-1 month-1, quantity of daily liquid organic matter deposition into the digester, hydraulic retention time, density and quantity of daily dry organic matter deposition into digester, and digester load which is usually 2-4 kg m<sup>-3</sup> day<sup>-1</sup>. the aforementioned design parameters are used to determine the total volume of the materials that are intended to be stored in the tank and are equal to the internal part of the tank (about 100%) is empty and the substrates should not fill it, because it is the place where the gas will accumulate. even in case of designing other storage tanks (e.g. liquid organic matter tank) it is required to leave 10% of the tank volume empty [5].

### Gas collection chamber

In this research a rectangular shaped box, one side of which is made of glass for visibility of the different conditions and the rest five sides are made of M.S. Sheet. It is two chambered box. The partition between the two chambers is 6cm above the bottom so that the slurry may run to the next chamber. The larger chamber is 90×63×60 cm<sup>3</sup> whose one side is glass and is used for storage of slurry as well as gas. Inside length, width and height of the digester are respectively 90 cm, 63 cm and 60 cm. So inside volume=340200 cm<sup>3</sup>= 0.3402 m<sup>3</sup>. The outlet port of slurry is 7 cm diameter and 10.16 cm long and which is made by GI. Pipe, is fitted at the side near the bottom. The smaller chamber 15×63×60 cm<sup>3</sup> whose four sides are made of MS. Sheet is used to feed slurry. In this chamber a 70×63 cm<sup>2</sup> sheet is slopping down from the top end of the bottom such that the slurry can easily entre into the chamber. A 2-way regulating valve is fitted at the top of the larger chamber. MS. Sheet was welded with the 3/4" angle bar frame to make the system air tight cementing (potting) was placed throughout the joints [6].

## Hydrogen sulfide removal system

The system consisted of a one liter sulfide oxidizing unit (SOU) connected to a pilot scale anaerobic digester, a continuous stirred tank reactor (CSTR) with an internal settling zone, that had a working volume of 92 L. The 1.5- inch ID SOU was operated with liquid height of approximately 3 feet. The effluent from the digester was occasionally pumped into the SOU to provide medium for sulfide removal.

Sulfide-laden biogas produced in the digester was mixed with a small amount of air before being forced through a fine diffuser located at the bottom of the SOU. In the SOU, hydrogen sulfide in the biogas dissolved into the medium and reacted with oxygen in the injected air to form chemical sulfur. After passing through foam trap (not shown), sulfide-free biogas exited the system. Hydraulic retention times (HRTs) of the pilot scale digester was controlled at 20 days. The digester was continuously mixed by means of biogas recirculation at the rate of 1.5 L/min (0.016 L/L digester-min) whereas the biogas recirculation rate of the SOU was set to either 0.2 or 0.4 L/min (0.2 or 0.4 L/L SOU-min). Both the SOU and the anaerobic digester were operated at a room temperature of  $25 \pm 2^\circ\text{C}$ . The liquid and the head space volumes of SOU were 1.05 and 11.1 L, respectively. Initially, the digester was inoculated with anaerobic digester sludge from a local waste water treatment plant and feed with a synthetic organic substrate. Fifteen liters of the synthetic organic substrate consist of 338.1 g of commercial dog food (with minimum 27% of crude protein, minimum of 15 % crude fat, maximum of 4% crude fiber, maximum 4% of moisture by weight), 50 g of  $\text{NaHCO}_3$  and 15 ml of trace element solution (prepared by adding 10 g of  $\text{FeCl}_2 \cdot 4\text{H}_2\text{O}$ , 2.0g of  $\text{CoCl}_2 \cdot 6\text{H}_2\text{O}$ , 1 g of EDTA, 500mg of  $\text{MnCl}_2 \cdot 4\text{H}_2\text{O}$ , 200 mg of Resazurin, 142mg of  $\text{NiCl}_2 \cdot 6\text{H}_2\text{O}$ , 123mg of  $\text{Na}_2\text{SeO}_3$ , 90mg of  $\text{AlCl}_3 \cdot 6\text{H}_2\text{O}$ , 50 mg of  $\text{H}_3\text{BO}_3$ , 50mg of  $\text{ZnCl}_2$ , 50mg of  $(\text{NH}_4)_6\text{MoO}_{24} \cdot 4\text{H}_2\text{O}$ , 38 mg of  $\text{CuCl}_2 \cdot 2\text{H}_2\text{O}$  and 1.0 ml of HCl (37.7% solution) into distilled water to make 1 liter). Substrate preparation was conducted by soaking of dog food for 1 day, adding  $\text{NaHCO}_3$  and trace element solution and adjusting the volume to 15L by tap water. The substrate was kept in a  $4^\circ\text{C}$  refrigerator prior to feeding. The organic and COD 55 loading rate to the digester were approximately 0.8 g-VS/L-day and 1.2 g-COD/L-day, respectively. Prior to the experiments, the anaerobic digester had been operated for more than a year to ensure the steady state condition was reached [7].

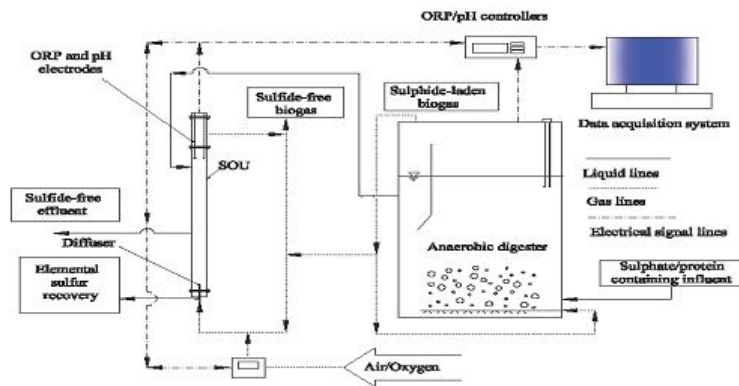

Fig. 2. Schematic of the sulfide removing system

## 5. Technical and Cost analysis

### Load calculation of the farm

The total number of sheds in the farm is 50 (each having 4 bulbs of 40w) and the total number of lights is 250. The lights are used for 4 hrs per day which consumed 10,000 watts of electricity. The farm has 3 office rooms. The total number of lights and fans are respectively which consumed 300 watts of electricity. So the total electricity consumed in the farm is 10300 watts or 10.3 kilo watts.

### Amount of poultry waste collected per day

The number of sheds in the farm is 50 and each shed contain about 1000 chickens. The amount of waste collected from each chicken is about 100gm Or 0.1kg. The total number of chickens is  $(50 \times 1000)$  50,000 and total waste collected per day is  $(50,000 \times 0.1)$  5000kg or 5 ton.

### Parameters of digester

Fixed dome type digester is used. The ratio of waste to water is 1:1, retention time is 30 days. [8] And density of the poultry waste is  $765.6 \text{ kg/m}^3$ .

Digester size (m<sup>3</sup>) = Daily feed-in (m<sup>3</sup>/day) \* Retention time (day)..... (1)

Daily feed-in = Volume of poultry waste + Volume of water..... (2)

$$= \left(\frac{m^3}{P}\right) \text{ waste} + \left(\frac{m^3}{P}\right) \text{ water} = \frac{5000kg}{765.6kg/m^3} + \frac{5000kg}{1000kg/m^3} = 6.53 + 5 = 11.53 \text{ m}^3$$

From equation (1) we have,

Digester size = 11.53 \* 30 = 346 m<sup>3</sup> ..... (3)

The digester is of cylindrical shape and the diameter (d) to depth (l) ratio is 2:1.

Volume of digester =  $\pi r^2 l$ ..... (4)

Assume depth of the digester (l) = x m and diameter (d) = 2x or radius (r) = x

From equation (2) and (3) we have,

$346 = \pi r^2 l$  or,  $346 = \pi x^2 * x$  or,  $x = 5$  m (approximate)

So, the depth of the digester is 5m and diameter is 10m. The building material of the digester is concrete and the capacity is about 150 ton. The p<sup>H</sup> inside the digester is 7 and temperature always kept above 35°C.

### Biogas generator

The amount of biogas produced 40-80 m<sup>3</sup>/hr. [9] which can efficiently run the 50kw, 400V/230V, 50/60Hz, AC three phase biogas generator.

### Cost analysis

Initial cost

1. Biogas Generator (50KW) = 70,00,000tk [10]
2. Pump (5KW) = 40,000tk [10]
3. Digester = 1,65,000tk
4. Holding tank = 87,500tk
5. Hydrogen sulfide removing unit = 250,000tk
6. Cooler = 100,000tk [10]
7. Hot water tank = 200,000tk [10]

Total initial cost 78,42,500tk

Replacement and maintenance cost: [6]

Digester cleaning = 50,000tk/2years or, 25,000tk/year (Assume) [9]

Pipe replacement = 60,000tk/year (Assume) [9]

Employee salary/month: Including one engineer and one operator total salary of the employee around is around 60,000tk/month [9]. In one year, 60,000 \* 12 = 7,20,000tk

Generator maintenance cost: [11]

Major overhauling cost = 2,00,000tk/73000hr = 20,000tk/7300hr or per year (Generator runs 20hr/day)

Top overhauling cost = 1,00,000tk/36500hr = 20,000tk/3650hr or per year

Total maintenance cost of generator per year = 20,000tk + 20,000tk = 40,000tk

Total replacement and maintenance cost per year = 60,000tk + 25,000tk + 720,000tk + 40,000tk = 8,45,000tk

### Payback period:

Electricity consumed in the farm per day is (50kw \* 4hr) 200 unit, cost per unit is 4.73tk [12] so cost of 200 unit is 946tk (commercial bill). Electricity that could be supply per day is (50kw \* 16hr) 800 unit, cost per unit is 7tk

(Assume) so cost of 800 unit is 5600tk. Total amount of electricity per day is 1000 unit. Total cost per day is (946tk + 5600tk) 6546tk. Total cost per year is (6546tk \* 365) 23,89,290tk. So per year income is 23,89,290tk

Net annual cash inflow = 23,89,290tk - 845,000tk = 15,44,290tk

Simple payback period =  $\frac{\text{Investment required}}{\text{Net annual cash inflow}} = \frac{78,42,500}{15,44,290} = 5.07 = 5$  years

Net present value (NPV): (Life time of the project = 20 years) Insert rate (Average) = 13% [5]. The net present value found is 3005,753.68 tk. Since the net present value is positive so, the project is feasible.

Internal rate of return: Internal rate of return is 19%

### 6. Recommendation for future work

More research should be made for the simplification of the biogas plant in design construction, operational aspects and raw materials. Future work may be done to analyze the component of the biogas produced from the chicken waste and supplying electricity to fulfill the farms need and selling electricity commercially. Depreciation cost may also be calculated precisely for better economic benefit.

## 7. Conclusion

This paper is an attempt to design a 50kw biogas plant from poultry waste in a poultry farm. So that the plant can supply electricity to fulfill the farms need as well as the project become profitable. Finally the following statements can be concluded-

- i. Number of chickens in the farm is 50000 and the amount of poultry waste collected per day is about 5 ton.
- ii. This 5 ton waste produces 40-80 m<sup>3</sup>/hr gas. This gas can easily run 50 kw biogas generator.
- iii. Payback period is 5 years. The investment and the running cost of the plant is recovered in about 5 years and the plant life is about 20 years. So we get profit after the 5 years.
- iv. Net present value (NPV) is positive, so the project becomes feasible.
- v. Internal rate of return is 19%.

There is a potential to produce electricity from poultry waste and high interest from farmers to produce the electricity. This interest has come due to the fact that all the poultry farms experience load shedding throughout the day mostly in the evening which hampers the production of the farms. Electricity can be produced from poultry waste for the daily consumption of most of the poultry farms.

## 8. REFERENCES

- [1] Nasir NF, Daud WRW, Kamarudin SK, Yaakob Z. Process system engineering in biodiesel production: a review. *Renew Sustainable Energy Rev* 2013; 22:631–9.
- [2] Grameen Shakti, Bangladesh. [www.gshakti.org/](http://www.gshakti.org/)
- [3] International Conference on Renewable Energies and Power Quality (ICREPQ)'12, Santiago de Compostela (Spain), accessed on 28<sup>th</sup> to 30<sup>th</sup> March,2012.
- [4] The Daily Star, 06 May, 2012.
- [5] Retrieved from [www.bangladesh-bank.org/econdata/intrate.php](http://www.bangladesh-bank.org/econdata/intrate.php) accessed on 29.12.13.
- [6] Mohammad Rashedul Islam, K.M. Ibrahim Shohag, “Design and construction of a portable biogas plant”, Undergraduate thesis paper department of Mechanical Engineering RUET, Rajshahi, Bangladesh. March 2008
- [7] Thanapong Duangmanee, “Micro-aeration for hydrogen sulfide removal from biogas” Graduate thesis paper, Iowa State University, Ames, Iowa, 2009.
- [8] Sheikh Ashraf Uz Zaman, “The potential of Electricity Generation from poultry waste in Bangladesh. A case study of Gazipur district” Graduate thesis paper, University of Flensburg, Germany, August 2007.
- [9] Poultry waste based electricity plant, Paragon Agro Limited, Gazipur, Dhaka, Bangladesh.
- [10] Energypac, Bangladesh. [www.energypac.com/power\\_gen.php](http://www.energypac.com/power_gen.php), Consulted on 23.12.13.
- [11] Shikalbaha power station, Shikalbaha, Chittagong, Bangladesh.
- [12] Bangladesh Power Development Board, Retrieved from [www.desco.org.bd/?page=tariff-rate-2](http://www.desco.org.bd/?page=tariff-rate-2) accessed on 23.12.13

## Safety Issues of Boiling Water Reactors

M. Obaidullah, I. Ahmed and M. A. R. Sarkar

<sup>1</sup>Centre for Energy Studies

<sup>2</sup>Department of Mechanical Engineering

Bangladesh University of Engineering and Technology

Dhaka 1000, Bangladesh

E-mail: irfanahmed.10118@yahoo.com

### Abstract

*The world nuclear share of electricity generation is increasing day by day. A nuclear reactor is a complex system in which the energy produced by fission nuclear reactions and the chain reaction are kept under control. Nuclear reactors can be divided into several different categories. Nuclear power is a viable, economically competitive and safe option to contribute to the high electricity demand expected for the next decades. Currently, nuclear energy is the largest source of electricity without emission of greenhouse gases. The Bangladesh government has planned to setup 4000 MW nuclear power station by 2030. In several countries, for electricity generation, the capacity factors are the highest for any type of fuel and, at same time, production costs from nuclear power are the lowest. However, public acceptance is still a major issue to overcome before nuclear power can be exploited to its fullest. Issues as nuclear plant security, waste management and reactor safety are constantly being debated by civil society. The boiling water reactor (BWR) is a type of light water nuclear reactor used for the generation of electrical power. It is the second most common type of electricity generating nuclear reactor. The Boiling water reactor safety systems are nuclear safety systems constructed in order to prevent or mitigate environmental and health hazards at the time of reactor operation as well as at the time of emergency condition. Both common and special safety features of different types boiling water reactor are discussed in this paper.*

**Keywords:** Boiling crisis, Boiling water reactor, Nucleate boiling, Passive Safety Systems, Emergency Core Cooling System.

### 1. Present Status of Nuclear Power Plant Worldwide

Because of the high performance operation of current nuclear power plants, high and volatile price of natural gas and oil, and because nuclear energy is the largest energy source without emission of greenhouse gases, nuclear power electricity generation has regained attention from the energy industry. The world nuclear share of electricity generation was about 16% during 2003. The total number of nuclear power plants worldwide generation at least 30 net MWe during this time period was 438. These power plants generated 65,852 net MWe. Compared to 2002, these were a generation increase of 2008 MWe, although there was six nuclear power plants more operating in 2003. Safe operation of nuclear plants is its highest level of priority; general public opinion still shows clear concerns regarding nuclear reactor safety. In order to provide an understanding of the safety issues during design and operation of commercial nuclear reactors, a short description of the main design and operation parameters related to nuclear reactor safety are presented here.

Nuclear safety is a set of actions taken to protect individuals, society, and the environment against radiation risks. These actions can be divided into three general groups: (a) safe normal operation of nuclear facilities; (b) prevention of transient events and accidents; (c) mitigation of the consequences of the transient events and accidents that could occur.

For a nuclear power plant, the set of actions related to safe operation imply that normal operation must be performed within specific limits and conditions. Besides normal operation, it also includes maneuvering during reactor startup, power increase and decrease, shutdown, maintenance, test and transients, which are events expected to occur to take actions to prevent significant damage to reactor components or to avoid reaching accident conditions.

The prevention of transient events and accident conditions in a nuclear power reactor is accomplished by the use of components, system and procedures, all related to safety. Accident prevention is the top priority for reactor



designers and operators. Operating personnel are required to have strong commitment to the culture of safety. Means of accident prevention include: 1) technical aspects, as emergency system used to control conditions that could lead to accident scenarios, 2) an in-depth defense strategy, which prevents the release of radioactive material by using a series of physical barriers, 3) inspections and tests, which are regularly performed on systems and components to reveal any possible malfunction or degradation.

## 2. Nuclear Reactor Designs

The main difference between a typical large nuclear power plant and one using fossil fuels is the energy source; the former involves nuclear fission and the latter chemical combustion. The other major components of the power plants are basically the same, as a steam supply system, turbine and condenser, and the electrical generator, as shown in Figure 1. Another major difference between fossil-fueled and nuclear reactor plant is that the latter have redundant safety systems.

Excluding graphite-moderated light water-cooled nuclear reactors, more than 400 reactors are cooled by gas or water. If heavy water is used as coolant, this type of nuclear reactor is referred as to Heavy Water Reactor (HWR), whereas the term Light Water Reactor (LWR) is applied to a nuclear reactor cooled by ordinary water. Two types of LWR exits: Pressurized Water Reactor (PWR) and Boiling Water Reactor (BWR). 81% of all nuclear reactors in the world are LWR type and they produce about 87% of the total nuclear power. In this paper safety aspects will be focused on LWR nuclear power plant, and more specifically in BWR plants.

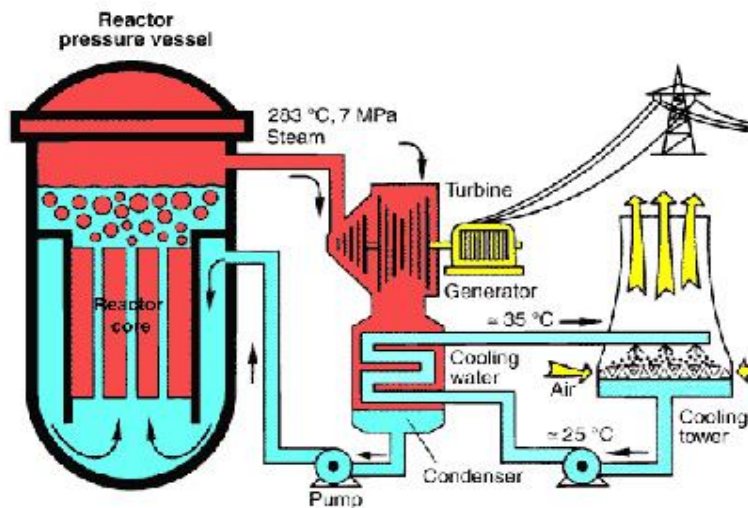
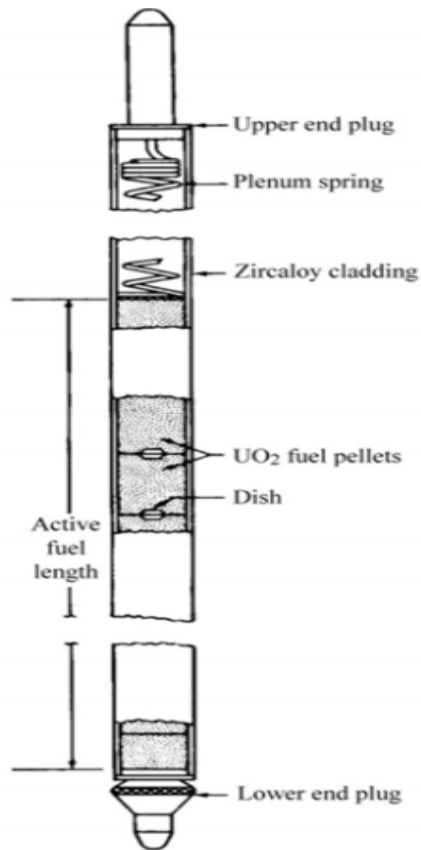

Fig. 1. Typical Boiling Water Reactor Power Plant [3]

## 3. Nuclear Reactor Safety Design

The nuclear aspects of the design of a nuclear reactor core are highly dependent on other areas of design of the power plant, as thermal hydraulics, structural analysis, economic performance, etc. Thus, the overall design of a large commercial nuclear plant is an enormous complex task that involves that involves coordination among several diverse disciplines. The design is not at all a one time, static process, but an iterative one, since the design is refined through several steps to identify and satisfy constraints, safety issues, and economic performance.

The major safety concern for a commercial nuclear power plant is to avoid the release to the environment of the large inventory of radioactive fission products accumulated in the nuclear fuel, for any foreseeable accident. To avoid such fission product escape, several safety engineering barriers exists: first the fuel pellet itself keeps the solid and some of the gaseous products in the matrix. Then, the next barrier is the fuel rod cladding, which keeps those fission products accumulated in the fuel rod gap from reaching the core coolant. Figure 2 shows the schematic of typical BWR fuel element.



**Fig. 2.** Typical Boiling Water Reactor fuel element [1]

If some fission products could leak out through the fuel rod cladding into the coolant system, the next barrier is the reactor primary system, which is the coolant piping system and the pressure vessel. If a catastrophic situation is considered, the pressure vessel could fail, and then the containment structure, that is the reactor building, is the last barrier that the fission products need to leak out through to, finally, reach out to the power plant surrounding environment. Figure 3 shows all the typical safety barriers and their features of modern BWR design.

The design of the above mentioned safety engineering barriers involves choosing the correct construction materials for each of the barriers, except, clearly, the fuel pellet, since the environment in a nuclear reactor is characterized by very high pressures, large thermal gradients, and an intense nuclear radiation field. Therefore those materials employed for the safety barriers are required to have nuclear quality, since nuclear radiations alter the properties of such materials, besides the demanding thermo-mechanical stresses.

Although the engineered safety barriers are intended to physically contain the fission products, there are additional operational measures and systems designed to take preventive action, in the event of abnormal behavior of the nuclear reactor. Separate safety systems have primarily to keep the reactor core cooled, and fully covered at all times, in case of accident. Even when the reactor is shut down, the remaining decay heat needs to be removed from the core to avoid core meltdown. These safety systems include control rods and an Emergency Core Cooling System (ECCS). The ECCS mainly includes high and low pressure coolant injection systems to keep the core fully covered.

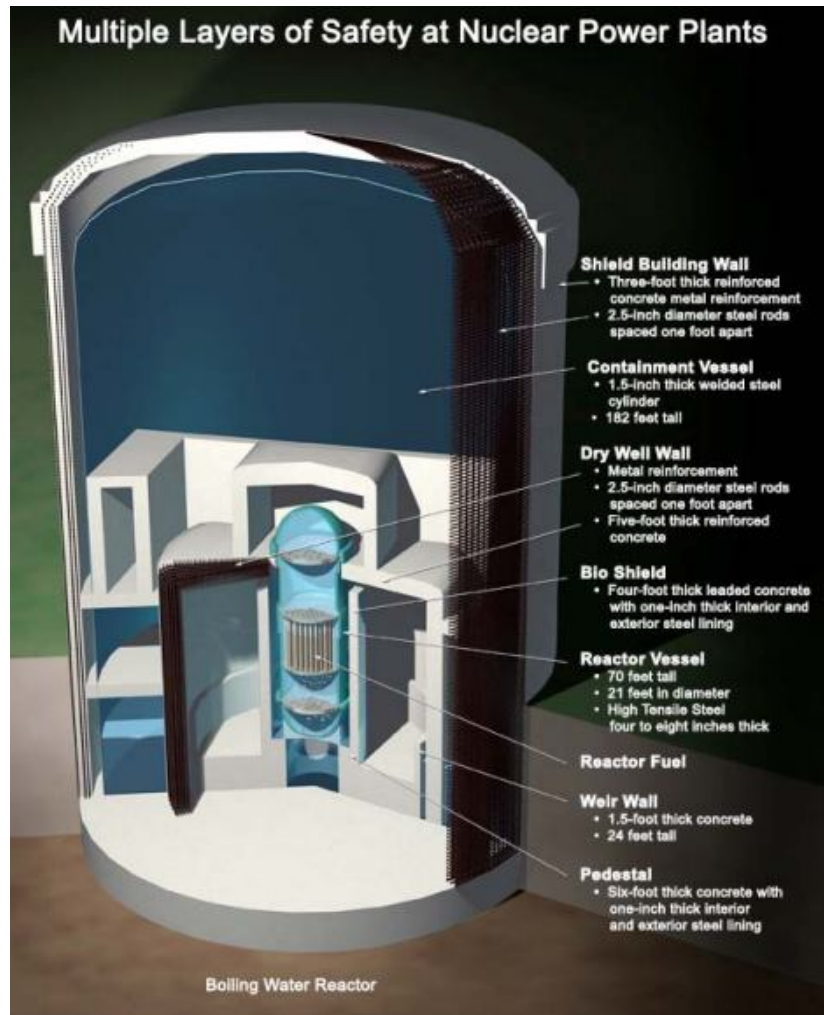

Fig. 3. Multiple layers of safety of Modern BWR [2]

#### 4. Safety Systems of Advanced Boiling Water Reactor (ABWR)

ABWRs are Generation III reactors based on the boiling water reactor. ABWR has three completely independent and redundant divisions of safety systems. The systems are mechanically separated and have no cross connections as in earlier BWRs. They are electronically separated so that each division has access to redundant sources of ac power and, for added safety, its own dedicated emergency diesel generator. Divisions are physically separated. Each division is located in a different quadrant of the reactor building, separated by fire walls. A fire, flood or loss of power which disables one division has no effect on the capability of the other safety systems. Finally, each division contains both a high and low pressure system and each system has its own dedicated heat exchanger to control core cooling and remove decay heat. One of the high pressure systems, the reactor core isolation cooling (RCIC) system, is powered by reactor steam and provides the diverse protection needed should there be a station blackout. The safety systems have the capability to keep the core covered at all times. Because of this capability and the generous thermal margins built into the fuel designs, the frequency of transients which will lead to a scram and therefore to plant shutdown have been greatly reduced (to less than one per year). In the event of a loss of coolant accident, plant response has been fully automated. Any accident resulting in a loss of reactor coolant automatically sets off the Emergency Core Cooling System (ECCS), made up of multiple safety systems, each one functioning independently. ECCS also has its own diesel-driven standby generators that take over if external power is lost.

High Pressure Core Flooder (HPCF) and Reactor Core Isolation Cooling (RCIC) systems: These systems inject water into the core to cool it and reduce reactor pressure.

Low Pressure Flooder (LPFL) system: Once pressure in the reactor vessel is reduced, this system injects water into the reactor vessel. The reactor core is then cooled safely.

Automatic-depressurization system: Should the high-pressure injection system fails, this system lowers the reactor vessel pressure to a level where the LPFL system can function.

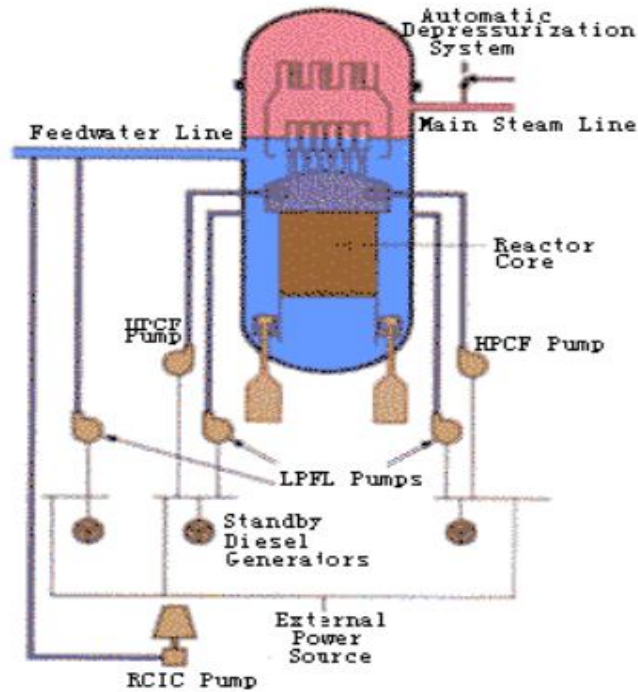

Fig. 4. Emergency Core Cooling System (ECCS) [2]

### 5. Safety Systems of Economic Simplified Boiling Water Reactor (ESBWR)

The Economic Simplified Boiling Water Reactor (ESBWR) is a passively safe generation III+ reactor which builds on the success of the ABWR. Natural circulation is consistent with the key objectives of the ESBWR program: a passive safety design with simplification achieved by evolutionary enhancements.

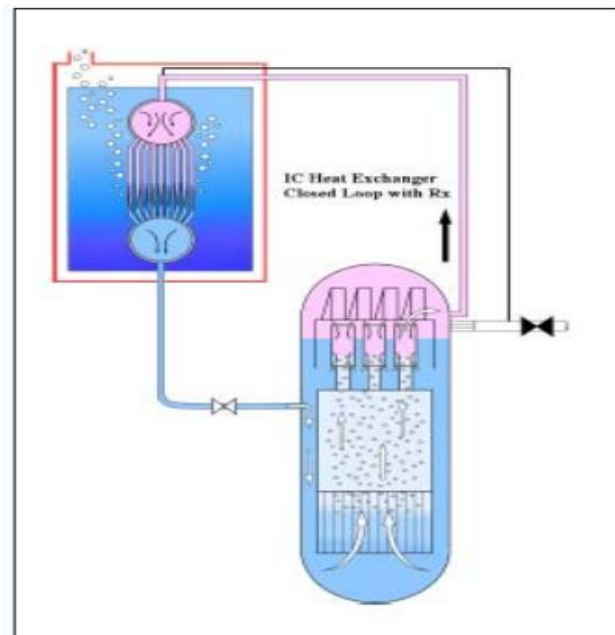

Fig. 5. Isolation Condenser System [3]

Most of the components in the ESBWR design are standard to BWRs and have been operating in the commercial nuclear energy fleet for years. The passively safe characteristics are mainly based on isolation condensers, which are heat exchangers that take steam from the vessel (Isolation Condensers, IC) or the containment (Passive Containment Cooling System, PCCS), condense the steam, transfer the heat to a water pool, and introduce the water into the vessel again. This is also based on the gravity driven cooling system (GDCS), which are pools above the vessel that when very low water level is detected in the reactor, the depressurization system opens several very large valves to reduce vessel pressure and finally to allow these GDCS pools to reflood the vessel.

## 6. Summary and Closing Remarks

(1) Safety of nuclear power plant is an on-going concern. Safety is an essential and critical issue of engineering design, and safety tends to receive greater emphasis when failure could have serious consequences.

(2) The design of the containment not letting the radiation to escape in the atmosphere is still under research. Different composite materials that can be used in designing the containment to absorb the maximum amount of radiation are currently on progress and also have been applied in modern advanced reactors.

(3) The materials which are employed for the safety barriers are required to have nuclear quality, since nuclear radiations alter the properties of such materials, besides the demanding thermo-mechanical stresses.

(4) In modern nuclear reactors active safety systems along with passive safety systems have been inherently mobilized to mitigate the critical situations.

(5) All types of safety system should be kept in proper check-up and maintenance for the assurance of their operation on due time.

(6) More research should be going on for the invention of new safety systems and for the development of the existing types.

(7) For the enhancement of safety issues, importance should be given on thermal hydraulics characteristics of nuclear reactors.

## 7. References

- [1] Javier Ortiz-Villafuerte, Yassin A. Hassan, "Safety of Boiling Water Reactors", *Encyclopedia of Life Support Systems*, Vol.2, pp. 178-190, 2004.
- [2] G. M. Ortzwell, K. Gibbs, H. K. Thomson, "Boiling Water Reactor Power Plant", *ATOMICA*, pp. 16-37, 2007.
- [3] J. Alan Beard, GE HP ESBWR Overview, *IAEA*, pp. 26-83, 2006.
- [4] Ashok Thadani, Nuclear Power Generation Guide, *Denryoku Shinnpou Sha*, pp-164-207, 1999.
- [5] H. J. Rayuku, Handbook for Thermal and Nuclear Power Engineering, *TENPES*, pp- 43-64, 2002.
- [6] K K Vaze, "Structural Integrity Aspects of Reactor Safety" *Sadhana*, Vol.13, Part5, pp991-997,2013.

## Impact of battery driven vehicle on the electricity of Rajshahi city, Bangladesh

S. Mandal<sup>1</sup>, S. Ahmed<sup>1\*</sup>, F. Rabbi<sup>1</sup>

<sup>1</sup>Department of Mechanical Engineering, Rajshahi University of Engineering & Technology (RUET),  
Rajshahi-6204, BANGLADESH

\*E-mail: [sabbir112048@gmail.com](mailto:sabbir112048@gmail.com)

### Abstract

*Bangladesh is one of the under developing third world country. Power crisis is one of the major problems in the country. As a division Rajshahi city plays a vital role in the developing of the country as well. It is a big city with almost 8 lacks people. In recent days battery driven auto rickshaw become the main transport for communication in Rajshahi. According to our research there are more than 15 thousands auto rickshaw are available in the city. But only around 10 thousands have valid license according to (RCC). To drive these auto rickshaws they need to charged everyday which consume a lot of power. For this reason there occurs serious power cut almost every day. Most of these auto rickshaws do not have valid licenses. As a result there is no accurate data about the consumption of electricity which cause a huge system loss of total electricity. The system loss fluctuates between 13 to 15 percent during the month of March to August. According the report of Bangladesh Power Distribution Board (BPDB), the total power requires for Rajshahi city is around 250 MW. But the auto rickshaws consume around 20 MW, which is about 7 to 9 percent of total amount.*

Keywords: Battery driven vehicle, power crisis, electricity, environment pollution.

### 1. Introduction

Electricity is one of the prime concerns of the development of a country. A country's socio-economic development mostly depends on the generation capacity of electricity. Bangladesh as a third world under developing country, the generation capacity of electricity is less than demand. So we need to ensure its proper use for sustainable development. Rajshahi is one of the biggest cities of Bangladesh. Now-a-days its internal transportation system mostly depends on the battery driven auto bike. Battery operated auto-rickshaw popularly known as 'Easy-bike'. Battery operated auto-rickshaw is a newly added para transit mode in urban transportation system of Bangladesh. The mode, being introduced in 2008 in Bangladesh attains much popularity among urban passengers since it involves lower travel cost than other locally available transport modes as well as provides reasonable safety and comfort to the users during travel. This popularity, in turn results rapid growth of the mode in urban areas of Bangladesh. Now, the mode has become inseparable part of urban people's mobility network, especially in small-compact towns. These batteries are charged with electricity taken from the domestic or commercial lines which indirectly burdens the national grid. Because of significant amount of electricity is used for charging the batteries of these vehicles, so, the country is experiencing tremendous shortage of electricity. As a result load shading is very common today. These electrically charged vehicles run almost all over the cities and districts of Bangladesh. So, huge number of Easy-bikes enhanced the load shading problem. Bangladesh Power Development Board (BPDB) claims that these electrically charged vehicles consume approximately 4MWhr<sup>[1]</sup> of electricity every day for charging their batteries. Before 2008, rickshaw was the major transport vehicle in Rajshahi City Corporation (RCC) area for travelling short distance but now battery run auto rickshaw has become popular for easy travelling and cheap cost. According to a private survey, there are nearly than 15,000 battery operated auto-bike, 7000 auto-rickshaw in Rajshahi Metropolitan area. According to the RCC sources, there are more than 10,000 auto-bike and 5000 auto-rickshaws moving in the city area and the RCC officials claimed that they have license to 10,000 auto bike and 4000 auto rickshaws<sup>[2]</sup>. But there are also so many others battery driven vehicles (auto bike and auto rickshaw) which are roaming around the Rajshahi city without any license. For this reason, this city is fully jam packed with these vehicles. These vehicles need a long time to be fully charged, which is one of the causes of power crisis in Rajshahi city. Here Table 1. Shows the number of auto vehicle for every 1000 people in past 5 years. Which clearly shows the rapid increasing rate of auto which definitely have a bad impact in many sector.

Table 1. Increasing rate of auto for past 5 years in Rajshahi City

Year	No. of auto	Population (million)	No. of auto for every 1000 people
2011	6000	0.65	9.2
2012	7500	0.68	11
2013	9500	0.72	13.19
2014	12000	0.77	15.85
2015	15000	0.81	18.51

Source- Rajshahi City Corporation (RCC), [Transportation sub section]

Fig.1. shows the graphical view of the table 1.

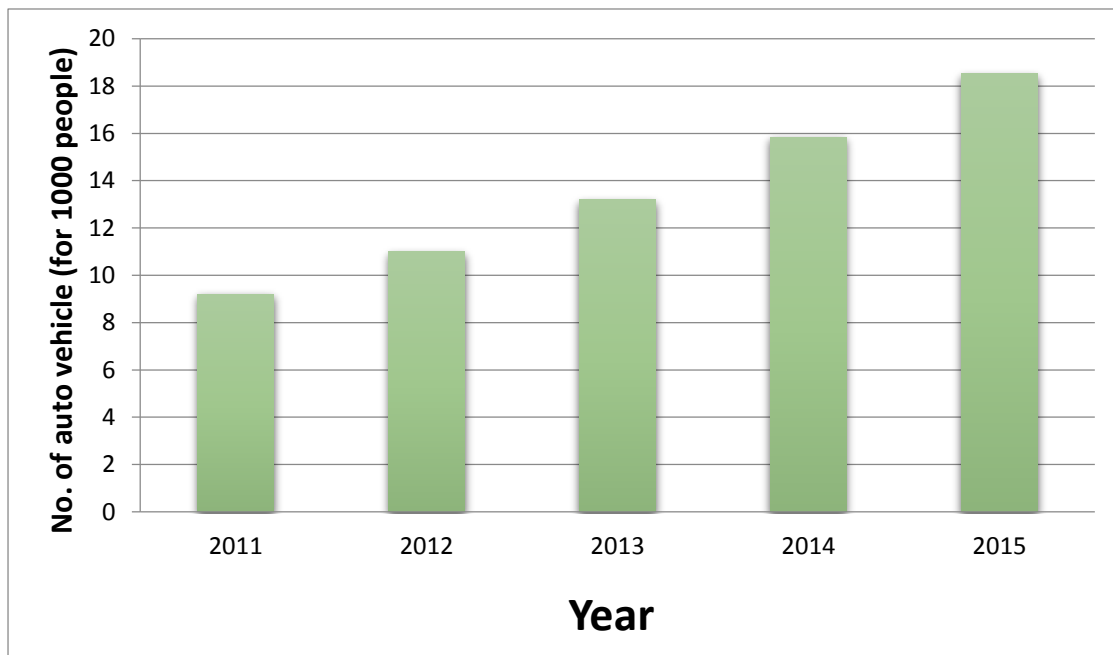

Fig.1. Number of auto vehicle for 1000 people by year

## 2. Overview of Battery driven vehicle

Batteries have advantages of being quick responsive, useful in a wide range of power levels, efficient, simple to install and easy to maintain. The Easy-bikes are built on small chassis and three small wheels. The chassis is generally made from mild steel and the body is with GI pipes. The front face is slightly aerodynamic shape, the overall dimensions are 287×105×178 cm depending on different manufacturers. The space is suitable for 6 passengers. A water-proof dc motor, powered by lead acid batteries, is used as source of power and the output of the motor is about 1000-1250 watts. The cost of Easy-bike ranges from BDT 130,000 to 160,000. Generally, 5 batteries of 12 volts in some cases 4 or 6 batteries of 12 volts totaling 60 volts and 140 amps are used. Batteries need approximately 8 hours for charging at new condition but it needs 10-12 hours after using 8-12 months. Each battery costs about BDT 20,000. The various models of Easy-bikes are now present in Bangladesh. The common models are: XINGE, DOWEDO, JET FIGHTER, MAINBON GROUP, GANGCHILL, XINGEBANG and JT TRICYCLE. Fig.2. Shows the view of a battery driven vehicle.





**Fig.2.** Battery driven vehicle

### **3. Negative impacts of battery driven vehicle**

#### **3.1 Illegal recharge point**

As day by day the numbers of auto vehicle are increasing rapidly, so demand of more recharge point is also increasing. To fulfill the demands so many recharge points are established at every corner of the city. But the main problem is most of the recharge point does not have any legal electricity connections which clearly a huge problem for any city. As a result the amount of power requirement is increasing rapidly which affects the national power grids.

#### **3.2 Less driving speed**

The battery driven vehicles are not as powerful as the diesel or petrol engine driven vehicles. So, the speed of is battery driven vehicles is much lower & is normally 35-40 Km/hr. It takes much time to reach at our destination. It will create more difficulties during the time of Traffic jam.

#### **3.3 Longer recharge time**

It takes more time to fully recharge than the petrol or diesel driven vehicles. Even most of the battery driven vehicles need to recharge twice a day. These vehicle need to be charged 8-10 hours daily. This causes hazardous situation at the filling stations as well as the national power grids.

#### **3.4 Silence**

Technology is so developed that sound proof car is available in present days for enrich passengers comfort level. Like others it also does have some bad sides. For example the fully silence car might cause more accidents, as it is difficult to detect from which side they are coming. Fortunately or unfortunately battery driven vehicles are also included within this category.

#### **3.5 Traffic jam**

According to the statistic of Rajshahi City Corporation (RCC) the total population of rajshahi city is around 8 lacks <sup>[3]</sup>. So the amount of total battery driven vehicles (auto bike and auto rickshaw) is more than the requirements. The annual growth rate of traffic is 6.1%. So the excess amount of these vehicles causes serious traffic jam at different points of Rajshahi city especially at saheb bazar, kajla and laxmipur. Fig.3 & fig 4 Shows the present scenario of traffic jam in the different places of Rajshahi city (Laxipur mor & Shaheb bazar )



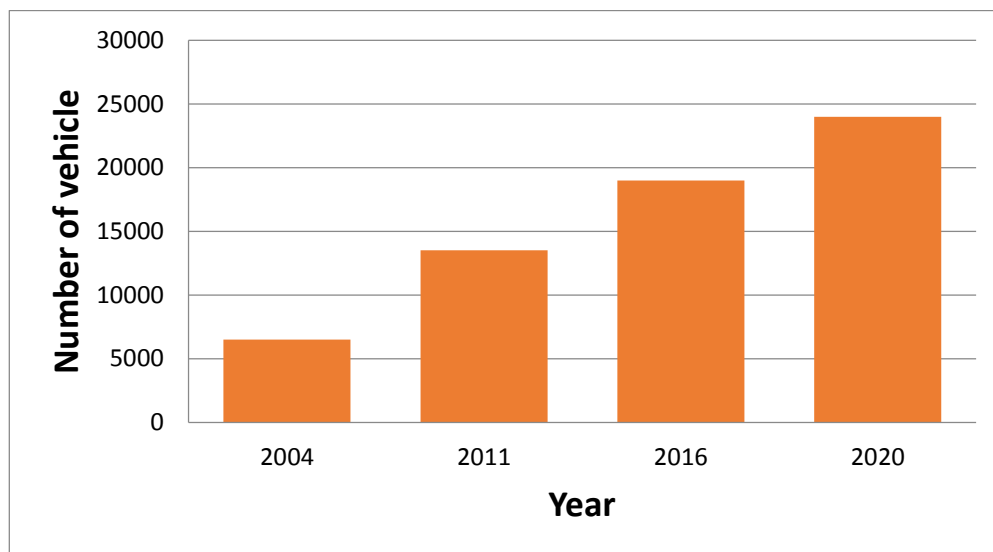

**Fig.3.** Traffic jams in Rajshahi city (Laxmipur mor)



**Fig.4.** Traffic jams in Rajshahi city (Shaheb bazar).

If this condition can't be controlled in a proper way then the amount of traffic jam will be increased rapidly and which might be uncontrollable. Fig.5. Shows an approximate traffic forecast for some previous and upcoming years if this situation is going on like this.



Source- Rajshahi City Corporation (RCC), (Transportation sub section)

**Fig.5.** Traffic forecast by years.

#### **4. Negative impacts of batteries used in vehicle**

In the Rajshahi city every auto bike & auto rickshaw is driven by battery. The battery which is used in those vehicles is lead-acid batteries. These lead-acid batteries is responsible for various problems such as-

##### **4.1 Environmental concerns**

These batteries causes numerous environmental damages on short scale. The lead present within the battery is one of the major reasons. These batteries require proper maintenance from time to time to avoid these environmental damages caused by Lead.

##### **4.2 Corrosion Issue**

Lead acid batteries are vulnerable to corrosion which frequently occurs either due to electrolysis or overfilling. Corrosion may decrease batteries life time & must be avoided through proper maintenance.

##### **4.3 Acid Fume**

Lead batteries in some cases releases hydrogen gas. Gas can cause numerous health issues in terms of long-term exposure. Normally wet cells have vents open allowing gas to escape.

#### 4.4 Sulfation

Lead Sulfate is a common problem causing major battery damage. Lead sulfate if formed causes increased level of resistance present within the battery.

#### 4.5 Cost

The costs of these batteries are also high. The initial cost of battery almost 20 thousand BDT. Also the batteries need to be changed after one year.

#### 4.6 Imbalance

Proper balancing is a prime safety concern in automobile sector. But these 3wheeler vehicles are not properly balanced. The passenger's seat is not properly arranged too. These increase the risk of accidents in the city.

### 5. Power crisis due to battery driven vehicle

Total numbers of Auto Rickshaws at Rajshahi city in Bangladesh are 15,000.

Rated power consumption:

Total voltage =  $12 \times 5 = 60$  volt.

Total power consumed =  $5 \times (12 \times 140) = 8.4$  kWh = 8.4 units

By direct observation the actual power consumption is 10 kWh. The transmission loss is 16% of actual power consumption =  $10 \times 16\% = 1.6$  kWh

So, total power supplied by the power plant = 11.6 kWh A single Auto Rickshaw needs minimum energy 11.6 kWh per day. In Rajshahi city total numbers of Auto Rickshaws are 15,000. So Auto Rickshaw consumes energy 174 MWh per day i.e. 21.75 MW<sup>[4]</sup>. Moreover by following this rule the total amount of electricity consumed by auto rickshaw is around 5 MW and the average load at Rajshahi city in Bangladesh is 250 MW<sup>[5]</sup>. The total amount of electricity consumption by auto bike and auto rickshaw is 26.75MW which 10.7% of the total load at Rajshahi city in Bangladesh. Fig.6. shows the daily load curve, which clearly indicates that for the

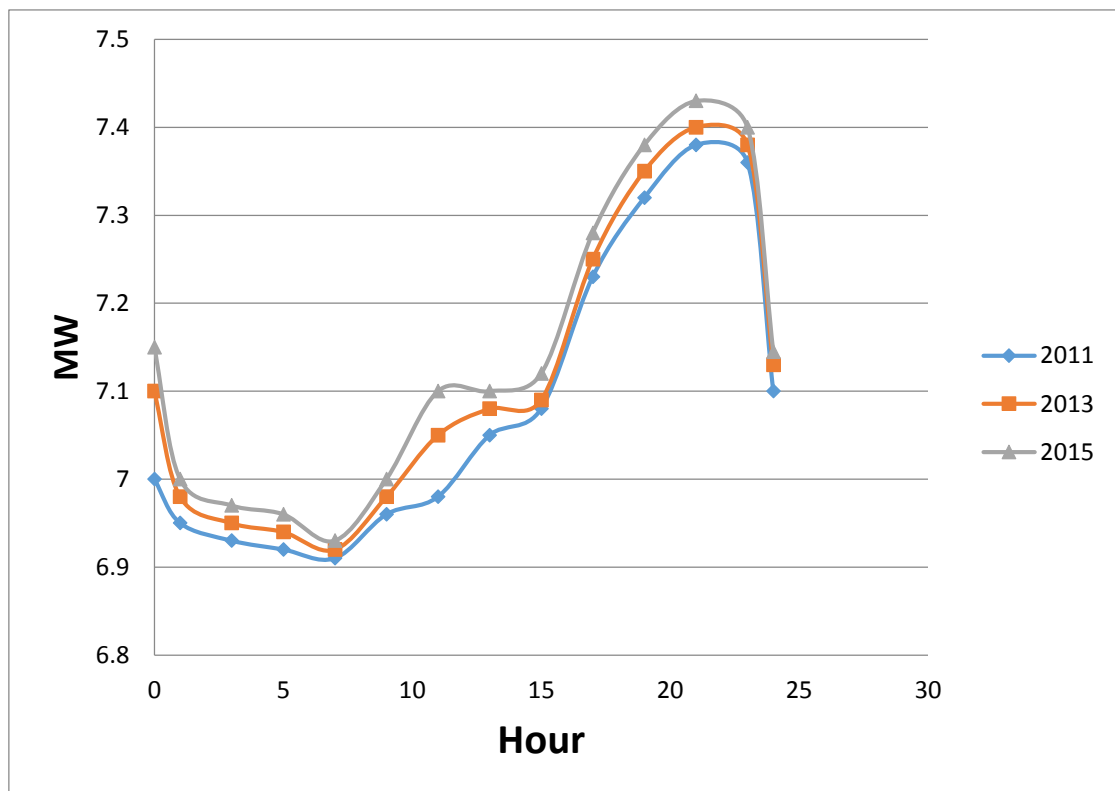

Source- [www.bpdb.gov.bd/rajshahi/](http://www.bpdb.gov.bd/rajshahi/)

Fig.6. Load curve

increasing number of auto vehicle the demand for power is also increasing. Demand should be lesser from 00:00 to 8:00 but as most of the drivers recharged their vehicle at that time the demand is increasing which obviously left bad impacts in power system.

## 6. Recommendation

- The number of auto vehicle must be decreased.
- Rechargeable battery should be modified.
- Legal action must be taken against unlicensed vehicle.
- All recharge points must have legal connections.
- Renewable energies should be introduced to recharge the batteries such as solar panel & modified wind turbine in the roof top of the vehicle.
- Disposal of batteries could be reduced by proper disposal system.

## 7. Conclusion

Rajshahi city was taken as an experimental area for this research type work. But it was difficult to calculate the actual amount of battery driven vehicle. Some important data were taken from some reliable source such as the website of BPDB. According to our research and authentic statistic, 3000-4000 auto bike and 2000 auto rickshaw will be perfect for human transportation within the city. It may save around 18MW. Which may be used in another sustainable development works.

The maintenance system must be improved and the numbers of auto rickshaw need to be controlled in proper administrative way, otherwise it will not possible to minimize the power crisis.

## 8. Acknowledgement

The supports from the Department of Mechanical Engineering of Rajshahi University of Engineering and Technology(RUET), Rajshahi City Corporation(RCC), Transportation sub section & Bangladesh power distribution board (BPDB) are gratefully acknowledged.

## References

- [1] Md.Zulkefa Rian,Dr. A. N. M. Mizanur Rahman, Study on Power Consumption and Social Aspects of Battery Operated Auto-rickshaw, International Conference on Mechanical, Industrial and Energy Engineering 2014
- [2] Rabeya Basri, Md Selim Reza, Tahmina khatun, Dr. M. Moazzem Hossain Khan Changing Modes of Transportation: A Case Study of Rajshahi City Corporation.
- [3] Rajshahi city corporation (RCC); Transportation sub section
- [4] Md. Abdur Rahim, Rahim, M. Abdur, Joardder, Mohammad Uzzal Hossain, Houque,S.M.Nazmul, Rahman, M.Mustafiz, & Sumon, Nazmul Amal, Socioeconomic & environmental impacts of battery driven auto rickshaw at Rajshahi city in Bangladesh. In International Conference on Mechanical, Industrial and Energy Engineering 2012, Khulna, Bangladesh.
- [5] Bangladesh Power Development Board <http://www.bpdb.gov.bd>

# Evaluation of Biodiesel from Rice Bran Oil as a Fuel for Automotive Applications

Abu Naushad Parvez and Sobahan Mia\*

Department of Mechanical Engineering, KUET, Khulna, Bangladesh

\*E-mail: [smia@me.kuet.ac.bd](mailto:smia@me.kuet.ac.bd)

## Abstract

*Due to increased environmental pollution and gradual depletion of the fossil fuels, it becomes necessary to develop viable alternative fuels from renewable sources for industrial as well as automotive applications. Vegetable oils seem to be a potential alternative fuel but because of some detrimental properties like high viscosity and low volatility, it causes several problems during their long duration usage in diesel (CI) engines. The most commonly used method to make vegetable oil suitable for use in diesel engines is to convert it into biodiesel i.e. vegetable oil esters using transesterification process. Rice Bran oil is an underutilized, edible vegetable oil, which is available in large quantities in rice cultivating countries and very little research on it, has been done to utilize this oil as a proper substitute to mineral diesel fuel. In this work, the transesterification process for the production of rice bran oil methyl ester has been investigated. The optimum conditions to achieve maximum yield of biodiesel has been investigated at different catalyst weight % of oil and with different molar ratio of Rice Bran oil and methanol. The most expected result has been investigated at 6:1 molar ratio of methanol and Rice Bran oil at the reaction temperature 60°C, 1h heating and stirring time, and for 1% (w/w) catalyst for high biodiesel production rate. The fuel properties, economic analysis and comparison with other edible and non-edible sources showed that the biodiesel from rice bran oil has comparable properties to substitute mineral diesel fuel in CI engines, hence, rice bran oil methyl ester can be recommended as mineral diesel fuel substitute for diesel engines especially in automotive engines.*

Keywords: Biodiesel, Rice Bran oil, Transesterification, Catalyst.

## 1. Introduction

During the past decades worldwide petroleum consumption has permanently increased due to rapid growth of human population and industrialization, which has caused depletion of the fossil fuel reserves and increased their price. On the other hand, combustion of the petroleum fuels emits greenhouse gases and contributes to environmental pollution and global warming [1]. Since most of the road vehicles are utterly dependent on these fossil fuels, thus there has been happening a severe instability of the environment and climate of the whole planet. Therefore, there is a great awareness in diesel fuel substitution with a clean, renewable fuel such as biodiesel. It facilitates 75% cleaner burning phenomena than diesel fuel, reduces the CO emission by 48%, particulate matter emission by 47%, and ozone formation probability by 67% [2]. It can be made from vegetable oils, animal fats or recycled restaurant greases. Out of these, rice bran oil is one of the most promising alternative fuels for diesel engine. It is a non conventional, inexpensive and low grade vegetable oil. Its acid value, FFA content and saponification value dignifies its approbation in biodiesel production [3]. Though various works had been pursued on biodiesel but most of them are on elementary analysis of different parts of the biodiesel production. But, many of them lacks the clarification of the RBO biodiesel usability as a fuel in automotive applications considering its overall production feasibility, fuel characteristics compared to diesel and economic perspective. So, the main purpose of this work is to produce biodiesel in an economical and effective way, to investigate the fuel properties of biodiesel from RBO, to compare it with the conventional Diesel fuel, make a standard comparison of different biodiesels made from variety of oil and finally proposes RBO biodiesel prospective as a fuel in automotive vehicles with respect of its characteristics and financial consideration.

## 2. Methodology

### 2.1 Transesterification Process

Transesterification is a chemical reaction in which alcohol reacts with triglycerides of fatty acids of vegetable oil in presence of catalyst. It is such a reversible process in which an ester is transformed into another through interchange of the alkoxy moiety [4]. The reaction is as follows:

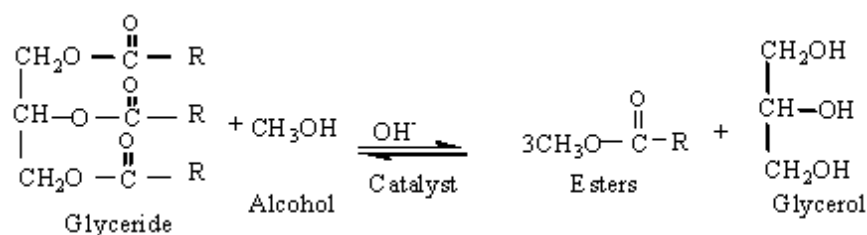

Fig. 1. Transesterification reaction

There are three types of transesterification process are available including acid-catalyzed, base-catalyzed and enzyme-catalyzed transesterification. Depending upon the FFA content, reaction time and temperature all these processes have their own certain benefits [5-10]. There are also some other processes like Heterogeneously Catalyzed process, Non-ionic Base-Catalyzed process. The above figure shows the chemical process for methyl ester biodiesel.

## 2.2 Production of Biodiesel (BD) from Rice Bran Oil

The refined and neutralized rice bran oil collected from the market contains the following substances per liter of oil:

[Moisture-0.11%, Ether insoluble matters-0.12%, Per-oxide value-4.41, Iodine value-101.42, Refractive index-1.4658, FFA content-0.25%, Acid value-0.44, Saponification value-188.61, Unsaponifiable value- 0.75%, Density at room temperature(30°C) -0.913]\* All data are collected for white gold rice bran oil (From Rashid Oil Mills Ltd [11]).

Now the selection of appropriate and economical transesterification process is the first priority for biodiesel production. Since the FFA content of the collected rice bran oil is less than 2% thus base-catalyzed transesterification is applicable. In transesterification reaction since three moles of alcohol reacts with one mole of triglycerides thus the molar ratio of oil to methanol should be 3:1. But transesterification is a reversible reaction. In order to keep the reaction always forward it is necessary to add excess alcohol. Different studies showed that a molar ratio of 5:1 to 7:1 is required for better reaction purposes. Bradshaw and Meuly (1944) showed that molar ratios greater than 5.25:1 are effective for better separation of ester and glycerol phases [10]. In such case, 3:1, 4:1, 5:1, 6:1 molar ratios had been tested, but for of 6:1 molar ratio the results were satisfactory. Much oil was extracted, soap was easily separable and glycerin settled down comfortably.

The raw materials for biodiesel production are: Methyl alcohol having 99.5% purity, density of 0.792 gm./ml and the molar mass is 32.04 gm./mole; Sodium hydroxide pellets having 99.98% purity; Rice bran oil having average molecular weight 867.90 gm./mole (source: Ying Xia Li 2011[13]). By the molar ratio 6:1 of methanol to oil, it is required 255.2 ml of methyl alcohol for 1 liter RBO (from molar ratio to volume ratio calculation). For this amount of oil to methanol, catalyst amount is 9.13 gm (for 1% catalyst) for RBO density 0.913 gm./ml. For small scale production, 250 ml RBO, 63.8 ml CH<sub>3</sub>OH and 2.283 gm. NaOH (for 1% catalyst) has been taken.



Fig. 2. Experimental setup for biodiesel production

### 2.3 Flow diagram for biodiesel production from rice bran oil

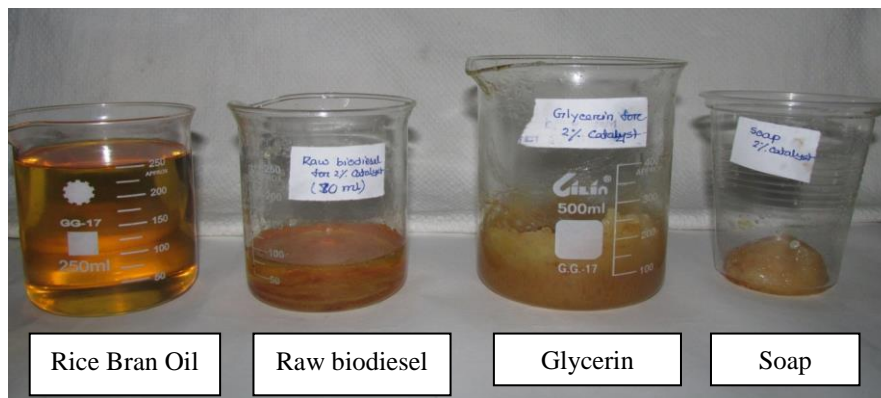
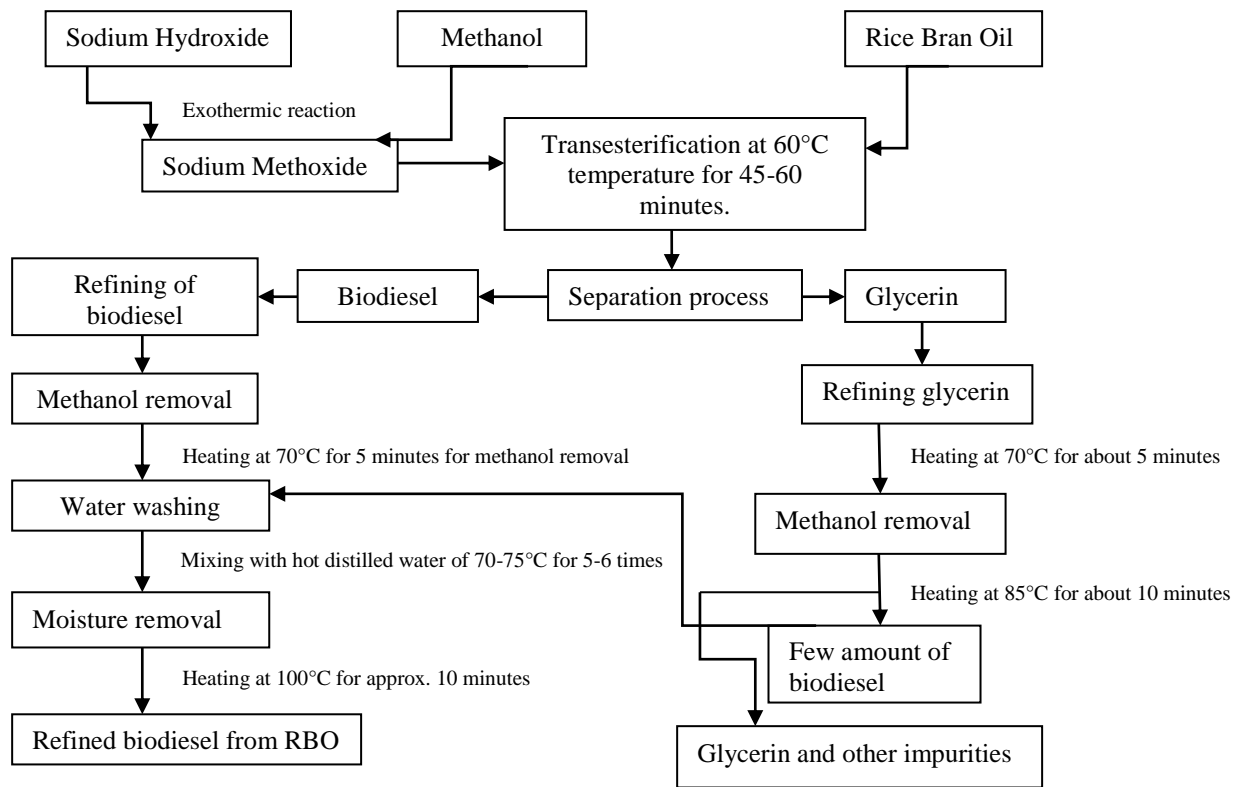

**Fig. 3.** Different stages of biodiesel production



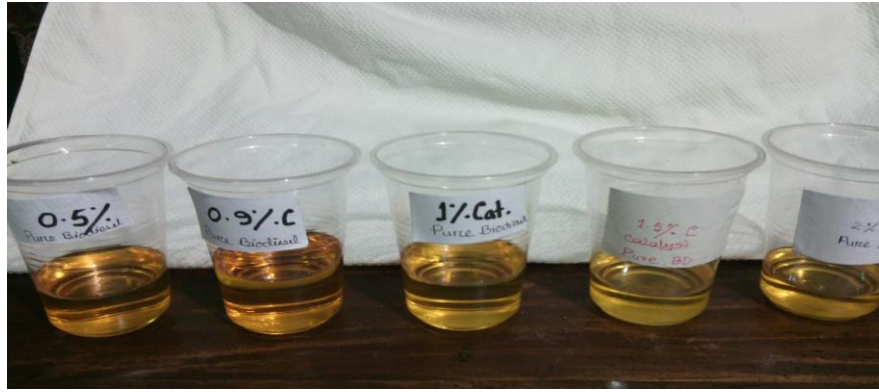

Fig. 4. Pure usable biodiesel with different percentages of catalyst

### 3. Results and Discussion

Table 1. Comparison between fuel properties of RBO, biodiesel (BD), RBO methyl ester

Serial no.	Properties	RBO	Biodiesel (for 1% catalyst)	Diesel*
1	Density(gm./ml)	0.913**	0.7561	0.82
2	Flash point(°C)	327**	Above 150°C	55
3	Boiling point(°C)	320**	334.5	248
4	Calorific value (MJ/kg)	36.99**	37.84	44.5
5	Kinematic viscosity at 30°C(mm <sup>2</sup> /s)	67.7	5.274	1.6-2.9
6	Kinematic viscosity at 40°C(mm <sup>2</sup> /s)	42.87	4.63	2.5-3.5

\*Properties are taken as standard value (source: <http://www.dieselnet.com/standards/fuels.php>)

\*\*Source: [www.rashidgroup/whitegoldricebranoil.com](http://www.rashidgroup/whitegoldricebranoil.com)

Table 2. Comparison between fuel properties of different biodiesels from different vegetable oils

Properties	Sunflower Oil BD <sub>1</sub>	Soyabean Oil BD <sub>1</sub>	Peanut Oil BD <sub>2</sub>	Rapeseed Oil BD <sub>2</sub>	Palm Oil BD <sub>2</sub>	Mahua Oil BD <sub>3</sub>	Jatropha Oil BD <sub>3</sub>	Castor Oil BD <sub>4</sub>	RBO BD
Density (gm./ml)	0.880	0.884	0.883	0.893	0.880	0.880	0.880	0.68	0.7561
Viscosity at 40°C (mm <sup>2</sup> /s)	4.2	4.08	4.9 <sup>a</sup>	4.8	5.7 <sup>a</sup>	3.98	4.84	4.8	4.63
Calorific value (MJ/kg)	40.1	39.8	33.6	40.0	33.5	37	37.2	37.37	37.84
Flash point(°C)	164	141	176	153	164	208	192	183	Above 150°C

<sup>a</sup> at 37.8°C

<sup>1</sup>Srivastava et al. [14], <sup>2</sup>Ghadge and Rehman [15], <sup>3</sup>Encinar et al. [16]

<sup>4</sup>Dept. of ME, KUET, June 2012 [17]

**Biodiesel production cost:** Biodiesel produced from 1 Liter RBO= 0.780 liter, Cost of 0.780 liter biodiesel= 322.132 BDT. Cost of 1 liter of biodiesel= 443 BDT. Prize of De-oiled rice cake, wax and gum, soap and glycerin were found= 81.48 BDT. Therefore, the neat Biodiesel production cost without methanol recovery= 361 BDT.

Table 3. Comparison between the different biodiesel production costs

Serial no.	Vegetable oil	Cost per liter(BDT)	Cost of BD without recovery (soap & glycerin) BDT	Amount of BD (liter)	Total cost of BD per liter(BDT)
1.	Castor <sup>1</sup>	74	2264	0.9	2515.55
2.	Neem <sup>2</sup>	82.5	1753.5	0.95	1845.78
3.	Jatropha <sup>3</sup>	80.5	2385	0.9	2650.5
4.	Sunflower <sup>4</sup>	167.56	305.56	0.7	436.51
5.	Coconut <sup>4</sup>	168	333.6	0.75	444.8
6.	Rice Bran	120	322.132	0.728	443

<sup>1</sup>Biodiesel from castor oil as an alternative fuel for diesel engine, Dept. of ME, KUET, June 2012

<sup>2</sup>Biodiesel from Neem oil as an alternative fuel for diesel engine, Dept. of ME, KUET, June 2012

<sup>3</sup>Biodiesel from Jatropha oil as an alternative fuel for diesel engine, Dept. of ME, KUET, March 2009

<sup>4</sup>Production of biodiesel from vegetable oil as an alternative fuel for diesel engine, Dept. of ME, KUET, March 2013

The high kinematic viscosities of the vegetable oils are generally 30-40 mm<sup>2</sup>/s at 40°C [18-19]. It is due to their large molecular weight in the range of 600-900, which is about 20 times higher than that of diesel fuel. The presence of chemically bound oxygen also lowers their heating value by about 10%. The high viscosity of vegetable oils leads to unfavorable pumping, atomization and spray characteristics [12]. Therefore, the basic part of this project was to reduce the kinematic viscosity of RBO and bring down it in the range of 1.9-6 mm<sup>2</sup>/s (ASTM standard). For this reason, transesterification method was applied to reduce the viscosity. At first, volumetric ratio of 1:5, 1:6, 1:7 of RBO to methanol were applied with the varied percentage (0.5%, 0.7%, 0.9%, 1%, 1.5%, 2%) of catalyst but the reactions were inappropriate and undesired results were observed. Then, the molar ratios of 1:5, 1:6 and 1:7 of oil to methanol were applied with the identical percentages of catalyst mentioned as before. The most promising result was observed for 1:6 molar ratio of oil to methanol with the varied percentages of catalyst. For 0.5% catalyst the amount of production was high with less amount of soap and glycerol but that required water washing 8-10 times. The kinematic viscosity was about 6.567 mm<sup>2</sup>/s, which exceeded ASTM standard for 40°C. But, for 0.9%, 1%, 1.5% and 2% catalyst use the kinematic viscosities are 5.668, 4.63, 4.3, and 4.1 mm<sup>2</sup>/s. With the increasing amount of catalyst the soap formation also increased together with the increase in glycerin formation rate. But in this case, the water washing time got decreased. The most satisfactory result was obtained for 1% catalyst use. For this percentage of catalyst use, the biodiesel production rate was high with decreased soap and glycerin formation and decreased water washing time compared to 0.5% and 0.9% catalyst use. The kinematic viscosity was observed 4.63 mm<sup>2</sup>/s, which was within the range of ASTM standard kinematic viscosity. The other fuel properties like calorific value was measured 37.84 MJ/kg, boiling point temperature 334.5°C for 1% catalyst, which shows quite better result to substitute diesel fuel use (Table.1) and other biodiesels e.g. sunflower, peanut, palm, jatropha and castor oil methyl ester (Table. 2). These fuel properties showed that rice bran oil methyl ester exhibits very close characteristics to diesel fuel and in comparison to other edible and non-edible oil methyl esters it can be suggested as one of the best substitute for diesel fuel in diesel engine. In addition, RBO biodiesel has showed a better consequence in case of financial affordability in comparison to coconut, sunflower, neem and castor oil methyl ester (Table. 3).



## 4. Conclusion

Today biodiesel is an increasingly attractive, non-toxic, biodegradable fossil fuel alternative that can be produced from a variety of renewable sources like vegetable oils, waste cooking oils, animal fats etc. Therefore, in this project, an effort has been made to produce biodiesel from rice bran oil. The primary of this work was to evaluate the biodiesel obtained from rice bran oil as a fuel in the automotive applications. To implement this a detail study on biodiesel and its importance was carried out. In the second stage, biodiesel was produced by the application of the most appropriate and economical transesterification process. The production rate of biodiesel varied for different catalyst percentages use. But highest the production rate was obtained for 1% (w/w) catalyst use. By the fuel properties of the usable biodiesel at this percentage, it was observed that it has closer properties to petroleum diesel also has better fuel characteristics in comparison to peanut, palm, jatropha, castor, mahua oil methyl esters. Through the economic analysis, it evident that the RBO methyl ester has better economic prospect compared to other biodiesels. In addition to this, rice bran oil is such an oil which is extracted from a byproduct called rice bran obtained after rice husk. Therefore, without any extra cultivation effort and without affecting the human food needs, rice bran oil is the only vegetable oil which shows a better resource and high priority in biodiesel production in mass rice cultivating countries.

## 5. References

- [1] [http://eartheasy.com/article\\_biofuels.htm](http://eartheasy.com/article_biofuels.htm)
- [2] <http://www.biodiesel.org/docs/ffs-basics/emissions-fact-sheet>.
- [3] <http://rashidgroup.com>.
- [4] Otera, Junzo, Transesterification, Chem. Rev.-1993, 93 (4), pp. 1449–1470, (1993).
- [5] E.Sandra, M.O., Tatiana, D. Augusto, D. Jeane and L. Rosane, “Biodiesel from Rice Bran Oil: Transesterification by Tin compounds”, Energy and Fuels, V-22, pp. 671-674, 2008.
- [6] L. Chao-Chin, Z. Siti, V.R. Shaik and J. Yi-Hsu Ju, “Lipase-catalyzed production of biodiesel from rice bran oil”, Journal of Chemical Technology and Biotechnology, Vol-80, pp. 331-337, 2005.
- [7] Y. Watanabe, Y. Shimada, A. Sugihara, H. Noda, H. Fukuda, Y. Tomonaga, “Continuous production of biodiesel fuel from vegetable oil using immobilized Candida Antarctica lipase”, J. Am. Oil Chem. Soc., Vol-77 (4), pp. 355–359, 2009.
- [8] Sridharan R. and I.M. Mathai, “Transesterification Reactions”, J.Scient. Ind. Res., 1974, vol-33, pp. 178-187, 1974.
- [9] B.N. Haq, H.A. Muhammad, Faruq Umar, S.A. Munir, “Acid and Base-catalyzed Transesterification of Animal Fats to Biodiesel”, Iran. J. Chem. Engg., Vol. 27, No. 4 (2008).
- [10] Ma Fanguri Hanna, Milford A., “Biodiesel Production: A review”, Bioresource Technology, Vol-70, pp. 1-15, 1999.
- [11] <http://www.rashidgroup.com>
- [12] Krishnakumar J., June 2009, “Production, Characterization and Emission analysis of Biodiesel”, Society of Thermal Engineers of Serbia and Montenegro, Vol-12(2), pp. 159-169, December 2008.
- [13] Ying Xia Li, Jian Wei yang, Feng Li Hui, Wei Wei Fan and Ying Yang, “Optimization of biodiesel production from Rice bran oil via immobilized lipase catalysis”, African Journal of Biotechnology, Vol-10(72), pp.16314-16324, 16 November 2011
- [14] Srivastava A., Prasad R., “Triglycerides-based diesel fuels”, Renewable sustainable energy 111-33, Rev 2004.
- [15] Ghadge SV, Rehman H., “Process optimization for biodiesel production from mahua oil using response surface methodology”, Biores Technol, 2005.
- [16] Encinar JM, Gonjalez JF, Reinas AR, “Biodiesel from used frying oil, variables affecting the yields and characteristics of the biodiesel”, Ind. Engg. Chem., Vol-44, pp. 5491-9, 2005.
- [17] Atikur Rahman, “Biodiesel from Castor oil as an alternative fuel for Diesel Engine”, Department of Mechanical Engineering, Khulna University of Engineering & Technology, Khulna, Bangladesh, June 2012.
- [18] Lin L., Dong Y., Sumpun C. and Saritporn V., “Biodiesel from crude rice bran oil and properties as fuel”, Applied Energy 86 (2009), pp. 681-688,(July 2008).
- [19] Goering CE, Schwab AW, Daughtery MJ, Pryde EH, Heakin AJ, “Fuel properties of eleven vegetable oils”, Trans ASAE, Vol-85, pp. 1742-83, 1982.

## Seismic Design Considerations for Nuclear Power Reactors

M.A.R. Sarkar<sup>\*1</sup>, I. Ahmed<sup>\*2</sup>, R. Islam<sup>\*3</sup> and M ALI Zulquarnain<sup>\*\*4</sup>

\* Department of Mechanical Engineering, Bangladesh University of Engineering and Technology,

\*\* Member Planning, BAEC, Sher-E-Bangla-Nagar, Dhaka 1000, Bangladesh.

E-mail: irfanahmed.me@gmail.com

### Abstract

*Nuclear power reactors pose special problems of earthquake safety that are different from those encountered in the earthquake for a coal-steam power generating station. In case of the nuclear power reactor, the occurrence of earthquake damage could lead to uncontrolled nuclear fission with the possibility of explosion and release of fission products into the atmosphere. One of the most severe operating conditions for a reactor is a loss of coolant accident (LOCA), which can lead to a reactor core meltdown.*

*Two levels of seismic ground motion should be considered during Nuclear power plant design. The S1 level is the level of ground motion which can be reasonably expected to be experienced at the site area once during the operating life of the plant. The S2 level ground motion is the maximum potential vibratory ground motion at the site based on the maximum earthquake potential of the (site) region. Proper measures which should be taken considering these two motions have been discussed in this paper.*

*This paper reports a complete overview of seismic design considerations of nuclear power reactors.*

**Keywords:** Earthquake, Reactor, Structure, Operate.

### 1. Introduction

Experience of the March 11 2011, Great Tohoku earthquake clearly demonstrated that the earthquakes might be the dominating contributors to the overall risk of nuclear power plants (Institute of Nuclear Power Operations [INPO], 2011); International Atomic Energy Agency [IAEA], 2007). The seismic probabilistic safety assessments of several nuclear power plants are also provided similar results. On the other hand, experiences show that plants survive much larger earthquakes than those considered in the design base, as it was the case of Kashiwazaki-Kariwa plant, where the safety classified structures, systems and components survived the Niigata-Chuetsu-Oki earthquake in 2007 without damage and loss of function (IAEA, 2007). In spite of the nuclear catastrophe of the Fukushima Daiichi plant caused by the tsunami after Great Tohoku earthquake 11th of March 2011, the behavior of thirteen nuclear unit in the impacted area on the East-shore of the Honshu Island demonstrated high earthquake resistance. Consequently, proper understanding and assessment of the safety for the case earthquake (and generally for the external hazards) is very important for the operating nuclear power plants. For the operating plants basic questions to be answered are:

Whether the nuclear power plant (NPP) is safe enough within the design basis and whether the operation can be continued safely if an earthquake hits the plant. The designer and operators were mainly focusing on the first question, i.e. whether the reactor can be shut down, cooled-down, the residual heat can be removed from the core and spent-fuel stored at the plant, and the radioactive releases can be limited below the acceptable level in case of an earthquake [1].

The second question became important especially after series of events when large nuclear capacities were shut down for assessment of plant post-earthquake condition and justification of safety before their restart. In this paper following subjects have been discussed:

- Safe shutdown condition for BWR and PWR during emergency
- Relationship between Peak Ground Acceleration (PGA) and Instrumental Intensity
- Classification of Seismic Design
- Formulation of Design Basis Earthquake Ground Motion (DBEGM)

### 2. Safe Shutdown Condition

### Safe Shutdown Condition for Boiling Water Reactor

In the case of events that cause a nuclear power plant to exceed its operating parameters (for example, an earthquake or a critical component's failure) design safety features must provide a means to control reactivity and cool the reactor [1]. During normal operation, reactor cooling relies on the water that enters the reactor vessel and the generated steam that exits. During safe shutdown, after the fission process is halted, the reactor core continues to generate heat by radioactive decay and generates steam. The heat from this a radioactive decay initially equals about 6% of the heat produced by the reactor at full power and gradually declines. Under this condition, the steam bypasses the turbine and diverts directly to the condenser to cool the reactor. When the reactor vessel pressure decreases to approximately 50 psi, the shutdown-cooling mode removes residual heat by pumping water from the reactor recirculation loop through a heat exchanger and back to the reactor via the recirculation loop. The recirculation loop design limits the number of pipes that penetrate the reactor vessel [2].

A typical boiling water reactor has been presented in the figure along with containment structure design. BWRs are inherently simpler designs than other light water reactor types. Since they heat water and generate steam directly inside the reactor vessel, they have fewer components than pressurized water reactors.

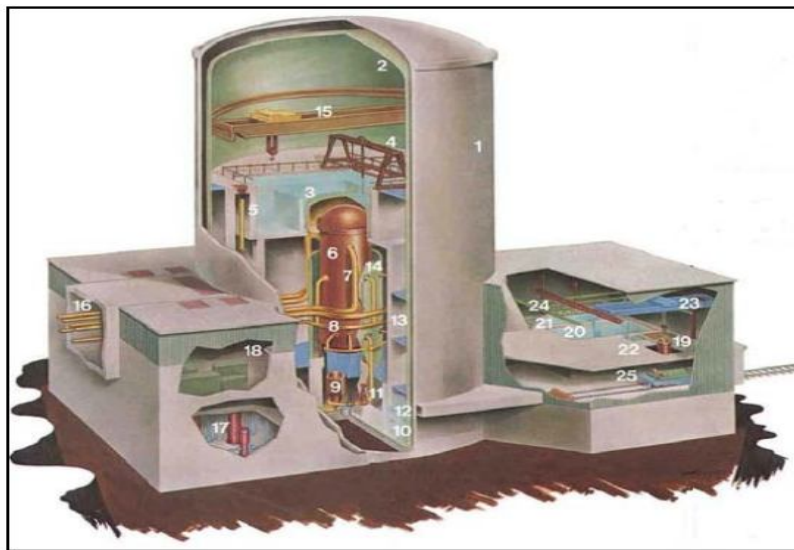

Fig. 1. General Electric Mark III Containment Structure [7]

Reactor Building	Auxiliary Building	Fuel Building
1. Shield Building	16. Steam Line Channel	19. Spent Fuel Shipping cask
2. Free Standing Steel Containment	17. RHR System	20. Fuel Storage Pool
3. Upper Pool	18. Electrical Equipment Room	21. Fuel Transfer Pool
4. Refueling Platform		22. Cask Loading Pool
5. Reactor Water Cleanup		23. Cask Handling Crane
6. Reactor Vessel		24. Fuel Transfer Bridge
7. Steam Line		25. Fuel Cask Skid on Railroad Car
8. Feed-water Line		
9. Recirculation Loop		
10. Suppression Pool		
11. Weir Wall		
12. Horizontal Vent		
13. Dry Well		
14. Shield Wall		
15. Polar Crane		

### PWR Safe Shutdown Condition

During normal operation, a PWR does not generate steam directly. For cooling, it transfers heat via the reactor primary coolant to a secondary coolant in the steam generators. There, the secondary coolant water is boiled into steam and sent to the main turbine to generate electricity. Even after shutdown (when the moderated uranium fission is halted), the reactor continues to produce a significant amount of heat from decay of uranium fission products (decay heat). The decay heat is sufficient to cause fuel damage if the core cooling is inadequate. Auxiliary feed water systems and the steam dump systems work together to remove the decay heat from the reactor. If a system for dumping built-up steam is not available or inoperative, atmospheric relief valves can dump the steam directly to the atmosphere. Under normal operating conditions, water flowing through the secondary system does not contact the reactor core; dumped-steam does not present a radiological release.

As with BWRs, the most severe operating condition affecting a PWR is the loss of coolant accident (LOCA); the extreme case represented by the double-ended guillotine break (DEGB) [6] of large diameter pipe systems. In the event of a LOCA, the reactor's emergency core cooling system (ECCS) provides core cooling to minimize fuel damage by injecting large amounts of cool, borated water into the reactor coolant system from a storage tank. The borated water stops the fission process by absorbing neutrons, and thus aids in shutting down the reactor. The ECCS on the PWR consists of four separate systems: the high-pressure injection (or charging) system, the intermediate pressure injection system, the cold leg accumulators, and the low-pressure injection system (residual heat removal). The high-pressure injection system provides water to the core during emergencies in which reactor coolant-system pressure remains relatively high (such as small breaks in the reactor coolant system, steam break accidents, and leaks of reactor coolant through a steam generator tube to the secondary side) [2]. The intermediate pressure injection system responds to emergency conditions under which the primary pressure stays relatively high; for example, small to intermediate size primary breaks. The cold leg accumulators operate without electrical power by using a pressurized nitrogen gas bubble on the top of tanks that contain large amounts of borated water. The low-pressure injection system removes residual heat by injecting water from the refueling water storage tank into the reactor coolant system during large breaks (which would cause very low reactor coolant-system pressure) [3].

### 3. Relationship between Peak Ground Acceleration (PGA) and Instrumental Intensity

Peak ground acceleration (PGA) is a measure of earthquake acceleration on the ground and an important input parameter for earthquake engineering. Unlike the Richter and moment magnitude scales, it is not a measure of the total energy (magnitude, or size) of an earthquake, but rather of how hard the earth shakes in a given geographic area [4]. The peak horizontal acceleration (PHA) is the most commonly used type of ground acceleration in seismic design consideration of nuclear power reactor. Earthquake energy is dispersed in waves from the epicenter, causing ground movement horizontally (in two directions) and vertically. PGA records the acceleration of these movements, while peak ground velocity is the greatest speed reached by the ground, and peak displacement is the distance moved. Peak ground acceleration can be expressed in *g* (the acceleration due to Earth's gravity, equivalent to *g*-force) as either a decimal or percentage; in  $m/s^2$ . [4] Correlation between Mercalli Scale and PGA has been given below:

<b>Instrumental Intensity</b>	<b>Acceleration (g)</b>	<b>Velocity (cm/s)</b>	<b>Perceived Shaking</b>	<b>Potential Damage</b>
I	< 0.0017	< 0.1	Not felt	None
II-III	0.0017 - 0.014	0.1 - 1.1	Weak	None
IV	0.014 - 0.039	1.1 - 3.4	Light	None
V	0.039 - 0.092	3.4 - 8.1	Moderate	Very light
VI	0.092 - 0.18	8.1 - 16	Strong	Light
VII	0.18 - 0.34	16 - 31	Very strong	Moderate
VIII	0.34 - 0.65	31 - 60	Severe	Moderate to heavy
IX	0.65 - 1.24	60 - 116	Violent	Heavy
X+	> 1.24	> 116	Extreme	Very heavy

Fig. 2. Relationship between Instrumental Intensity and PGA [7]

At the time of designing nuclear reactor the PGA level of that place should be taken into consideration.

#### **4. Classification of Importance in Seismic Design**

Importance in seismic design of the Facilities shall be classified as in the following [2], considering the possible impacts of radiation to the environment caused by an earthquake.

##### **(1) Classification of Functions**

**Class S:** The Facilities containing radioactive materials or their relevant Facilities, loss of functions of which might lead to the release of the radioactive materials to the environment; the Facilities necessary to prevent such events; and the Facilities with significant roles to mitigate the consequences of radioactive release in case such accidents occur,

**Class B:** The Facilities of the same functional categories as above Class S, with lower roles,

**Class C:** The Facilities other than Class S or B, necessary to ensure equivalent safety as conventional industrial facilities.

##### **(2) Facilities of Classes**

Following are the specific Facilities in the above-defined classification of importance in the seismic design,

###### **(a) Class S Facilities:**

- (i) Equipment/piping systems composing the 'reactor coolant pressure boundaries'.
- (ii) The Facilities to store spent fuels.
- (iii) The Facilities to insert negative reactivity to quickly shut down the reactor and the facilities to maintain the reactor in the shutdown mode.
- (iv) The Facilities to remove the decay heat from the reactor core after reactor is shut down.
- (v) The Facilities to remove the decay heat from the reactor core after the accident of the loss of reactor coolant pressure boundaries,
- (vi) The Facilities to function as the pressure barrier for preventing the immediate release of radioactive materials when the reactor coolant pressure boundaries are broken.
- (vii) The Facilities, other than those in the above category to mitigate the radioactive release to the environment at an accident which may cause radioactive release.

###### **(b) Class B Facilities:**

- i) The Facilities directly connected to the reactor coolant pressure boundaries, which contain or may contain radioactive materials therein [8].
- ii) The Facilities containing radioactive wastes, but not those facilities which have sufficiently low risks of radiological exposure to the public due to their break as compared with the annual exposure dose limit outside the peripheral observation area, because of their limited inventory of radioactive waste or their storage capabilities.
- iii) The Facilities relevant to radioactive material other than radioactive waste and their break may cause excessive radiological exposure to the public and the operational personnel.
- iv) The Facilities to cool the spent fuels.
- v) The Facilities other than Class S, to mitigate external release of radioactive materials to the environment at an accident.

###### **(c) Class C Facilities:**

Those Facilities other than Class S or B

#### **5. Formulation of Design Basis Earthquake Ground Motion (DBEGM)**

The ground motion to be established as the seismic design basis of the Facilities shall be formulated appropriately as the one, postulating to occur in a very low probability over the service period of the Facilities from the seismological and earthquake engineering point of view on geology, geological structures, seismicity, etc. in the vicinity of the proposed site, and having risks to give serious damages to the Facilities (the "Design Basis Earthquake Ground Motion (DBEGM) Ss") [4].

DBEGM Ss shall be formulated on the following principles.

- (1) DBEGM Ss shall be formulated as the following two types of earthquake ground motions in the horizontal and vertical directions on the free surface of the base stratum at the proposed site: The "Earthquake ground motions with the site specific earthquake source locations"; and the "Earthquake ground motions with no such specific source locations.
- (2) The DBEGM Ss for the earthquake ground motions with the site specific epicenter shall be formulated on the following principles.

- (a) Earthquakes (more than one) are assumed which may have severe impacts to the proposed site, taking account of the characteristics of active faults, the earthquakes experienced in the past and at present in the vicinity, and classifying these earthquakes by their outbreak modes (hereinafter referred to as “Earthquakes for investigation”).
- (b) Following consideration shall be made concerning the ‘characteristics of the active faults around the proposed site’ in (a) above.
  - i) The active faults to be considered in the seismic design shall be identified as the one whose activities since the late Pleistocene epoch cannot be denied. The faults can be identified depending upon whether or not the displacement and deformation exist by the faults in the stratum or on the geomorphic surface formed during the last interglacial period.
  - ii) The active faults shall be thoroughly investigated by integrating geomorphological, geological and geophysical methods, etc. to make clear their locations, shapes, activity characteristics, etc. as a function of the distance from the proposed site.
- (c) For each “Earthquake for investigation” selected in (a) above, DBEGM shall be formulated by the following two evaluation methodologies, respectively: i) with the response spectra; and ii) by the method with fault models [5]. In evaluating the earthquake ground motions, sufficient consideration shall be made to the various characteristics due to the earthquake breakout modes, seismic wave propagation channels, etc. (including the regional peculiarities).
  - i) Evaluation of earthquake ground motions with response spectra for respective “Earthquakes for investigation,” responses spectra shall be evaluated by appropriate methods and the design response spectra shall be defined based on these spectra [4]. Earthquake ground motions shall be evaluated appropriately in considering their characteristics such as duration times, time dependent change of amplitude-enveloping curves suitably.
  - ii) Evaluation of earthquake ground motions by the method with fault models for respective “Earthquakes for investigation,” earthquake grounds motions shall be evaluated by setting the epicenter characteristics parameters with appropriate methods.

## 6. Summary and Closing Remarks

- (1) Seismic Design Considerations of nuclear power reactor are important cause during earthquake situation the condition of reactors may venerable and bring catastrophe without those particular steps.
- (2) The design earthquake and the associated impacts shall be specified on the basis of the results of Deterministic and probabilistic analyses.
- (3) The results of the probabilistic and deterministic procedures shall be compared and differences explained. The design earthquake is specified under consideration of the reliability of the results of the deterministic and probabilistic analyses. In case of doubt, the larger seismic impacts shall be referred to as design parameters. The specification of the relevant parameters shall be substantiated.
- (4) Seismological surveys shall be traceable and reviewable. The data used shall completely be enclosed, unless not generally accessible, to the survey in a suitable manner.
- (5) Safe shutdown arrangement should be ensured to control the decay heat and prevent the reactor core melt down.
- (6) Post-earthquake actions should be planned for a nuclear power plant, even if an automatic scram system is installed.
- (7) The immediate notification of the regulatory body and its involvement in the restarting of the plant should be specified in appropriate procedures.
- (8) Recommendations and guidance on operational procedures following an earthquake, including the timing of, responsibilities for and tracking of the necessary actions, should be ensured.

## 11. References

- [1] Tamas Janos Katona “Seismic Safety Analysis and Upgrading of Operating Nuclear Power Plant”, *INTECH*, Vol.1, No.4, pp. 77-121, 2012.
- [2] Antony Andrews, Peter Folger, “Nuclear Power Plant Design And Seismic Safety Consideration”, *Congress Research Service*, Paper No.R41805, pp. 1-37, 2012.
- [3] In-Kil, Young-Sun Choun, Jeong-Moon Seo, “ Scenario Earthquakes for Korean Nuclear Power Plant Site Considering Active Faults” *SMIRT17*, 2003.
- [4] Robin K. McGuire, Walter J. Silva, Roger Kenneally “New Seismic Design Spectra For Nuclear Power Plants” *Pacific ngineering and analysis*, Paper No:14,2000.

- [5] K K Vaze, “ Structural Integrity Aspects of Reactor Safety” *Sadhana*, Vol.13,Part.5,pp.991-997, 2013
- [6] R.I. Skinner, R. G. Tyler, S. B. Hodder, “Isolation of Nuclear Power Plants From Earthquake Attack” pp.199-204,1986.
- [7] Aybars Gupinar, “Seismic Re-Evolution and Upgrading of Nuclear Power Plants” *IAEA*,1993.
- [8] “Seismic Design Considerations of Nuclear fuel Cycle Facilities”, *IAEA*, 2001.

## Analysis of Speed Breaker Mechanism for More Effective Electricity Generation

Md. Rokonzaman<sup>1</sup> and Md. Hossam-E-Haider<sup>2</sup>

<sup>1,2</sup>Department of Electrical, Electronic and Communication Engineering

<sup>1,2</sup>Military Institute of Science and Technology (MIST)

Email: ragib\_isme@yahoo.com<sup>1</sup>

### Abstract

*Modern industrialized civilization mostly depends on energy in the form of electricity. It is going to refractory to produce huge amount of energy. Since the population is rising, the environment is going unbalance by pollution, global warming and different kinds of deregulation of energy usage and wastage. Speed breaker is a newest source of technology to renew the wastage energy of vehicle to electrical energy during the passing time through every speed breaking hump. This paper investigates and analysis two practically implemented process of electricity generation from speed breaker named roller mechanism and rack-pinion mechanism. It can be surely effective to reduce the huge power crisis in the near upcoming days for rapidly development of infrastructure especially for developing country like Bangladesh. Where population is thriving dramatically and vehicles are flourishing proportional with the ascending rate of population. Ultimately the increased vehicle is rising up the wastage of energy and this mechanism picks the wastage energy for renew it to electrical energy by thinking out of box for generation of electricity. Though the amount of electricity depends on the number of vehicle pass over the speed hump and weight of the carrying vehicle which drops on the speed breaker and how much efficiently the system is designed then two different research paper has shown the huge capacity to generate electricity. This paper represents a comparative study of both mechanism to find out the best one from them and in-depth analysis will suggest a combined mechanism.*

**Keywords:** Electricity generation, rack-pinion mechanism, roller mechanism, renewable sources.

### 1. Introduction

Highly increased living standard and rapidity of industrialization causes the demand of electricity and it's raised dramatically, but the generation of electricity does not raised in the same scale as demand. In Bangladesh only about 32% of the total population has access to use electricity and 6% to natural gas. But in rural area only 22% has electricity [1]. Though from year 1850-2005 production and use of traditional energy increases more than 50% with a total of approximately 0.2 billion to 11.4 billion toe (IEA, 2007), mostly in industrialized nations [2]. To compete with this demand alternate thinking of energy sources are getting popular day by day. Renewable energy consist the concept which synchronizes with solar, wind, biogas, biomass; tidal etc. energy and these are cooperative to meet the demand. Though this energy sources are not highly capable to minimize the shortage of electricity generation. Recently a new technique is introduced called speed breaker technology to produce electricity from the speed breaker used in road and high ways. Main theme of this technique is to convert mechanical energy to electrical energy. Different mechanisms like rack pinion, roller, crank-shaft are used to enhance electricity from speed breaker [3]-[6]. Roller fitted in the road and vehicle passing over the speed breaker are the source of generating electricity [6]. Another one is efficient energy generating system using speed breaker with rack-pinion mechanism [7]. Both of the mechanisms are experimentally implemented and effective. This paper represents a comparative study of two techniques and proposed a combined new mechanism.

### 2. Methodology

This section is introducing the Rack-Pinion and Roller mechanism respectively.

#### 2.1 Rack Pinion Mechanism



Fig. 1. Shows block diagram of the rack-pinion mechanism. Here Speed breaker will be in the top of whole system, this will directly connected with a rack. Rack is designed with many mortise, depending on it the pinion is designed.

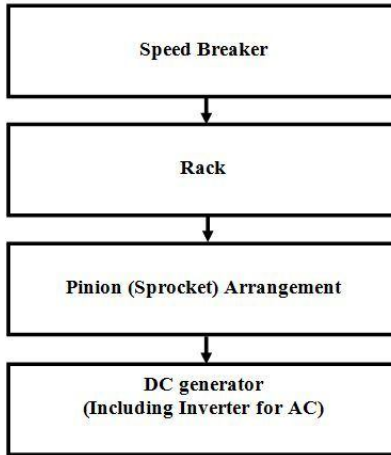

**Fig. 1.** Block diagram of rack-pinion mechanism

In this method one rack and two pinion is used, by client choice it can be increased and it will provide more rotation to the shaft of the generator. In the end of rack a spring is connected to force it reverse and a small sprocket is placed with it to rotate another large pinion. This large pinion helps to rotate the generator shaft directly. This system produces DC electricity, if required for ac electricity an inverter can be used.

### 2.1.1 Constructional Details

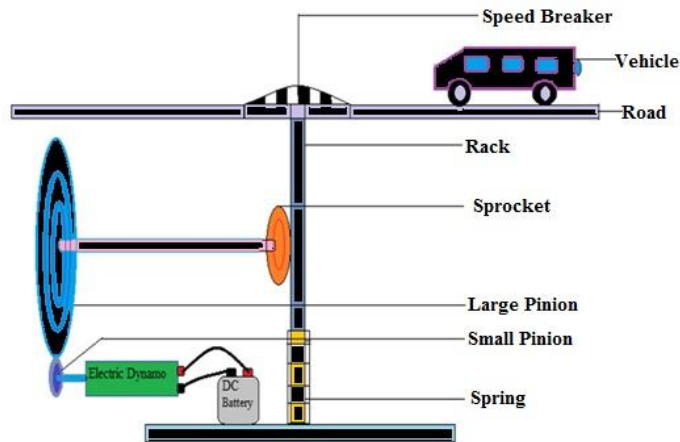

**Fig. 2.**Equipment used in rack-pinion techniques [7].

Fig. 2.Represents all the parameters used in this techniques. When the vehicles passes over the speed breaker, rack will continuously moves to the downward direction and directly rotates the sprocket and pinion respectively. Since the pinion is directly connected to the shaft of the DC generator, it will generate electricity. The position and time of the rack in downward direction depend on the speed and transitional period of stay of moving vehicle over the speed breaker [7].

### 2.2 Roller Mechanism

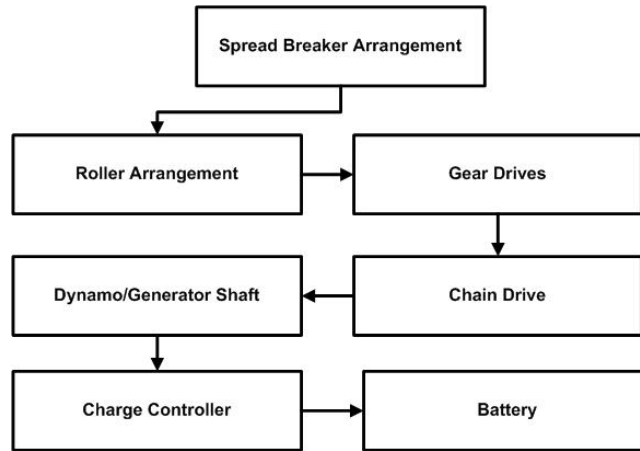

**Fig. 3.** Block diagram of roller mechanism

Fig.3. shows a single block diagram to represent the whole system of roller mechanism. Here, the rotational energy from roller is converted to mechanical energy by chain drive then it converted to electrical energy by dynamo and finally it stores in the battery. From battery or directly we can connect this energy sources to the load.

### 2.2.2 Constructional Details

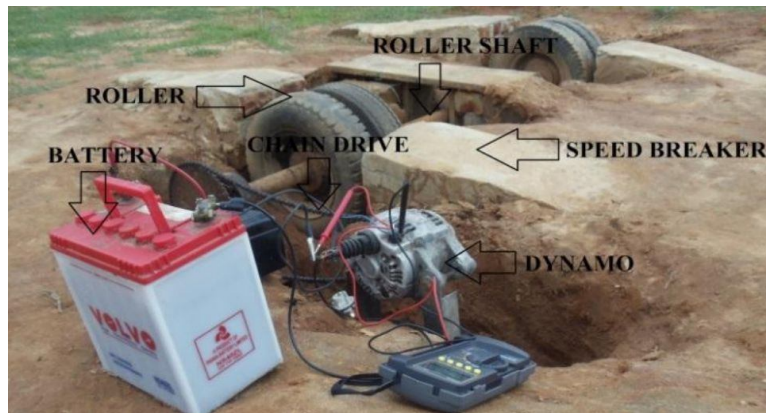

**Fig.4.** Parameters are used in roller mechanism [8].

Fig.4. represents all the parameters are used to implement the total system. The height of the speed breaker or the roller is 8 inch and there is a minimum gap between the speed breakers and the roller to obtain maximum rotation. Roller is iron made but outer surface is covered by rubber. Gear ratio is 1:4 and its mesh with another toothed part of the chain drive. Chain drive is a way to transmit the mechanical energy from roller to the shaft of the dynamo. Dynamo directly generates electrical energy to output, by converting the mechanical energy as input. Battery stores the electrical energy and helps to provide energy in no vehicle passing time.

### 3. Comparison of Two Methods

Rack and pinion method is meant to extract the mechanical energy of moving vehicles that converts into energy through rack-pinion arrangement. Produced Energy from the vehicle passing over the speed breaker drives the shaft that acts as causal agent for shaft rotation of DC generator. In roller shaft method the wasted energy is generate electricity by roller mechanism. Rack and pinion method depends on spring whereas roller shaft does not. Usage of spring sometime might result in rustic problem. The major

disadvantage of multiple sprocket freewheel is that the drive-side bearing is located inboard of the free wheel. This might further result in stress on the axel. As a result of which the axel might bend or even break. Table 1. Shows a comparison between the two methods:

**Table 1.**Comparison between rack-pinion and roller mechanism

Sl. No	Parameters	RollerMethod	Rack-PinionMethod
1	Cost	Cheap	Moderate
2	Mechanismsetup	Veryeasy	Difficult
3	Maintenance	Highly required	Less required
4	Efficiency	~50%	~70%
5	Design	Easy todesign	Depends upon weight Sustaining capacity
7	Height	5.08 cm	12 cm
6	Dependency	Mostly in roller	Mostly in spring

### 3.1 Data Comparison

In rack-pinion mechanism, when one vehicle passing over the speed breaker in 60 second, it generates 19.62 watts [7]. In Roller mechanism, if one vehicle passes in 4 sec over the speed breaker power generated 8.1 watt [8]. For 60 sec it increased to 121.5 watts. Let consider in 24 hour is continuous functional time of the speed breaker. Table 2. Shows a tabular form of the different power generated by two distinguish method.

**Table 2.** Comparison between two generated powers by two methods

<i>Time(Sec)</i>	<i>Power in rack-pinion Mechanism (watts)</i>	<i>Power in roller Mechanism (watts)</i>
60(1 min)	19.62	121.5
3600 (60 min)	1177.2	7290
21600 (6 hour)	7063.2	43740
86400 (24 hour)	28252.8 (28.25 kW)	174960 (174.96 kW)

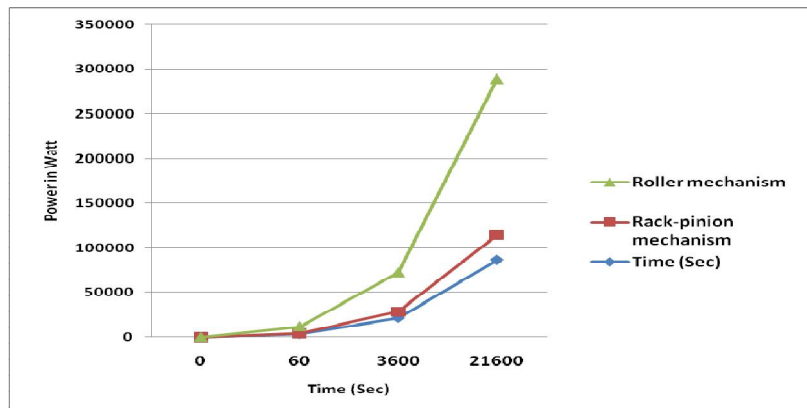

**Fig. 5.** Graphical comparison of power Vs time between two mechanisms

Fig. 5. Represent graphical data of generated power in 24 hour. Here, 6 hour is considered as useful time of the speed breaker. This plot is showing that power generation from rack-pinion mechanism is less than roller mechanism. To get more efficient power, we can combine both of the mechanism. This paper is proposed a combined mechanism to make a fruitful techniques using speed breaker.

#### 4. Proposed Mechanism

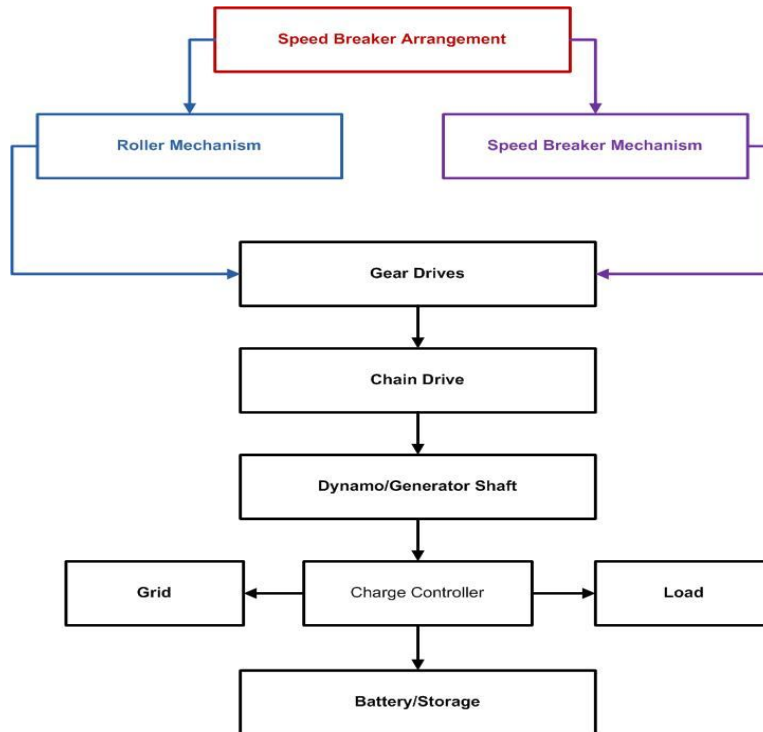

**Fig. 6.** Block diagram of proposed mechanism

Fig. 6. Show proposed block diagram of combined mechanism. It will increase the efficiency of the whole system because of integrating two mechanisms but it's true that maintenance will be hard. Charge controller will provide a smooth output which can be employed to grid or directly load as per need base. Authors are trying to practically implement this idea of combined mechanism and this paper is a partial part of it.

#### 5. Conclusion

Utilizing non-conventional energy sources has received much attention in Bangladesh for electricity generation. To manage the electricity crisis and global warming impact. This paper proposed a combined mechanism of rack-pinion and roller shaft. Rack-pinion techniques are easy to implement, economical too. Besides, roller shaft techniques are difficult to design but generate huge number of electricity. Combination of these two mechanisms can therefore be more effective to generate electricity for a protracted time. Although initial results have verified the increased electricity generating capacity, practically further implementation and analysis will be considered in future work. The combine mechanism will be able to reduce some lacking for design of each single mechanism and surely it will raise the generation capacity.

#### 6. References

- [1] Md. Ashrafal Alam, "Renewable energy for sustainable Bangladesh (part-1)", Energy and Environment, 2012.
- [2] Dilip ahuja and Marika Tatsutani, "Sustainable energy for developing countries", 2.1, Vol.2/N°1, 2009.
- [3] V. Aswathaman, M. Priyadharshini., "Every speed breaker is now a source of power", International Conference on Biology, Environment and Chemistry IPCBEE, vol.1, IACSIT Press, Singapore, pages 234 -236, 2011.
- [4] S. Srivastava, A. Asthana, "Produce electricity by the use of speed breakers", Journal of engineering research and studies, Vol. 2, Issue 1, pages 163-165, april-june 2011.
- [5] N. Fatima, J. Mustafa, "Production of electricity by the method of road power generation", International journal of advances in electronics and electrical engineering, IJAEEE, vol. 1, no. 1, pages 9-14, 2011.
- [6] C.K Das, S.M. Hossain, S.M Hossain; "Introducing speed breaker as a power generation unit for minor needs." International Conference on Informatics, Electronics & Vision (ICIEV), Dhaka, Pages 1-6, 17-18 May 2013.
- [7] Mohammed Hossam-E-Haider and Md. Rokonuzzaman "Design of an Efficient Energy Generating Systems Using Speed Breaker for Bangladesh" The 5th National Symposium on Information Technology: Towards Smart World from 17-19 February, 2015, King Saud University (KSU), Riyadh, Saudi Arabia.
- [8] Shah Mohazzem Hossain, C.K. Das, Md. Shahadat hossain, Sams Jerin, "Electricity from wasted energy of the moving vehicle using speed breaker", Jurnal Teknologi, Vol. 73, No.1, 2015.

## Study and Construction of Evacuated Tube Solar Collector

Tasnuva Tabassum Choudhury, Md. Faisal Faruk, Morshed Alam  
Department of Mechanical Engineering, RUET, Rajshahi-6204, Bangladesh.  
E-mail: faisal.ruet.me10@gmail.com

### Abstract

*Solar energy is non-polluting and eco-friendly. Its importance is on high track. Solar energy can be used into heat energy by using evacuated tube collector, flat plate collector, parabolic collector etc. Evacuated tube collector requires two layer glass tube with vacuum tubes with layers as insulation but ready-made evacuated tubes are not found anywhere in our country. So, as an alternative forms of an evacuated tube collector, fused tube light can be used. Unlike flat plate collectors, evacuated tube collectors do not heat the water directly within the tubes. Air is removed or evacuated from the space between the two tubes, forming a vacuum. By using fused tube light, it is very important for our country. It is low cost product while our country is developing country. This paper indicates study of the evacuated tube collector, how to construct an evacuated tube collector by using wasted or fused tube light. This paper also discusses the efficiency of the evacuated tube solar collector. This paper also finds the application such as water heating, space heating, cooking etc. Globally, the industries of solar evacuated tube collectors are growing at 15% annually.*

**Keywords:** Evacuated tube collector, Solar energy, water heating, wasted or fused tube light.

### 1. Introduction

The continuous rise and competitive demands for fossil fuel necessitate the need for alternative source of renewable energy. In present, Conventional energy source such as fossil fuels are decreasing day by day at faster rate. In today's world, global warming is becoming a serious issue slowly but steadily too. Developing countries like Bangladesh are in a vulnerable situation in matters of energy demand. So, the interest of renewable energy has been revived over last few years, especially after global awareness and conventional energy crisis. Now-a-days, the demand of renewable energy sources like solar energy, wind, biomass, small hydro are increasing day by day. This paper indicates solar energy. It is clean and cheap. Vacuum tube solar collector is one of the most suitable ways of applying solar energy. In our country, summer weather is almost in seven months. There is another problem in our country that two layer borosilicate glass is not available. So, We have decided that fused or wasted tube light can be used. There are many fused tube light in our country which are almost misused. By using fused tube light, We save our wasted material. It is also low cost project. The main motivation behind this concept came from international ideas of evacuated tube solar collector and novelty of this thought in our country. Several countries are now enjoying the blessings of solar energy by utilizing it in reduction of electrical energy consumed by electrical machines. Some of the companies developing evacuated tube solar collectors are Apricus, SunMaxx, Solar Cool and Northern Lights etc. Evacuated tube collectors are a slightly more recently developed technology, introduced to the market in the 1970's. E. Speyer, 1965, Studied on solar energy collection using evacuated no tracking collectors with selective coatings. Recently evacuated tube collectors are most extensively used device to convert solar radiation into heat. Evacuated tube collector is more efficient in high temperature. Dr. S. P. Vendan, L. P. A. Shunmuganathan, T. Manojkumar, C. Shiva Thanu [1], 2012, Studied on Design of an Evacuated Tube Solar Collector for High Temperature Steam Generation. Dilip Mishra, Dr. N. K. Saikhedkar [2], 2014, Studied on Evacuated U-Tube Solar Water Heating System.

### 2. Comparison between flat plate collector and evacuated tube solar collector

In evacuated tube, heat loss is minimum due to vacuum tubes. It is more efficient in high temperature than flat collector. Maintaining vacuum is difficult for evacuated tube collector. Evacuated tube is more expensive than flat collector because of many glass tubes are needed. If one of the tubes breaks or fails, tube replacement is simple and cheap. So, maintenance cost is quite low. It is another advantage of evacuated tube. Smaller collector area required to match energy output of flat plate collectors. For low temperature application, flat plate is more efficient. For but high temperature application, Evacuated tube is used.

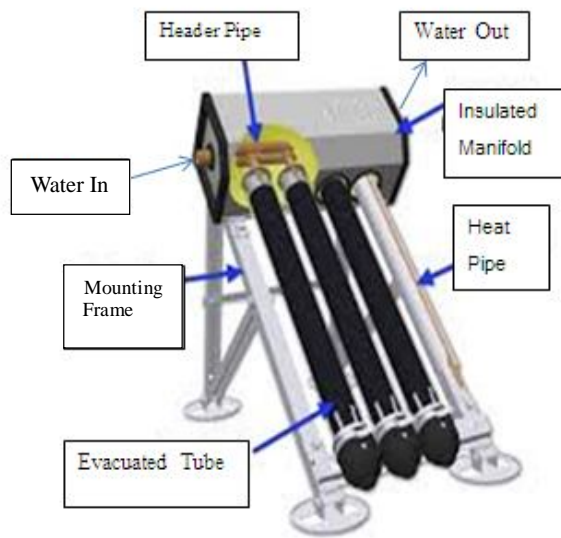

**Fig.1.** Elements of an evacuated tube collector **Fig.2.** Experimental set-up

### 3. Construction of Evacuated Tubes

There are several elements of an evacuated tube collector such as evacuated tube, heat pipe, copper header, manifold, mounting frame etc. Now elements will be discussed below.

#### 3.1 Evacuated tube

Evacuated tube is two layer glass. It consists of borosilicate glass for greater thermal efficiency. But borosilicate glass is not available in our country. So, it has been decided that evacuated tube will be constructed from fused or wasted tube light. The two terminal points of tube light are connected with aluminum cover. Aluminum cover must be loosened by slight forcing system and cover can be removed. Aluminum cover must be dipped into water at high temperature and cover can be removed also. By electrical heating system, aluminum cover can be removed. Then, gas should be removed from the tube light. Citric acid can be used to remove white color of the tube.

#### 3.2 Heat pipe

The heart of the evacuated tube solar collector is heat pipe. It is hollow element that is partially filled with a working fluid and has two sections, an evaporator and a condenser. A liquid is heated to its boiling point, evaporator and absorbs heat and uses it to convert working fluid to vapor, which expands to fill the entire internal space of heat pipe. The condenser is in direct contact with heat sink and rejects heat leading to the vapor losing the heat and condensing back to liquid. The liquid returns to evaporator and the cycle repeats itself. So it can be said the heat pipe has a diode function. A heat pipe works in the same way as a high conductance thermal conductor. Its thermal-physical properties make its heat transfer rate thousands of times greater than that of the best solid heat conductor of the same dimensions. In an evacuated tube solar collector a sealed copper pipe is coated with a thin absorber film inside the evacuated glass tube. A small copper condenser is attached to the top of each heat pipe. The common working fluids are acetone, water and methanol and common heat pipe materials are copper, iron, aluminum. Here acetone was chosen as working fluid and copper was chosen as heat pipe material. Because copper has the highest thermal conductivity of the available materials and acetone is suitable with copper. Acetone has quite a low boiling point at atmospheric pressure and under lower pressure it will be advantageous. Acetone is locally available. In table(1) gives the properties of different working fluids at atmospheric pressure and their useful ranges why we use acetone. And table(2) gives the thermal conductivity of some materials why we use copper.

## Design, Construction and Performance Test of a Solar Powered Prototype Vehicle

Md. Shazib Uddin, S. Mandal, Mehadi Hasan Masud and M. Mourshed

Department of Mechanical Engineering  
Rajshahi University of Engineering and Technology  
Rajshahi-6204, Bangladesh  
E-mail: shazib0397@gmail.com

### Abstract

*Solar power vehicle is the exciting issues to the transportation sector in the context of fossil energy crisis. A solar power prototype vehicle has been designed, constructed and performance test were carried out in this study. The vehicle is constructed using the locally available raw materials. The experimental investigation shows that the vehicle can run 1.87 km/h with load of 2 kg. The vehicle not requires conventional operating energy as it operates by rechargeable battery charged with the help of solar photovoltaic cell. If the automotive vehicles are design with the aid of solar energy instead of fossil fuel then energy crisis can be significantly solve globally and also in Bangladesh. This will also reduce the environment emissions in home and abroad.*

Keywords: Solar energy, Prototype vehicle, Energy crisis.

### 1. Introduction

The demand of petroleum over the world will be driven by the motorization of passenger transport and the continuing growth of international trade. World motor vehicle ownership will increase more than 2 billion in 2030 compared to about one fourth today due to modernization, urbanization and other factors [1]. The vehicles are fossil based engine operation. There is substantial uncertainty about how much conventional oil remains in the world for future generation. There are varieties alternative resources already invented to run the engine instead of fossil fuel but still have limitations to use 100%. Besides, worldwide transportation fuel use is projected to double by 2050 despite significant energy efficiency gains [2]. So, reliable and renewable energy sources are important in the transportation sector to overcome the limitations. Solar energy is the renewable, pollution free energy and available over the world. Many technologies have been found to conversion/utilization of solar energy into useful energy in practice. But in transportation section the utilization of solar energy is poor. But solar can play an important role to minimize the dependent on fossil energy. Solar technologies are broadly characterized as either passive solar or active solar depending on the way they capture, convert and distribute sunlight. Active solar techniques include the use of photovoltaic panels and solar thermal collectors (with electrical or mechanical equipment) to convert sunlight into useful outputs. Passive solar techniques include orienting a building to the Sun, selecting materials with favorable thermal mass or light dispersing properties, and designing spaces that naturally circulate air [3]. When sunlight (photons) strikes on PV cells, they excite electrons and allow them to flow, creating an electrical current. PV cells are made of semiconductor materials such as silicon and alloys of indium, gallium and nitrogen. Silicon is the most common material used and has an efficiency of 15-20% [4]. Design, construction and performance test of an automotive vehicle has been undertaken in this work with the help of PV cell and rechargeable batteries with an aim to reduce the use of fossil energy in the transportation sectors. The novelty of this work is the use of locally available raw materials and low cost system investigation. This construction will helps to make motor vehicle in practical with alternating energy sources and can reduce the energy demand in the context of energy crisis.



## 2. Design

A fixed small locally available solar panel considered in this work with available dimensions of 25 cm length, 18 cm width, 0.75 cm thickness and weight of 0.4 kg. The main parts used are plastic wheels, metallic gear, mild steel chassis, shafts, fittings, DC motor and battery. The dimension of the body is selected as per dimension of the solar panel used.

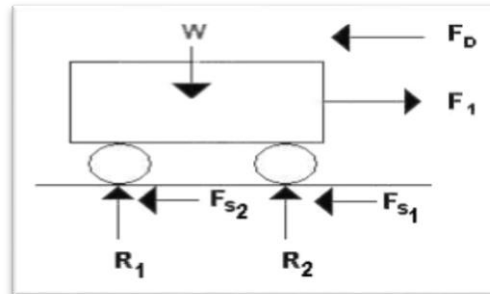

**Fig. 1.** Load balance of vehicle

Weight of the body with accessories 1.80 kg.

Total weight of the vehicle 2.20 kg.

From theory of load balance in dynamics [5-7]

$$\sum R = R_1 + R_2$$

$$\Rightarrow W = mg$$

$$\Rightarrow W = R = 2.20 * 9.81 = 21.58 \text{ N}$$

Friction force  $F_s$

For Plastic and Concrete  $\mu_R = 0.035$

Wheel radius  $r = 3.10 \text{ cm}$

From theory of rolling friction [5-7]

$$\begin{aligned} F_s &= \mu_R * (\sum R / r) \\ &= 0.035 * (21.58 / 0.031) \\ &= 24.36 \text{ N} \end{aligned}$$

Resisting force  $F_R = F_s + F_D$

Since the drag force arise above 25 mph and its speed will not much higher so  $F_D = 0$

$$F_R = 24.36 \text{ N}$$

Now,  $F_1$  must be higher than  $F_R$  to run the vehicle.

Let, the value of  $F_1 = 24.46 \text{ N}$

The Force Balance [5-7]

$$\sum F = ma$$

$$F_1 - F_R = 0.05481 \text{ N}$$

$$\Rightarrow 24.46 - 24.36 = 2.20 * a$$

$$\Rightarrow \text{Acceleration } a = 0.045 \text{ m/s}^2$$

Thrust for the vehicle  $= ma$

$$= 2.20 * 0.045 \text{ kg.m/s}^2$$

$$= 0.099 \text{ N}$$

Power required for initial motion  $P_{req} = F_1 * \text{thrust}$

$$\Rightarrow P_{req} = 24.46 * 0.099 = 2.42 \text{ W}$$

Now,  $v^2 = u^2 + 2as$  [for 1 m]

$$\Rightarrow v^2 = 0 + 2 * 0.045 * 1$$

$$\Rightarrow v = 0.30 \text{ m/s}$$

Power required to keep the vehicle in motion

$$= F_t * v = 0.0297 \text{ W}$$

So the vehicle require more than 2.42W continuously to run.

One DC motor considered to deliver the power.

Maximum Output Power by the Solar Panel is  $(8.85 \times 0.52) = 4.60\text{W}$

A battery of 8.4V selected whose maximum power output  $8.4 \times 0.52 = 4.36\text{W}$

The Maximum Input to the Motor by the Solar Panel with batteries is  $4.60\text{W} (> 2.42\text{W})$ , which is Sufficient to Run the vehicle.

**Maximum Load Carrying Capacity-**

The available power =  $4.60 - 2.42\text{W} = 2.18\text{ W}$

$P_{\text{req}} = F_1 \times F$

or,  $2.18 = 24.46 \times F$

or,  $F = 0.089\text{ N}$

therefore,  $F = ma$

or,  $0.089 = m \times 0.045$

or,  $m = 1.98\text{ kg}$

it is theoretical value of load

Again, speed  $u = \frac{\pi D N}{60}$

Here , Diameter of wheel,  $D = 6.2\text{ cm}$

Revolution of wheel,  $N = 422\text{ rpm}$

Therefore,  $U = \frac{\pi \times 0.062 \times 422}{60}$

$= 1.36\text{ ms}^{-1} = 4.89\text{ kmh}^{-1}$

The vehicle will run at the rate of  $4.89\text{ kmh}^{-1}$  with a load of  $2.00\text{kg}$ .

**2. Construction**

Mild steel material was chosen for the chassis due to high load carrying capacity. Four plastic wheels light in weight, small cast iron bevel gear arrangement, two transmitting shaft, one DC motor, necessary nuts/bolts and 8 volt battery were considered to construct the vehicle. Gear material chosen on the basis of wearing and machinability property. Bevel gear can transmit power with high velocity ratio.

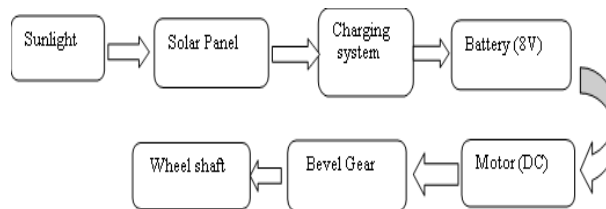

**Fig. 2.** Layout of vehicle construction

The motor fit with chassis at a suitable position connecting a shaft with pinion gear and mesh with bevel gear arrangement. The motor takes the power from the battery connected by wire. All the equipment arrange in a compact manner with the body. Charging system is basically electrical system. The rechargeable battery here used is rated at 8.0 volts and needs a charging voltage of around 8.0-8.4 volts to reach full capacity. Therefore to charge the batteries required 8.5 or 9 volt support 4W solar panel is available in the market. Note that all batteries charged at the same time should have the same capacity.

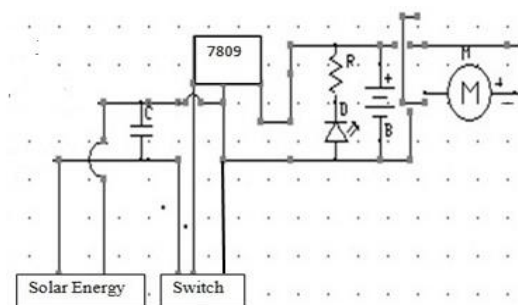

**Fig. 3.** Charging system

So, charging equipments were chosen according to the battery conditions. A polar capacitor, 7809 control regulating IC, diodes, kilo ohm resistors, LED, SPDT switches (single pole double throw) were considered for construction the charging system.

### 3. Results and discussion

The results and discussion of this study is described in the following subsection.

#### 3.1 Charging performance

Figure 4 shows the variation of voltage of the solar panel with time of the day. From the figure it is seen that, the voltage increases with increasing time. The voltage is maximum of 8.85 V at 2.30 PM. The variation occurs due to the variation of solar intensity. Radiation intensity higher causes higher electron excitation on the panel and higher voltage. The charging system is designed with 8V, hence the performance is reasonable the charging system is well enough to charge the battery to run the vehicle.

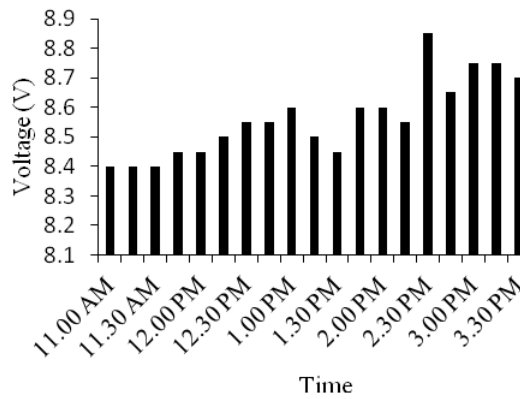

**Fig. 4.** Variation of voltage with time

Figure 5 illustrates the variation of current of solar panel with time of the day. The current of solar panel shows non uniform trends due to solar intensity variation over the day. It is seen that the current is increased for the same radiation intensity. The maximum current is found is 0.51A at 1 and 2 pm of the day which is reasonable to charge the battery.

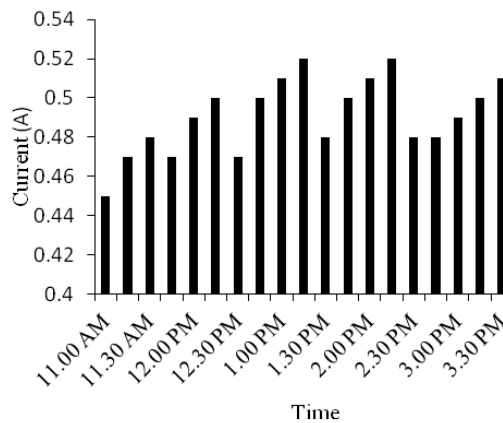

**Fig. 5.** Variation of current with time

Figure 6 shows the variation of power output using solar panel with time of the day. From the figure it is seen that the power output almost similar average of above 3.5W which is reasonable to run the vehicle constructed in this study. Though, the current and voltage are not shown in the same trends. This power constantly applies to the car through battery.

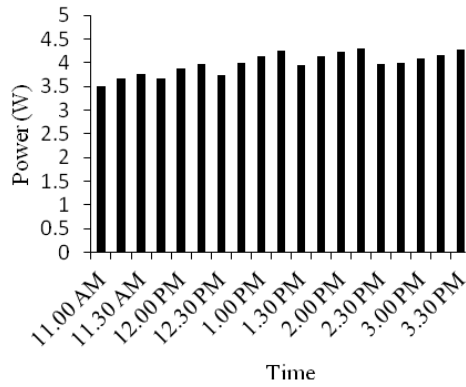

**Fig. 6.** Variation of power with time

### 3.2 Vehicle running performance

Figure 7 illustrates the variation of vehicle velocity with applied load. From the figure it is seen that, the Vehicle velocity decreases with increasing applied load. At the design load 2 kg the vehicle velocity is found to 1.87 km/h. The applied load should not increase too high and it considered near or below the design value to keep the equipment performance well. The experimental vehicle velocity (1.87 km/h) is deviate from the design vehicle velocity (4.89 km/h) due to the fact that the weight of the final vehicle was not in the range of design value. Few unnecessary materials were added in the vehicle system that makes the system heavy. After all the system is a prototype and the principle could be applied in the vehicle manufacturing sector in home and abroad using the solar panel.

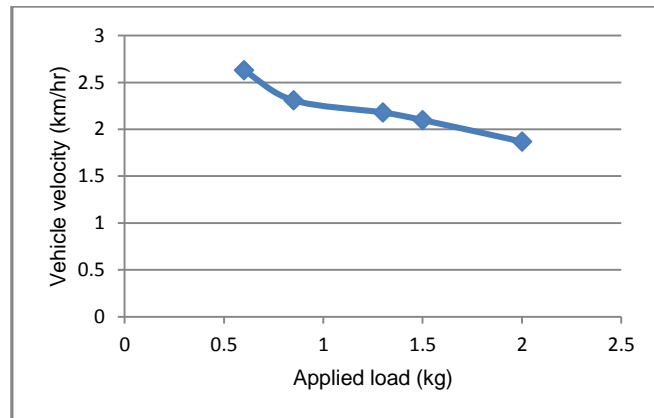

**Fig.7.** Variation of vehicle velocity with applied load

### 4. Conclusions

Design, construction and performance test of a solar powered prototype vehicle were conducted in this study. The results showed that the vehicle is successfully able to run near about 1.87 km/h for the applied load of 2 kg. The vehicle is constructed using locally available materials in Bangladesh. Hence, experimental performance is useful for future reference and for construction the heavy vehicle in the manufacture industry. This study is useful to encourage the manufacturer in home and abroad to reduce the energy crisis now and in future. It also helps to reduce the GHG emission in the atmosphere.

### Acknowledgement

Author would like to thank the Rajshahi University of Engineering & Technology to provide the appropriate platform to conduct the study. Thanks are also extended to Md. Shamsuzzoha Sarker and Md. Jahid Mahabub in the department of Mechanical Engineering for keep effort in this study.

## References

- [1] J. Dargay, D. Gately and M. Sommer, 'Vehicle Ownership and Income Growth, Worldwide: 1960-2030', *The Energy Journal*, v. 28, no. 4, pp. 143-170, 2007.
- [2] L. David, Greene 'Future Prices and Availability of Transport Fuels', International Transport Forum, Joint Transport Research Centre (OECD), paper no. 2007-15, 2007.
- [3] D. Pimentel, 'Renewable Energy: Economic and Environmental Issues'. <http://dieoff.org/page84.htm>
- [4] B. Rath, 'Power from sunlight: Photovoltaics'.  
<http://asmcommunity.asminternational.org/static/Static%20Files/IP/Magazine/AMP/V165/I05/amp16505p062.pdf?authtoken=153bded8b5a280f198db66d55762f8e86ed134df>
- [5] P. Rudra, R. Andry, 'Introduction to static and dynamics' Chapter 1-10, spring 2001.
- [6] R. K. Bansal, 'A text book of engineering mechanics'.
- [7] R. S. Khurmi, 'A text book of Engineering Mechanics'.

## Diversification of Rural Energy Consumption Pattern in Bangladesh: A Case Study

P. K. Halder<sup>1</sup>, N. Paul<sup>2</sup>, Sabrin Arefin<sup>1</sup>, K. M. Razwan Kabir<sup>1</sup>, M. R. A. Beg<sup>3</sup>

<sup>1</sup>Department of Industrial and Production Engineering, Jessore University of Science and Technology, Jessore-7408, Bangladesh

<sup>2</sup>Institute of Appropriate Technology, Bangladesh University Engineering and Technology, Dhaka-1000, Bangladesh

<sup>3</sup>Department of Mechanical Engineering, Rajshahi University Engineering and Technology, Rajshahi-6204, Bangladesh  
E-mail: pobitra.halder@gmail.com

### Abstract

*Bangladesh is a developing country where rural energy need is one of the major threats for the country's economic development. This paper explores the energy accessibility and consumption pattern in a selected rural area in Bangladesh. Cooking and lighting are the major sectors for energy demand met by traditional energy sources. Biomass, primarily agricultural waste, cow dung, wood, and tree leaves covers the cooking energy demand. On the other hand, kerosene is the foremost commercial energy source for illuminating the area. Considering their environmental threats government of Bangladesh is focusing on renewable and environmentally sustainable technologies. The paper also illustrates the willingness of the villagers to pay for these technologies. Some of the villagers have already established domestic biogas plant and solar home system and enjoying better lighting and cooking facility.*

**Keywords:** Energy access, biomass energy, renewable energy, poverty, cooking and lighting.

### 1. Introduction

Bangladesh is one of the low energy consumption countries in the world with an area of 147570 sq. km. Total population of the country is about 164 million of which almost 70% live in rural areas. As a developing country, sufficient modern energy is crucial for the economic and health issues for the country. However, per capita primary energy consumption rate in the country is still very low as accounts 205 kg oil equivalent [1]. In Bangladesh, about 60% of the total population has electricity access and only about 1.5 million households have natural gas connection for their energy need [2]. Moreover, almost 90% households in Bangladesh use biomass and rest use natural gas, LPG and biogas for cooking [3]. Only, straw, leaf and dried cow dung contributes about 51.20% of total cooking fuel and kerosene contributes almost 39.50% of total lighting energy in Bangladesh [4]. Household energy consumption is closely related with the economy and living standard of the country. However, there is huge gap between energy demand and supply in Bangladesh and this unsatisfied energy demand impedes the country's progress towards the vision 2021. This scenario is in acute stage in the rural areas where the people have no modern energy access. Only 20% of the people living those rural isolated areas in Bangladesh enjoy electricity facility. In addition, they have no gas connection yet. Bangladesh is a poor country where almost 53 million people live below the poverty line although the poverty declined by 19% during the last decade-and-a-half [5]. Therefore, people in rural areas lead a vulnerable life and unable to utilize commercial energy due to its higher price. Biomass resources such as wood, bamboo, twigs, wood shavings, sawdust, bark, roots, shell and coir of coconut, agricultural residues (paddy husk and bran, straw, jute stick) charcoal and cow dung are the main cooking energy sources used by almost 99% households in rural areas. On the other hand, kerosene and candle are the major sources used for lighting purpose. In this modern era, biomass is still the leading energy source in rural areas in Bangladesh due to poverty, lack of resources and effective energy policies. Traditional use of these biomass energy and kerosene causes hazard effects on user health and responsible for air pollution. Thus, rural people are willing to pay for switching to alternative clean energy sources like small scale biogas plant, solar home system etc. Government has already taken several initiatives to disseminate these technologies throughout the rural areas. Grammen Shakti, BRAC, RSF, Shrizony Bangladesh are the pioneer private organizations establishing these technologies to improve life standard and better health of rural populations. Moreover, the technologies are getting momentum and acceptance in rural areas. This paper

presents a privileged survey of a selected village namely, Abdulpur in Churamonkati union in Jessore district, Bangladesh. The paper also shows the socio-economic status as well as energy need and consumption pattern of the villagers of that rural area.

## 2. Survey area and methodology

A village named Abdulpur in Churamonkati union in Jessore district, Bangladesh was selected for the survey as shown in Fig. 1. Total households surveyed in the village are 59 of which 28 households are utilizing renewable and green technology. The total number of the inhabitants in the households surveyed is 312 of which 153 are accessing renewable energy with average family size of 5-6 persons per household.

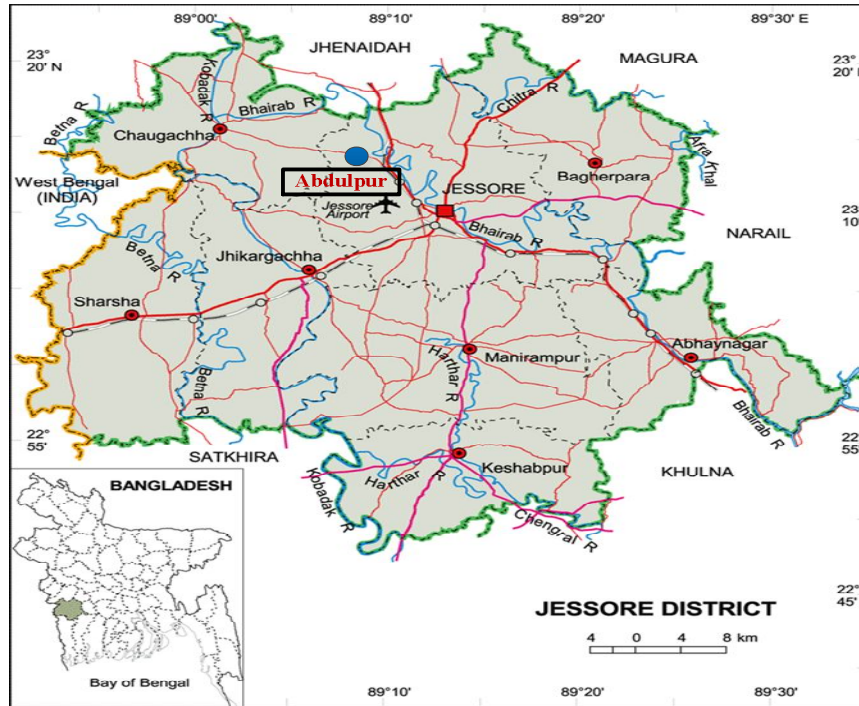

Fig.1: Geographic location of survey area

More than 75% of the respondents are educated in the village where 35.71% of them have at least higher secondary education and rest have primary and secondary education. Most of the households (almost 82%) in the village have very low and medium monthly income which indicates the poor economic situation of the village. About 25% of total households depend on agriculture as their primary income source whether almost 67.86% depend as secondary income source. All the data including socio-economic condition and energy need are collected from the peoples of the village through a comprehensive series of questionnaire. The whole procedure of this work is presented in Fig. 2.

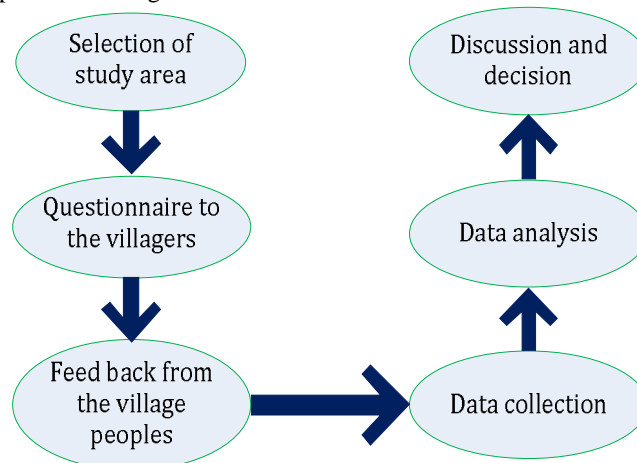

Fig. 2: Schematic representation of methodology

### 3. Energy status in survey area

#### 3.1. Energy access ability

The villagers use cow dung cake, cow dung stick, jute stick and tree leaves for cooking purpose. Generally, they collect these biomass fuels from agricultural land, domestic cattle and trees around the house. On the other hand, lighting fuel kerosene is collected from nearby hat, bazar or market. However, the fuel collection is not easier for the villagers all the time as it depends on income, collection time and available own resources. Figure 3 represents the degree of fuel access of villagers depending on their income. About 40% of low income people collect easily from the field and other sources whether 45% of them found sometime difficult to collect as they have no enough money to buy or enough cattle for dung or enough agricultural land for residues. On the other hand, medium and high income group shows the higher percentage of easy collection for their available own resources like cattle, land and money. Nevertheless, high income group faces problem for collection due to lack of sufficient members or time.

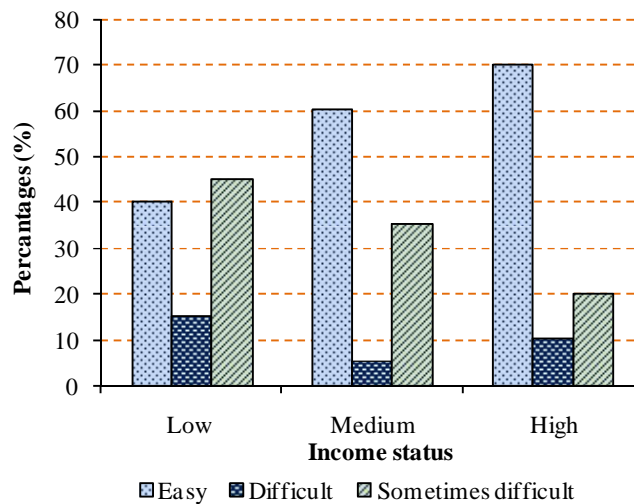

Figure 3: Fuel accessibility of various income groups in selected village

#### 3.2. Reasons to change the energy consumption pattern

Now-a-days modern energy supply is the key indicator of industrial development as well as to change the lifestyle of human being in the world. As a part of digital Bangladesh the rural people of the country are intending to shift their energy consumption pattern into modern energy like solar, biogas etc. The primary energy consumption in survey area includes kerosene and biomass (wood, crop, dung) for lighting and cooking.

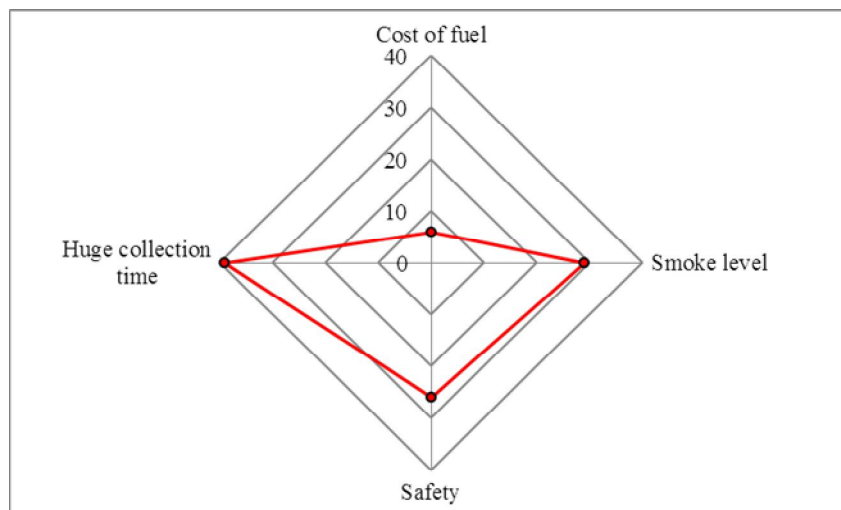

Fig. 4: Reasons for changing the current cooking pattern



## Experimental Investigation of a Hybrid Evacuated Tube Solar Collector

J Ferdous<sup>1</sup>, R A Beg<sup>1</sup> and M R I Sarker<sup>1</sup>

<sup>1</sup>Department of Mechanical Engineering,  
Rajshahi University of Engineering and Technology, Rajshahi-6204  
E-mail: jfe092016@gmail.com

### Abstract

*This paper presents the design, construction and experimental study of a hybrid type evacuated tube solar collector. This evacuated tube solar collector is engaged with an air cooling system to assist in heating the compressed working fluid using solar energy. This process reduces the compressor power and so the annual electric bill consumption by an air cooler will also reduce ultimately. In this study, an evacuated tube solar collector was constructed and experimentally tested. Copper made evacuated tubes and an insulated flat plate collector was used to construct this hybrid evacuated tube solar collector. Methanol was used as a heat transfer fluid. It was passed through the heat pipe to carry the absorbed solar energy. The results obtained from the experimental investigation show that the thermal efficiency of the collector was 29.17%. The energy obtained from the collector is capable to reduce the compressor power of the air cooling system and results in an improving in the whole system efficiency.*

**Keywords:** Solar collector, Evacuated tube, Methanol.

### 1. Introduction

One of the promising sources for diminishing energy crisis is to make more extensive use of non conventional source of energy derived from the sun. It is known to us that renewable energy source is available in amount throughout the world in adequate quantity and of cost. Owing to increasing need for renewable energy sources, the investment for solar collectors' use is growing day by day. Recently evacuated tube collectors are most extensively used device to convert solar radiation into heat. Miscellaneous working fluids (methanol, ethanol, acetone etc) can be used in the heat pipe and varying results can be obtained for each.

The main motivation behind this concept came from ideas of evacuated tube solar collector as a novelty of this thought in our country. Several countries in the world are now enjoying the blessings of solar energy by utilizing it in reduction of electrical energy consumed by electrical machines. Some of the companies developing evacuated tube solar collectors are Apricus [1], SunMaxx [2] and Northern Lights [3] etc. These collectors are available in a range of sizes. The heart of the evacuated tube solar collector is heat pipe. A heat pipe can be considered as an evaporating and condensing device for rapid heat transfer. An evaporating-condensing cycle is employed by the heat pipe collecting heat from an external source. This external heat source increases liquid to its boiling point. A water based liquid in the heat pipe absorbs its latent heat of vaporization when sun rays fall on it. The liquid releases its latent heat of vaporization in the condenser region when it comes into contact with the flowing liquid through the header. In this way the latent heat of vaporization is transferred. This process is repeated continuously by a gravity return feed mechanism of the condensed fluid back to the heating zone [4].

Both the radiative and convective losses are suppressed by the selective surface and vacuum inside of the heat pipe. Loss of vacuum is only at the side of a glass-to-metal permanent seal or an all-glass seal. Even if vacuum is lost, in a few of many tubes, performance of the entire collector decreases slightly. It is fully protected from oxidization, moisture, or any other form of attack as the black coating is inside the evacuated space in all designs. The glass tubes design are simple [5]. Evacuated tube collectors normally have a smaller fraction of total occupied area actually intercepting solar radiation compared with the most flat plate designs. Spacing between tubes, areas required for manifolds, and piping access all require space, which limits coverage by solar absorbing surface [5]. In traditional applications they can provide a means for utilizing solar energy for domestic hot water or space heating, air conditioning, thermal driven cooling and industrial process heating applications. The main advantage of evacuated tube solar collector is to use it with an air cooler [6].

The prominent objective of this study is to enhance the performance of a general purpose air cooler when combining with a vacuum tube solar collector that is installed after the compressor. Solar air cooler is perhaps the most powerful development in solar vacuum tube technology. The solar thermal energy is collected in a

device called solar collector. It consists of a dark coated surface called absorber, fluid flowing header contained in manifold and suitable protections for heat loss reduction, generally vacuum in this case. When exposed to the sun, the absorber absorbs the solar radiation and transfer a part of it to the fluid flowing through it. Vacuum tube collectors provide high temperature difference than the general flat plate solar collector and thus help to make it efficient solar air cooler systems.

## 2. Concept of a hybrid solar air cooler system

A single-stage vapor compression solar air-cooler consists of six major components, namely a compressor, a condenser, an expansion device, an evaporator, a solar vacuum collector and a solar storage tank. Fig.1 shows schematic block diagram of a solar air cooler system. The cycle starts with a mixture of liquid and vapor refrigerant entering the evaporator. The heat from warmed fluid collected from the solar collector is absorbed by the evaporator coil. During this process, the state of the refrigerant is changed from a liquid to a gas and becomes superheated at the evaporator exit. The superheated vapor then enters the compressor where a rising pressure will in turn increase the temperature. A vacuum solar panel installed after the compressor, uses solar radiations as a heat source to warm up the water. An insulated water storage tank is connected to the vacuum solar collector to maintain the water temperature. Therefore, the vacuum solar collector reheats the refrigerant to reach the necessary superheat temperature in order to reduce the required electrical energy to run the compressor. A valve is installed after the compressor to regulate the refrigerant mass flow rate. The refrigerant from the compressor goes through the copper coil inside the tank where a heat exchange is undertaken. From the storage tank the refrigerant then passes through the condenser and turns into liquid by rejecting latent heat. The liquid refrigerant then passes through capillary tube or expansion valve and its pressure and temperature is reduced and the refrigerant then enters into the evaporator for repeating the cycle [7].

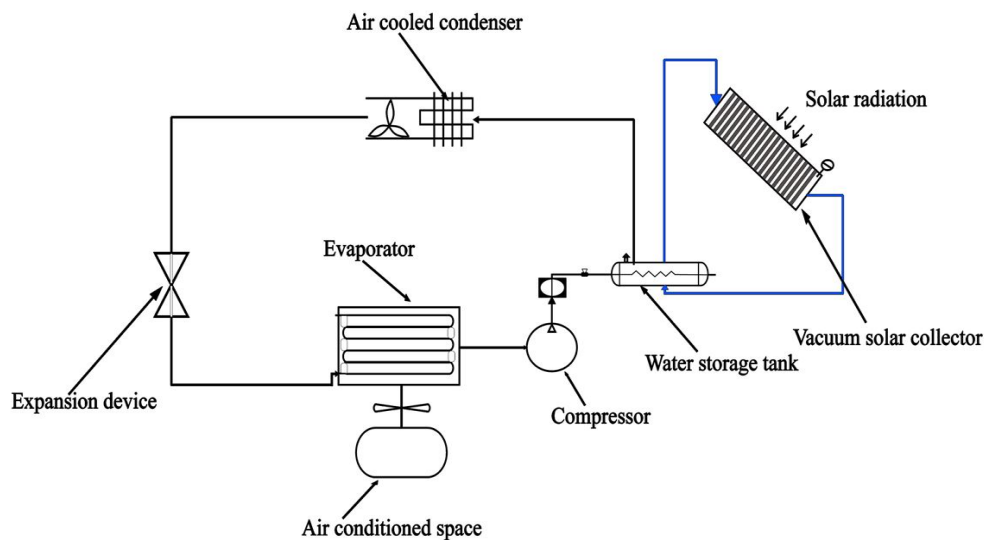
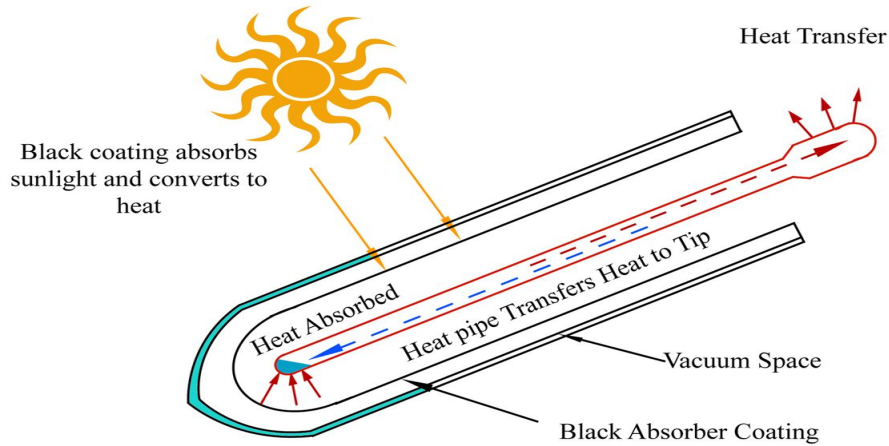

Fig. 1. Schematic block diagram of a solar air cooler system

## 3. Experimental setup

A vacuum tube solar collector consists of four main components. They are evacuated tube, heat pipe and copper header with manifold. Evacuated tubes are generally U shaped. A black paint coated copper tube heat pipe was used which was surrounded with a U shaped evacuated glass tube to vacuum it as required. For greater thermal efficiency low emissivity borosilicate glass tubes are used and black paint on the tube was used to enhance the solar energy absorption capacity [8]. The copper header pipe was situated in the insulated box called manifold. An aluminum casing was used to make a manifold. To reduce total roof loading in larger installation and for ease of installation, light weight of the manifold is important. In order to withstand the temperature of up to 482<sup>0</sup>F the manifold was packed with glass wool insulation and is sealed with silicone rubber. An evacuated tube is shown in Fig. 2.



**Fig. 2.** Evacuated tube

Selection of working fluid is directly related to the properties of the working fluid. The properties are going to affect both the ability to transfer heat and the comparability with the case [9]. Table 1 represents some important properties of different working fluid which is commonly used in an evacuated tube collector [10].

**Table 1.** Properties of commonly used working fluid in a evacuated tube solar collector

Working Fluid	Melting Point, K at 1 atm	Boiling Point, K at 1 atm	Useful Range, K	Compatible Material
Freon 22	113.1	232.2	193-297	Aluminum
Freon 21	138.1	282.0	233-360	Aluminum, Iron
Freon 11	162.1	296.8	233-393	Aluminum
Freon 113	236.5	320.8	263-373	Aluminum
Acetone	180.0	329.4	273-393	Steel, Copper, Brass, Silica
Methanol	175.1	337.8	283-403	Copper, Brass, Silica, Nickel
Water	273.1	373.1	303-550	Stainless steel, Copper, Silica, Nickel, Titanium

Considering the favorable boiling and freezing point compatibility with the designed heat pipe material and availability, methanol was primarily chosen for the current solar collector. Table 2 shows physical properties of pure methanol [11].

**Table 2.** Physical properties of pure methanol

Properties	Value
Boiling Point (101.3 kPa)	337.75 K
Freezing Point	175.55 K
Latent heat of vaporization at 298.15 K	37.43 kJ mol <sup>-1</sup>
337.75 K	35.21 kJ mol <sup>-1</sup>

The various components of the current solar collector with the dimensions were presented in Fig. 3. For the construction of a hybrid evacuated tube solar collector, four glass tubes were used with a center drilled hole on the top glass cover. In a folded 0.375" copper pipe, methanol was injected which was used as the working fluid. Then four holes were drilled on the 1" copper header pipe. A 0.5" copper pipe as condensing unit was connected between the heat pipe and the header manifold. Vacuum pump and pressure gauge was used for making vacuum within the copper tube. -24 kPa vacuum pressures were maintained inside the heat pipe. Performance test of the solar collector was carried out placing the solar collector in a sunny place where average solar intensity 1000 W/m<sup>2</sup>. Then, water was supplied through one end of the header in order to have the temperature difference for calculating solar collector's efficiency. The inlet and outlet temperature of the water was measured using a proper ranged thermometer. Mass flow rate was measured using a 100 ml measuring cylinder. The outlet water

temperature was recorded after half an hour interval during the whole experimental interval of a sun shine day. Temperature was recorded changing the mass flow rate at different interval of a definite sun shine day. Fig. 4(a) and 4(b) shows the schematic of the experimental solar collector setup and the photograph of the solar collector's construction respectively.

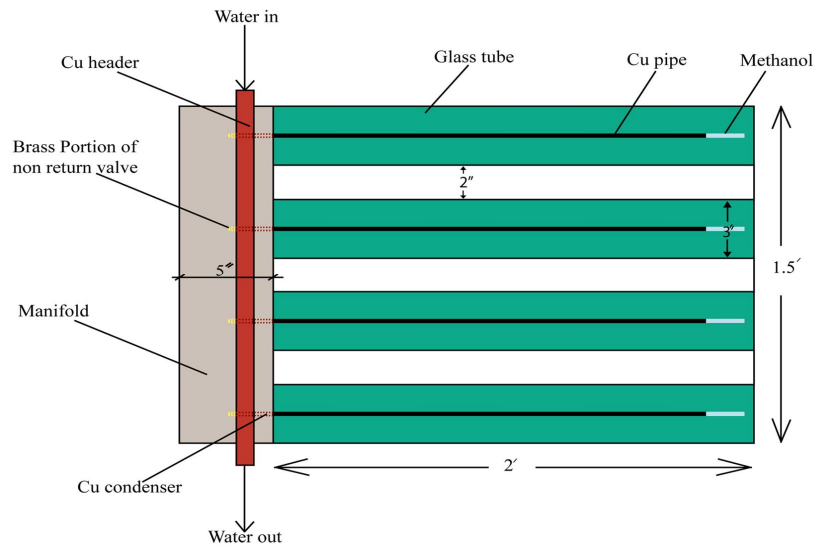

**Fig. 3.** Design of the hybrid evacuated tube solar collector

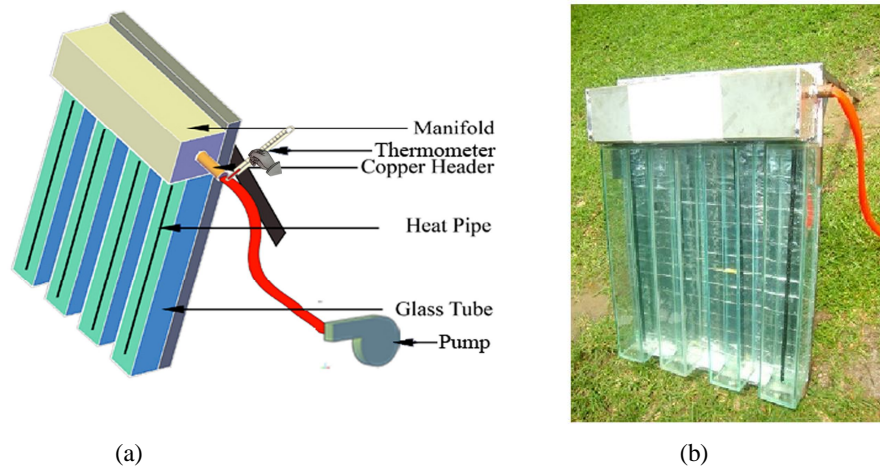

**Fig. 4.** (a) Schematic of the experimental solar collector setup (b) Photograph of the constructed solar collector

#### 4. Results and Discussions

Solar intensity and mass flow rate of water are the two important factors upon which the efficiency of a solar collector depends on. Hence, experimental analysis was carried out by varying the mass flow rate of water in the range of 0.00189 -0.00208 kg/s and at different sun shine hour. Fig. 5(a) and 5(b) represents the temperature and efficiency variation of the collector with day time. In Fig. 5(a) it is seen that the temperature difference increases with time up to 1.30 PM and after that it decreases. At day 4, the minimum and maximum temperature difference was 11K at 11.00 AM and 13.6K at 12PM respectively for the mass flow rate of 0.0189 kg/s. It is seen that all the curves are parabolic in nature. The reason of parabolic shape is the increase of sunshine intensity till 1.30PM and its simultaneous decrease after the period 1.30PM.

The thermal efficiency of a solar receiver is another important parameter in evaluating its performance, which is defined as the ratio of the heat carried out by the working medium over the incident solar power. It is expressed as follows:

$$\eta_{th} = \frac{\dot{m}c_p(T_o - T_i)}{Q_{solar}} \quad (1)$$

Here,  $c_p$  is the specific heat of the heat transfer medium,  $T_i$  and  $T_o$  indicate the inlet and outlet temperature,  $\dot{m}$  is the total mass flow rate of the working medium i.e. air for this analysis and  $Q_{solar}$  is the input solar power through the quartz window aperture of the receiver. Variation of the thermal efficiency (Fig. 5(b)) of the collector was shown the similar tendency like the temperature variation with day time. This intermittent nature is a problem for solar energy. Hence, a storage system can be added to solve the problem of constant power supply to the cooling system throughout the day.

Fig. 6 shows that, the outlet water temperature reduces with an increase in the water flow rate. The temperature of the outlet air was 13.6K higher at a mass flow rate of 0.00189kg/s and that was 13.5K for 0.00208kg/sec (Fig. 6). The reason behind this phenomenon was the increase of water temperature with the expense of absorbed solar energy by the collector. As the mass flow rate increases, large amount of water flows through the header and so more heat is taken away by the water. As a result the temperature was decreased with increasing the mass flow rate of water.

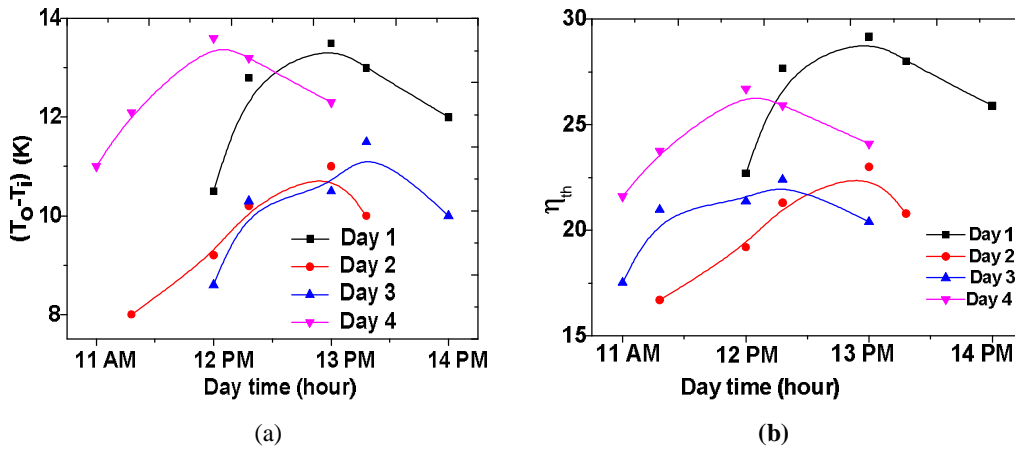

**Fig. 5.** (a) Variation of temperature difference ( $T_o - T_i$ ) between the inlet and outlet air with the day time  
(b) Variation of thermal efficiency between the inlet and outlet air with the day time

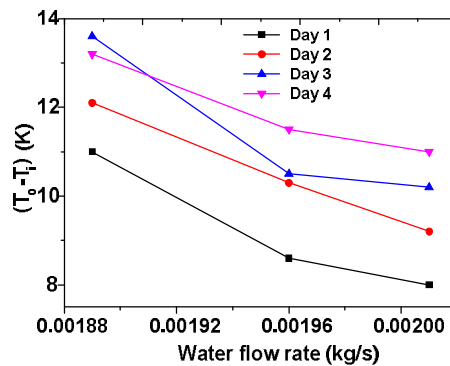

**Fig. 6.** Variation of temperature difference ( $T_o - T_i$ ) between the inlet and outlet air with the mass flow rate of water

## 5. Conclusion

In order to engage with an air cooling system, an evacuated tube solar collector is designed and constructed with an absorber area of 0.3675 m<sup>2</sup>. In addition, the performance analysis was carried out through an experimental investigation. Experiments showed that the maximum and minimum outlet temperature difference was 10.5K at a mass flow rate 0.00189 kg/s and 13.5 K at a mass flow rate of 0.00208 kg/s a specific day. Also for a constant mass flow rate of 0.00189kg/s, the temperature difference increases at 13.6K at 12.00 PM and it was 11K at 11PM. The maximum obtained efficiency of the collector in this paper is 29.17% for mass the flow rate of 0.00208 Kg/s. The addition of this collector was able to reduce the power consumption of the evacuated compressor as the collector was added an additional 29% energy into the system. Hence, it helps to reduce the use of the conventional power in the system.

## References:

- [1] Apricus Solar Hot Water, "Evacuated Tube Solar Collectors". Available from: [http://www.apricus.com/html/solar\\_collector.htm#.VcdZWLvhbW0](http://www.apricus.com/html/solar_collector.htm#.VcdZWLvhbW0)>.
- [2] SunMaxx Solar Hot Water Solution, "Solar Hot Water & Heating Manufacturer". Available from: <http://www.sunmaxxsolar.com/evacuated-tube-solar-collectors.php>>.
- [3] Northern Lights Solar Solutions, "Solar Evacuated Vacuum Tubes". Available from: < <http://www.solartubs.com/solar-evacuated-tube.html>>.
- [4] Dr. F. Mahjouri, "Vacuum Tube Liquid-Vapor (Heat Pipe) Collectors", Thermo Technologies, June 20, 2012.
- [5] Dr. Eng. Mohammed M. El-Khayat, "Heat Pipes: Theory and Operation", Conference on New Energy Technologies for Environmental Development in the Arab World, Cairo, Egypt.
- [6] G. C. Nalamwar, N. R. Kannake, S. S. Sontakke, "Study and Fabrication of Vacuum Tube Collector Solar Water Heater", International Journal of Engineering and Innovative Technology (IJEIT) Volume 2, Issue 1, July 2012.
- [7] Q.P. Ha and V. Vakiloroyaya, "A novel solar-assisted air-conditioner system for energy savings with performance enhancement", Evolving Energy-IEF International Energy Congress (IEF-IEC2012), July 30, 2012.
- [8] Solar Panels Plus, "Evacuated Tube Solar Water Heating Collectors", Solar Water Heaters - Commercial Applications. Available from: < <http://www.solarpanelsplus.com/evacuated-tube-collectors/>>, 2014.
- [9] Per Wallin, "Heat Pipe, selection of working fluid", Project Report MVK160 Heat and Mass Transfer, May 7, 2012.
- [10] Thermal-FluidsPedia, "Working Fluids and Temperature Ranges of Heat Pipes", Thermal Fluids Central. Available from:<[http://www.thermalfluidscentral.org/encyclopedia/index.php/Working\\_Fluids\\_and\\_Temperature\\_Ranges\\_of\\_Heat\\_Pipes](http://www.thermalfluidscentral.org/encyclopedia/index.php/Working_Fluids_and_Temperature_Ranges_of_Heat_Pipes)>, 13 March 2014.
- [11] Physical Properties of Pure Methanol. Available from: <<http://www.methanol.org/TechnicalInformation/Resources/Technical-Information/Physical-Properties-of-Pure-Methanol.aspx>>.

## Maximum Utilization of Solar Radiation in a Solar Air Heater Combined with Solar Cells by Concave Lens

Md. Sazan Rahman\*, Md. Saiful Islam, Najmul Hoque, Mohd. Rafiqul Alam Beg  
Department of Mechanical Engineering, Rajshahi University of Engineering & Technology  
E-mail: sazan.ruet@gmail.com

### Abstract

*A solar hybrid energy system having photovoltaic and thermal (PV/T) devices, which produces both thermal and electrical energies simultaneously is considered for this study. A double pass hybrid solar air (PV/T) heater with concave lens is designed and fabricated to observe its thermal and electrical performance. The collector is designed in such a way so that it contains concave lens which diverse sun light from collector plate to solar panel. The raise in temperature of the solar cell is liable to decrease its electrical performance and that is why the temperature above the solar panel is maintained around 25°C by diverging light through concave lens to obtain maximum electrical power. Less space required for lens compared to normal systems also yield a better thermal power. The system produces overall efficiency 52.66% at mass flow rate 0.02816 kg/sec whereas the maximum thermal and electrical efficiency was 52.5% and 3.85% accordingly. Around 9.24% efficiency improvement has been achieved due to the design improvement for this study.*

Keywords: Solar radiation, air heater, solar cell, concave lens.

### 1. Introduction

Solar energy is one of the most important sources of clean energy. Solar thermal energy systems convert solar energy into heat whereas solar photovoltaic systems produce electrical energy. Besides, in solar thermal energy systems electrical energy is one of the inputs for extracting the useful energy. A hybrid PV/T collector, however, provides both thermal and electrical energy simultaneously. This concept increases the electrical efficiency of photovoltaic systems by decreasing cell surface temperature and increasing overall efficiency of the hybrid unit.

A number of theoretical, numerical and experimental studies have been reported on the solar Hybrid PV/T air collector using air or water as the working fluid. Integrated PV/T collector based energy system produce both thermal energy and electrical energy, Kern and Russel [1]. Thermal efficiency and other performances of different types of collectors and unglazed transpired collector have been analyzed by M. Augustus Leon and S. Kumar [2]. But the transpired collector is not available everywhere. The flat plate heaters can absorb both direct and diffuse solar radiation while The concentrating heaters in the main can absorb only direct solar radiation The flat plate solar collector, its heat flow paths, way of losses have been reported, Fabio Struckmann [3]. In which the reflection (10%) and absorption (5%) loss of glass cover and the collector plate reflection (5%) loss etc are shown. So heat absorbed by the collector is 80%. But most of which i.e about 45% heat is lost to surrounding due to poor insulation. So most solar collectors have maximum thermal efficiency 35%. By proper designing if any of these factors can be minimized then higher thermal efficiency can be obtained. The efficiencies for varying mass flow rate have been reported by Omjara and Aldabbagh and they observe the efficiency increases with increasing mass flow rate where external electrical source is needed [4]. The thermal efficiency increases with increase in height and number of fins of a double pass flat plate solar air heater with longitudinal fins, whereas the entropy generation was inversely proportional to the height and number of fins, Naphon [5].

Heating of both air and water simultaneously with electricity have been offered a complicated design but gives maximum efficiency 65% which required expensive transparent cell, Musallam Ahmed Tabook *et al* [6]. The combined PV/T system have been designed where the solar panels are placed above the collector surface. Panel is cooled by air flow above the collector surface which also act as air heating system but a large fraction of collector exposed area is covered by solar panel that have been found as major limitation, Maruful Haque and Md. Sharif Ahsan [7]. From those above study, in order to overcome maximum limitations, difficulties, and complexities and by considering maximum efficiency with lowest cost, a new design of PV/T collector is installed in this project and its performances are analyzed and compared with previous set up.

In this project, a simple flat plate collector is used to collect solar radiation because the concentrating heaters in the main can absorb only direct solar radiation while the flat plate heaters can absorb both direct and diffuse solar radiation. Black paint is used to make it a black body. Because black paint has reflectivity 0.02 & absorptivity 0.99. The collector contains 8 concave lenses where each 2 lens is used for one solar panel of 5 watt rated. In all previous set up, the solar panel is placed on the surface of the collector. So, a large area of black body is covered by solar panel & large amount of air is required to keep it's temp. at around 25°C at which it gives maximum efficiency. But by replacing solar panel by lens, a large advantage is obtained. When light is refracted through the lens and falls on the panel surfaces, due to small area of lens & more area of collector exposed to sun light & due to its diverging effect, the temp above the solar panel is lower than normal sun light temperature. The solar panel cooling is done by natural flow of atmospheric air.

Here, the light above the cell is not properly maintained that is why the cell gives lower output than it's rated value. But due to large area utilization, the collector gives maximum output or more efficiency than all previous set up. The latest set up gives 26.8% overall efficiency without fin [6]. But this project gives more collector & overall efficiency than previous set up i.e about 52.5% and 52.66% respectively.

## 2. Methodology

The solar air heater of modified setup has been designed which is shown in figure 1. The materials used for the design are mainly: Wooden box : (1.5×1×.12) m<sup>3</sup> =1 piece, Glass: (1.46×.96×.005) m<sup>3</sup> = 1 piece, Aluminum plate: (1.5×1×.001) m<sup>3</sup>=1 piece, Concave lens : (0.075×0.0575) m<sup>2</sup>=4 piece, Solar cell: (.30×.23)m<sup>2</sup>= 4 piece, Black paint: 1.5 kg, Stand: Angle bar, Cork board: (0.5inch thick) = 2 piece. Area: 1m<sup>2</sup>, Others: Wood, screw, brush, gum etc.

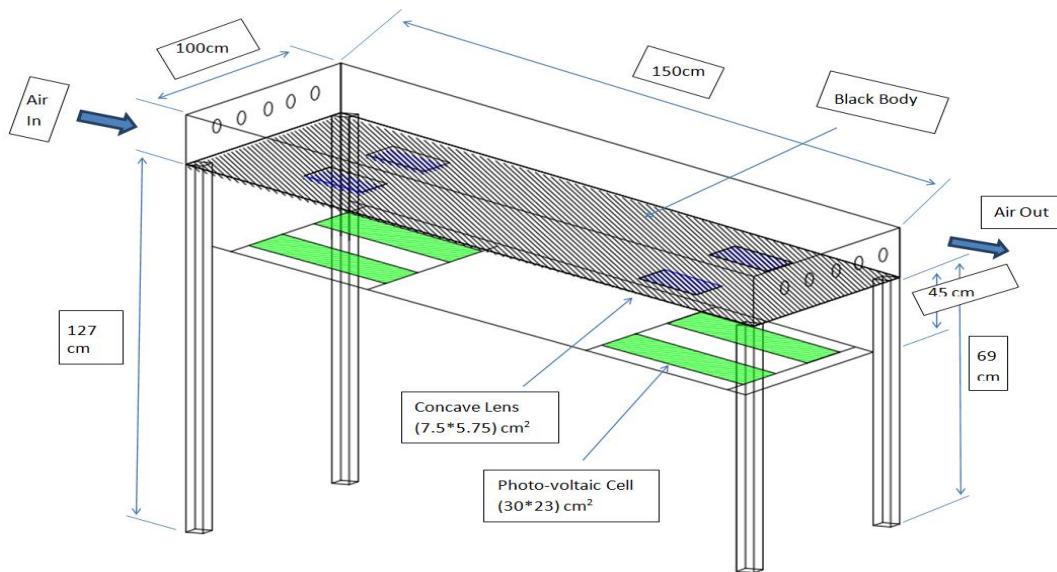

Fig. 1. Isometric view of solar air heater with PV panel

### Construction procedure

At first a wooden box is made whose base is covered by partex of 1.5 m<sup>2</sup>. The box is sufficiently rigid to take the load of cover glass, collector sheet & other arrangements [8-9]. After making the box, the stand is made by angle bar according to the size of the box. In stand, there are two racks that are made to support air heater box & solar panel. Then the box is covered by insulator for which cork sheet of 3 in is used and four opening are cut to pass light through it from lens to the panel which is closed by transparent glass. Next, the G.P. sheet is coated by black paint in order to make it a good radiation absorber and 8 small holes are made to set lens at that opening. After drying the paint, the lens are placed on the sheet opening & adjusted by pudding. Then, this collector sheet with lens is set on the box and total arrangement is covered by transparent glass. After preparing the box, a



convergent section is adjusted with the box which contains both the inlet & exit port for the flowing of air. The exit port also contains the arrangement to hold the blower.

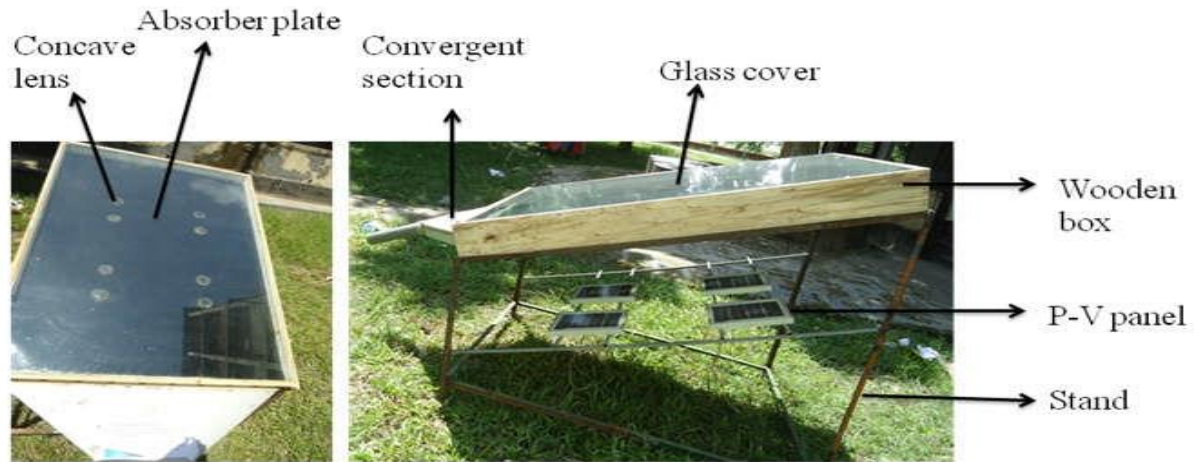

**Fig. 2.** Final assembly of solar air heater

Finally, the box with the convergent section is set on the frame and the solar panels are set on the lower rack according to the lens & the opening of the box. The total system is made incline  $23^{\circ}$  to receive solar radiation in perpendicular with the collector plate.

### **Experimental procedure**

Air inlet and outlet temperatures were measured by using thermometer. From thermometer those data are directly noted to data table with the help of anemometer. The velocity of flow is measured directly from the outlet of the heater [10]. For measuring mass flow rate, the anemometer propeller was placed at the outlet of the blower. The velocity was measured for several times and finally the average velocity was fixed to take reading. The known outlet area was used to calculate mass flow rates according to the formula  $m = \rho Av$  (where,  $\rho$  = density of air,  $A$  = cross sectional area,  $v$  = velocity of air). A rate of mass flow was fixed for a particular day. The velocity was adjusted to keep the mass flow rate constant, since the density of air changes with changes in temperature.

The current and voltage was measured by multi-meter directly. To get the voltage reading the multi-meter is calibrated to voltage part and circuit is connected to voltage knob. Similarly, to get current reading the multi-meter is calibrated to current part and circuit is connected to current knob. From multi-meter those data are directly used to calculate efficiencies. The current and voltage are also measured by changing the circuit in series and parallel. The readings were taken at various intervals (15min, 30min or 60min) and were recorded in a data sheet. The top of the heater was not always placed normal to the sun because the tilt angle of sun varies from time to time but our heater tilt angle is fixed. The day which gives intensity of irregular value was neglected from investigation [11].

### **3. Results and Discussion**

The double pass solar air heater combined with photovoltaic panel by concave lens is investigated experimentally between 08-12-2014 and 17-12-2014 under Rajshahi weather condition. The readings are taken at the bright sunshine day. The performance of double pass solar air heater is studied. The mass flow rate is varied from 0.0012 kg/s to 0.02816 kg/s. where the intermediate mass flow rates are 0.016 kg/s, 0.0181 kg/s, and 0.02112 kg/s. The various curves showing the performance of the solar air heater are given below:

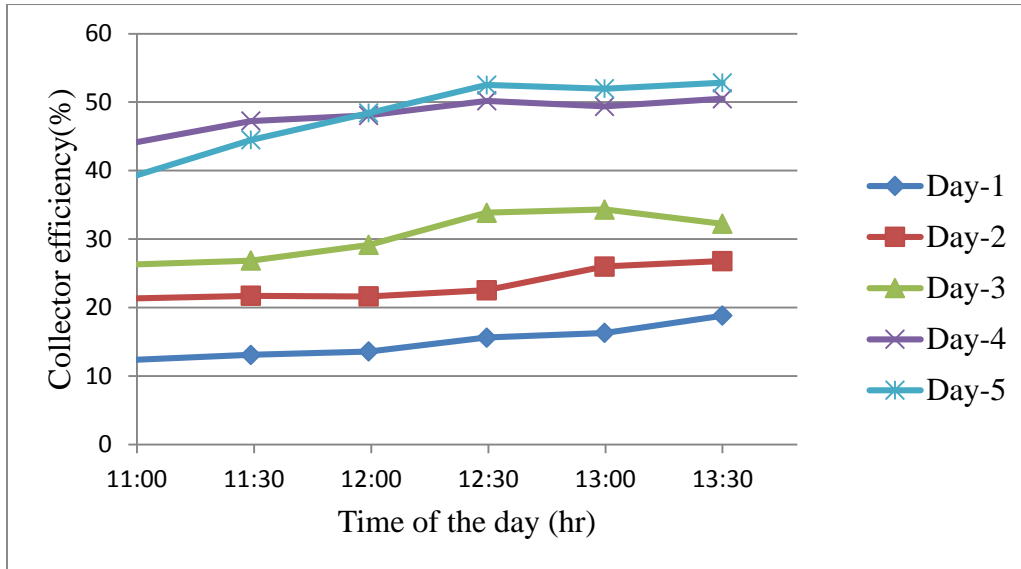

Fig. 3. Time of the day vs. collector efficiency curve.

From fig. 3, it is seen that the collector efficiency increases with the day time. In 1<sup>st</sup> & 2<sup>nd</sup> day, the collector gives lower efficiency due to low mass flow rate and leakage problem. By overcoming the leakage problem and by increasing the mass flow rate, the maximum efficiency of 52.3% is obtained at day-3.

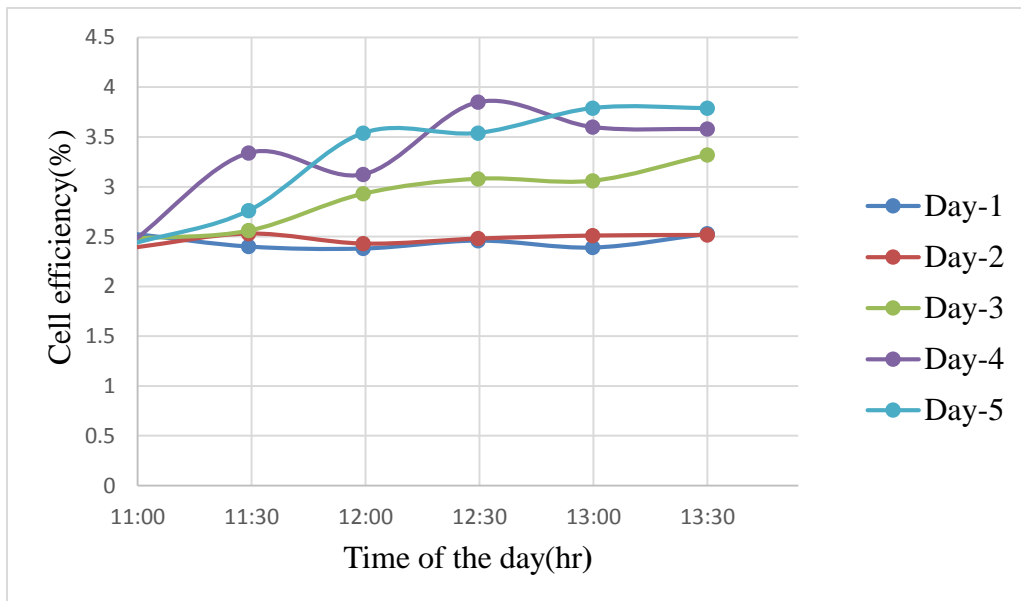
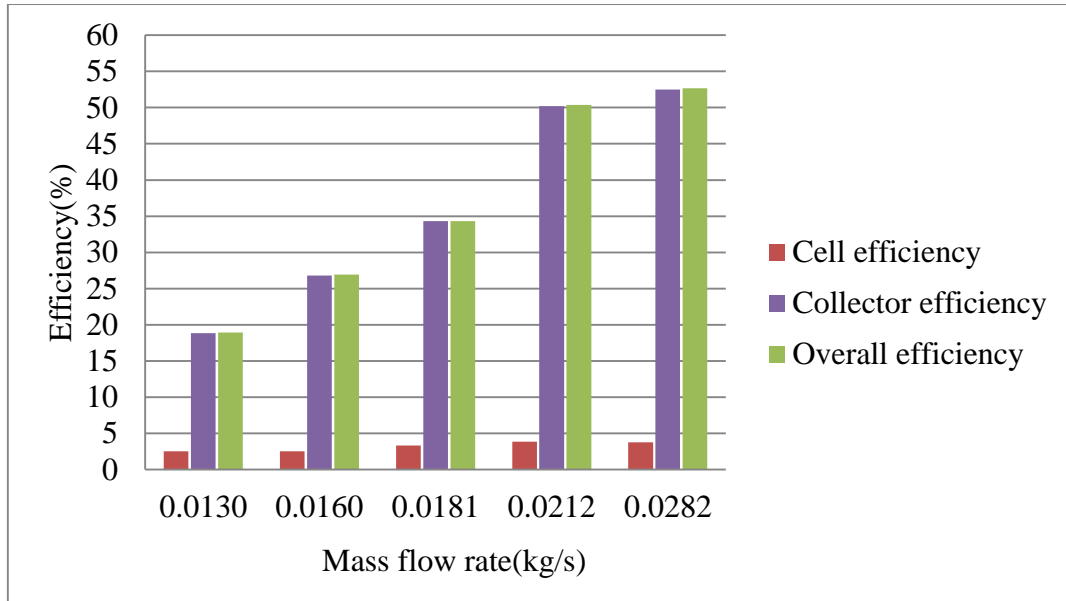

Fig. 4. Time of the day vs. cell efficiency curve.

From fig. 4, it can easily be told that, the cell efficiency is also independent of day time but the efficiency varies slightly due to light angle of the lens. The maximum efficiency is obtained when the solar ray is approached to perpendicular with the concave lens. The cell efficiency varies from 2.38% to 3.85%. The day time and mass flow rate have very little effect on cell efficiency but with increasing the total lighted surface of panel the efficiency will be increased.



**Fig. 5.** Effect of cell efficiency on overall efficiency.

From fig. 5, it is obtained that the effect of cell efficiency is very low on overall efficiency because the cell produce maximum power 2.81 watt with 3.85% efficiency but the collector produce the maximum power 838.08 watt with 52.66% efficiency. So, in order to get maximum overall efficiency, more concentration is given to increase the collector area. By sacrificing small amount of cell power, a large collector power can be achieved for which the overall efficiency of this project is higher than all previous setup.

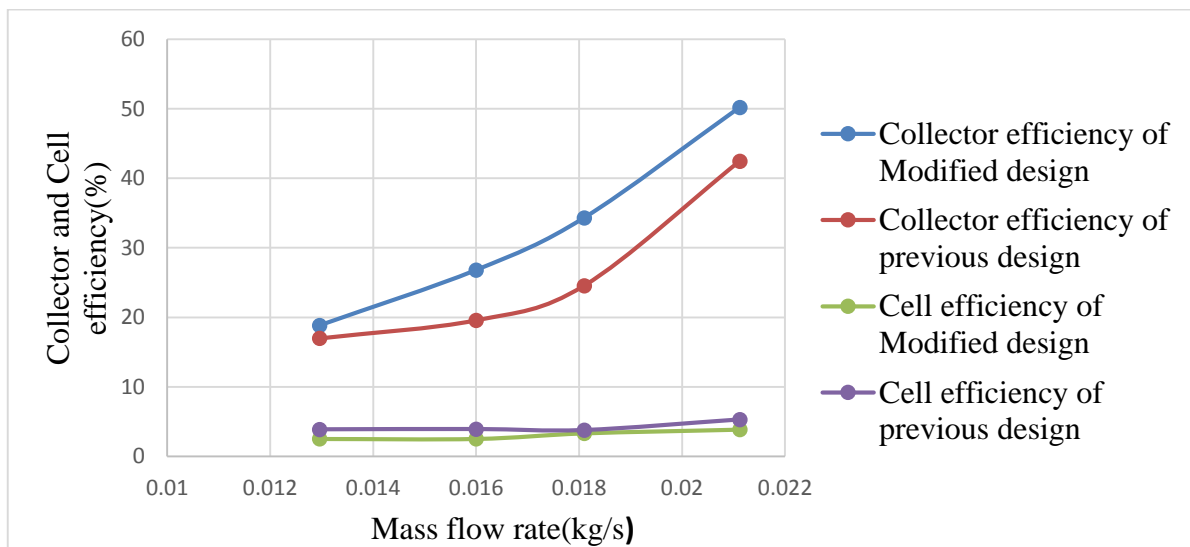

**Fig. 6.** Comparison curve of mass flow rate vs. collector and cell efficiency.

From fig. 6, it is shown that the cell efficiency of modified design is lower than the old design. It is due to poor lighting on panel surface, due to lens angle. If the lens is able to light the whole area of the panel, then the cell gives their rated power and those small power losses is eliminated. But the modified collector gives more efficiency than the old collector which is very much higher than the small lens.

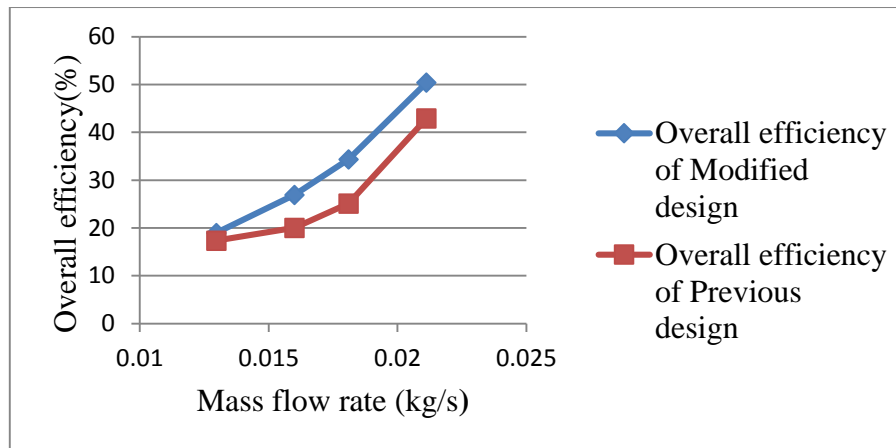

Fig. 7. Comparison curve of mass flow rate vs. overall efficiency.

In fig. 7, it is clear that the overall efficiency of modified design is very higher than the previous. For same mass flow rate of 0.02112 kg/s, the old design efficiency is 42.89% where the new modified design efficiency is 50.38%. So, the improvement in efficiency is 7.49%. As a result, more solar radiation is utilized in modified setup.

#### 4. Conclusion

Hybrid photovoltaic-thermal solar collector is experimentally studied with respect to its operating characteristics. All the data are collected in sunny weather. The thermal efficiency is increased with the increase of mass flow rate. In lower mass flow rate, the efficiency is lower. The mass flow rate varies from 0.01296 kg/s to 0.02816 kg/s. The maximum collector efficiency is 52.50% for the higher mass flow rate of air 0.02816 kg/s. The maximum overall efficiency is obtained 52.66% for the higher mass flow rate of air 0.02816 kg/s. The cell efficiency is also calculated. The maximum Efficiency of cell is 3.85 %.The maximum cell, collector and overall efficiency of previously designed double pass solar air heater are 6.65 %, 42.46% and 42.89% respectively. The maximum improvement of collector efficiency for modification of design is 9.24%. But the maximum humiliation of cell efficiency is 2.8%.

#### 5. References

- [1] Kern Jr, E. C. and Russell, M.C.(1978). "Combined photovoltaic and thermal hybrid collector systems", in: *Proc.13th IEEE photovoltaic specialists*, Washington, USA, 1978, 1153–1157.
- [2] Augustus, L. M. and Kumar,S.\*(2007). "Mathematical modeling and thermal performance analysis of unglazed transpired solar collectors". Received 1 September 2006,*Solar Energy* 81 (2007) 62–75.(Energy field of study , AIT, Thailand .)
- [3] Stackmann, F.(2008). "Analysis of a Flat-plate Solar Collector." Project Report, May 08, 2008, Lund, Sweden.
- [4] Omjara, A.P.O. and Aldabbagh, L.B.Y.(2010). "Experimental performance of single and double pass solar air heater with fins and steel wire mesh as absorber". *Applied energy* 87 (2010) 3759-3765.
- [5] Naphon, P.( 2005). "On the performance and entropy generation of double pass solar air heater with longitudinal fins". *Renewable Energy*. 2005, 30, 1345–1357.
- [6] Tabook1,M.A., Othman2,M.Y., Sopian3, and K. Ruslan4,M.H.( 2014), "A Review Paper on PV/T Combination Flat Plate Collector System and Design" *World Essays Journal* / 1 (1): 1-5.
- [7] Haque,M. and Ahsan, M.S.(2013), "Effect of mass flow rate on the performance of a double pass solar air heater with and without fin". UG thesis, Rajshahi University of Engineering and Technology, Bangladesh.
- [8] Ahmad M. S.(2012). "Modeling of flat plate solar collector operation in transient states". PG thesis, May 2012 Purdue University Fort Wayne, Indiana.
- [9] Ebrahim, M.A.A., Sopian, K., Othman, M.Y.H., and Bin, Y.(2009). "Mathematical model of double pass photovoltaic thermal air collector with fins". *APRN Journal of Engineering and Applied Sciences*. Vol .2, no.5, October.
- [10] Qenawy, A. M. and Mohamad, A. A.(2007). "Analysis of high efficiency solar air heater for cold climates". *2<sup>nd</sup> Canadian Solar Buildings Conference Calgary*, June 10 – 14, 2007.
- [11] Srinivas, M. and Jayaraj, S.(2013). "Energy and exergy analysis of a two pass photovoltaic -thermal (PV/T) air heater". *International journal of Energy and Environment*. Volume 4, Issue 3, 2013 pp.467-480.

## Design & Construction of a Pyrolysis Reactor for Liquid Oil Production from Olive Seeds

M. M. Hassan<sup>1,2\*</sup>, M. Perves<sup>2</sup>, M.J. Alam<sup>2</sup>, Amit Roy<sup>2</sup>, Md. Nurun Nabi<sup>2</sup>

<sup>1</sup>Department of Mechanical Engineering, South Dakota State University, Brookings, SD, USA

<sup>2</sup>Department of Mechanical Engineering, Rajshahi University of Engineering and Technology, Rajshahi-6204, Bangladesh

E-mail: mdmehadi.hassan@jacks.sdstate.edu

### Abstract

*Pyrolysis is one of the most important thermo chemical energy conversion methods for renewable energy sources. Among the various thermal conversion processes, pyrolysis has received much more attention, since the process conditions could be optimized to produce high energy density pyrolysis oils and chemicals. Different types of pyrolysis process have been studied and developed either in laboratory- scale or a pilot plant units and a small number on commercial- scale pyrolysis plants are installed. The results of this research have proved the feasibility of this technology and strongly suggested that Pyrolysis is the most promising technology for solid waste treatment. In this project the stainless steel will be selected for the construction of pyrolysis system and the olive seeds will be selected as feed material. Nitrogen gas will be used to maintain the inert atmosphere in the reactor where the pyrolysis reaction will take place.*

**Keywords:** Pyrolysis, Reactor, Condenser, Olive Seeds

### 1. Introduction

Energy is the basic ingredient of the process of economic development and driving force the global economy. Now a day the standard of living of human being is correlated with per capita energy consumption. The more the energy is consumed, the higher the standard of living is considered. Conventional sources are being depleted at an alarming rate, world will be stopped when the supply of fuel energy is ended. Mainly a few countries like Middle-East countries supply the demand of mineral oils to whole world. The new emerging technology of pyrolysis for liquid fuel is a demand of time.

### 2. Pyrolysis principle

The pyrolysis of carbonaceous materials refers to incomplete thermal degradation resulting in char, condensable liquid or tar, and gaseous products. In its strictest definition, pyrolysis is carried out in the absence of air [1]. However, pyrolysis differs from gasification in that the products of interest are the char and a liquid, which is a result of incomplete nature of the process, retain much of the structure, complexity, and signature of the raw material undergoing pyrolysis. The relative proportions of the pyrolysis products depend on both process parameters as well as the composition of the feedstock. It is widely accepted that the most important process parameters are the operating temperature, heating rate, feed particle size, residence time of volatile and char, and the presence of catalyst Schoeters et al [2]. The physical and chemical constituent of the feedstock such as volatile, moisture and ash content also affect the product yield.

### 3. Objectives

- ❖ To design and fabricate a pyrolysis system.
- ❖ To produce pyrolytic oil from olive seeds and determine the properties of the pyrolytic oil.

### 4. Fixed bed pyrolysis

Pyrolysis may be either fixed bed pyrolysis or fluidized bed pyrolysis. Fluidized bed pyrolysis is more complex than fix bed pyrolysis. This project work was based on fixed bed pyrolysis. In fixed bed pyrolysis, a fixed bed pyrolyser is used. The feed material in the reactor is fixed and heated at high temperature. Thus feed material is converted into gaseous mixture which is then condensed for liquid production. Liquid petroleum or other inert (nitrogen) gas is used for making inert condition and for helping the gaseous mixture to dispose of from the reactor. The losses in fixed bed pyrolysis are relatively less than fluidized bed.

Following characteristics were considered:

- High operating temperature and corrosion resistance
- High thermal conductivity and Nontoxic.

After the theoretical analysis, the materials for various parts (reactor) were selected cast iron for its lower price and higher thermal conductivity. The condenser material was selected sheet metal by which making a cylindrical part. The sheet metal is easily available and lower cost.

## 5. Design criterion

- ❖ The process utilizes a fixed bed reactor and nitrogen gas to maintain inert condition.
- ❖ Short vapor residence time in the reactor and rapid condensation of the vapor
- ❖ Product to promote high yield of pyrolytic liquid product.
- ❖ Reliable heat supplies for heating the system and adequate gas flow rate to dispose of the vapor mixture.
- ❖ Proper mass flow rates of vapor and water for proper condensation.
- ❖ Size of the system is such that sufficient amount of pyrolytic liquid can be produced.

## 6. Description of work

Various operations were performed in different shops and laboratories of the university. In machine shops facing, turning, centering and boring etc. Operations were carried for various part of the rig in lathe machine and drilling of various flange and tubes were completed of various sizes in drill machine. The various parts of the setup were finished by grinding machine. Various joints as soldering was done for preventing leakages of the condenser after shim joining the sheet and for making a frame to hold the experimental set-up, gas welding was performed.

## 7. Mathematical arguments for design

### (a) For Reactor

For proper functioning of the reactor,

Internal dia.  $d = 2 \text{ in.} = 5.08 \text{ cm}$  (easily available in the market)

Vapor Residence Time,  $t = 4 \text{ Sec}$  ( $< 5 \text{ sec.}$ )

Gas Flow Rate in the Reactor,  $Q = 1 \text{ m}^3/\text{hr}$  ( $< 1-6 \text{ m}^3/\text{hr}$ )

Now,  $Q = A \cdot V$  (continuity equation) Or,  $Q = A \cdot L/t$  (velocity,  $V = L/t$ )

Or,  $L = Q \cdot t / A = (Q \cdot t^4 / \pi d^2) = 1 \cdot 4^4 / [3600 \cdot \pi \cdot (0.0508)^2] = 55.88 \text{ cm}$ .

### (b) For Condenser Dimensions

Assume for proper cooling of the vapor

Water flow rate =  $6 \text{ lit/min} = 0.1 \text{ kg/sec}$ ; [mass = density x volume]

Mass flow rate of the vapor =  $0.130 \text{ lit/min} = 0.0025 \text{ kg/sec}$ ; [assumption]

(On the basis of reactor dimension, temperature and feed quantity)

Specific heat of water,  $C_w = 4.2 \text{ kJ/kg-K}$

Specific heat of vapor,  $C_v = 2.2 \text{ kJ/kg-K}$

Water inlet temperature,  $t_{w1} = 25 \text{ }^\circ\text{C}$  [assumption]

Inlet temperature of vapor,  $t_{g1} = 450 \text{ }^\circ\text{C}$  [assumption]

Outlet temperature of vapor,  $t_{g2} = 40 \text{ }^\circ\text{C}$  [assumption]

Water outlet temperature,  $t_{w2} = ?$

The rate of flow of heat,  $Q = m_g C_v (t_{g1} - t_{g2}) = m_w C_w (t_{w2} - t_{w1})$

$Q = 0.0025 \cdot 2.2 \cdot (450 - 40) = 0.1 \cdot 4.2 \cdot (t_{w2} - 25)$

$Q = 3.08 \text{ kW}$  &  $t_{w2} = 32 \text{ }^\circ\text{C}$

The overall heat transfer between water and vapor,  $Q = U_o A T_m$

Where,  $U_o =$  Over all heat transfer co-efficient =  $320 \text{ W/m}^2\text{-K}$

$A =$  Minimum area of condenser tube

$\Delta T =$  Min log mean temp difference =  $(T_1 - T_2) / \ln (T_1 / T_2) = (425 - 8) / \ln 71.87 = 132 \text{ }^\circ\text{C}$

Where,  $T_1$  is the inlet temperature difference and  $T_2$  is the outlet temperature difference.

Using equation,  $3080 = 320 \cdot 132 \cdot A$  or  $0.072 = \pi d_c L_c$

If the diameter of the condenser tube,  $d_c = 2 \text{ inch} = 5.08 \text{ cm}$  (Commercially available)

Condenser tube length,  $L_c = 0.4572 \text{ m} = 45.72 \text{ cm}$ .

## 9. Major parts of pyrolysis System

### a) Reactor

The reactor is the main part of this pyrolysis system. The feed material and supply gas were held in the reactor. The reactor had been heated externally. Its dimensions were selected on the basis of various suitable arguments such as gas flow, gas residence time and cost etc. It is made of cast iron tube of 5.08 cm ID and 55.88 cm in length.

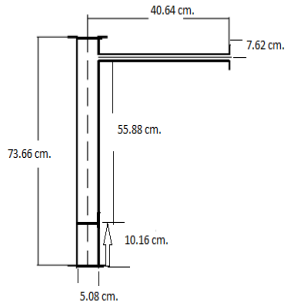

Fig.1. Sectional view of fixed bed reactor

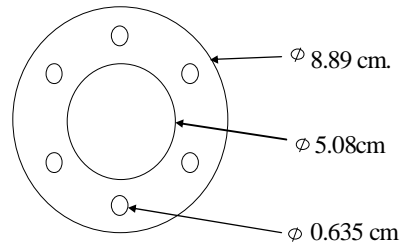

Fig.2. Sectional view of upper flange

### b) Condenser

The condenser is another important part of the experimental rig. To cool down the vapor product for getting liquid and non-condensable gaseous yields, the vapor products from reactor were passed through water cooled counter flow condenser. Its dimensions were also chosen by various operating arguments.

### c) Flow meter and liquid gasket

To measure the gas flow rate into the reactor, a flow meter was generally used at the top of the cylinder. But due to low gas pressure of liquid petroleum it was not possible to measure the gas flow by flow meter. The liquid gasket was used to make air tight between the flanges.

### d) Pyrometer

Pyrometer was used for metallurgical temperature measurements and control. It performs satisfactory up to about 1000 °C.

### e) Gas distributor

A simple nozzle-type gas distributor was adopted for proper distribution of gas into feed material. The gas distributor is shown in fig.4.

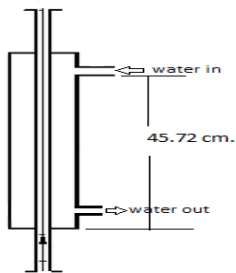

Fig.3. Sectional view of condenser.

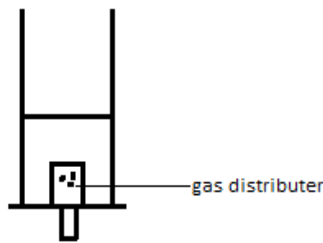

Fig.4. Gas distributor

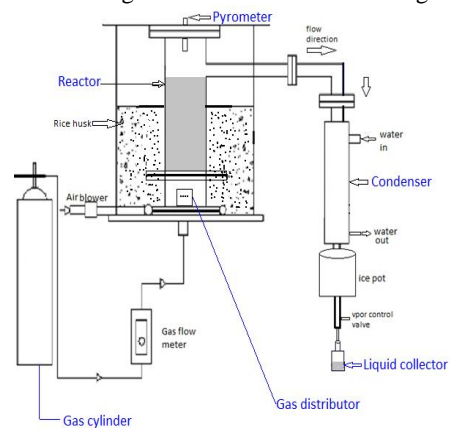

Fig.5. The schematic diagram of the fixed bed pyrolysis system

### f) Assembly of the rig

The rig was assembled on a frame structure made of mild steel angle bar. The rig was mounted by making rack in frame, so that the position of the rig was fixed. They were joined with each other or with reactor and condenser by locking screws with flanges.

## 10. Experimental procedure

At first the feed material was dried in 110°C before taken into the reactor and weighted to find the net weight of feed material. After weighting all joints and parts are checked to start the experiment, the reactor was heated externally by a biomass heating source from 400-550°C and this pressure was measured by thermometer. Nitrogen gas from cylinder was passed through the reactor at controlled rate. This high temperature with short residence time converts the feed stock into gaseous mixture and solid char. Nitrogen gas helps to disposed off the gaseous mixture (liquid and gas) to the collector through the condenser. The liquid product was collected in the liquid receiver and the non-condensable gas was collected in a water displacement collector to monitor gas flow rate and the gas volume. After the experimental run the biomass heating system was stopped and the amount of oil and char was measured. All the parts of the system were cleaned and the components were dried with air jet before reassembling for the next run. The fixed bed Pyrolysis system was run under the following operating conditions as-Operating bed temperature - 400 °C to 550°C; Pressure - Atmospheric; Gas -Nitrogen; Gas flow rate (L/min) - 4 to 8; Gas flow time (hr) -2 to 2.5; Apparent residence time less than 5.

## 11.Result

A total of twelve experimental runs were taken in this work by varying temperature, feed material size and running time. From figure 6 it is found that at the running time 150 min for operating temperature range 400 - 550°C and for 600-650 µm size feed materials the maximum pyrolytic oil yield is 44 wt% at 500 °C. After this temperature the pyrolytic oil yield is reduced because of tertiary reaction take place and vapor is not condensed as a result vapor % is increased. It is also found that the powder form gives the maximum oil yield than the other two feed materials size (size 0.7-0.9 and size 1.1-1.3).

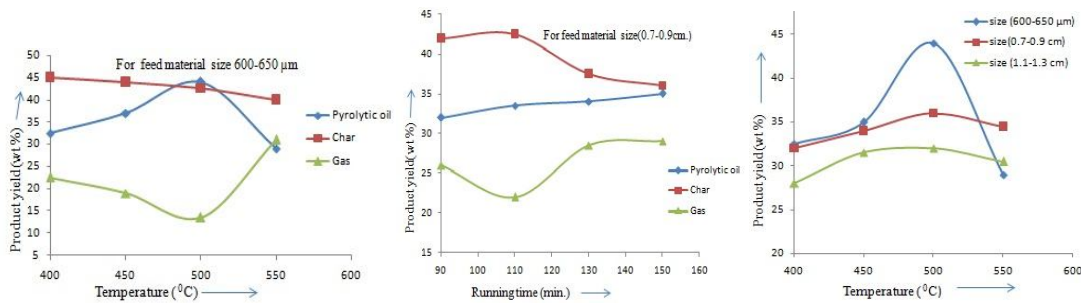

**Fig.6.** Effect of temperature, running time, feed materials size on product yield

After carried out the experimental studies by using biomass waste in the form of olive seeds and comparing this with the conventional diesel fuel it was found better & comparable results.

Analysis	Olive seed Oil
Kinematic viscosity at 270C (cSt)	5.81 ( oasltwate viscometer)
Density (kg/m3)	1040
Flash Point (°C)	70 ( Cleveland open cup Tester)
Fire Point (°C)	82
HHV of liquid(MJ/kg)	21.672 ( oxygen bomb calorimeter)
HHV of char(MJ/kg)	22.692

Analysis	Pyrolytic oil	Kerosene (Wikipedia)	Fast Diesel <sup>[4]</sup>	Diesel (Wikipedia)	Heavy Fuel Oil <sup>[5]</sup>	Wood Waste <sup>[3]</sup>
Kinematic viscosity at 26°C (cSt)	5.81	2.1	1.3-3.3 (50°C)		200 (50°C)	66.99
Density (kg/m3)	1040	800	780	860	980 (20°C)	1180.2
Flash Point (°C)	70	38	75	66	90-180	59
HHV(MJ/kg)	21.672	35.0	44.5	44.5	42.5	19.80



## 12. Recommendation

The following recommendations are suggested for improvement:

- ❖ The process of supplying the heat to the reactor bed may be coal or other less costly fuels and the external heating system (heater) should be insulated to reduce heat loss.
- ❖ The heating rate and temperature control should be proper with thermostat or other suitable systems that maintain the required temperature level at the system.
- ❖ The reactor can be redesigned as such types that the char be disposed off and observed easily and the energy contain gaseous products such as heat may be used for drying feed materials.

## 13. Conclusion

A pyrolysis system was designed, fabricated and Olive seeds were chosen as feed material for pyrolytic oil production. After taking the experimental studies by using solid waste in the form of olive seeds, it was found that this system takes less time for more liquid production. The pyrolytic oil was also characterized and analyzed for their physical properties. The properties of the liquid were compared with those of conventional fuel. All properties were almost close to those of conventional fuel.

## 14. References

- [1] Bridgwater A.V and Bridge S.A (1991). "A Review of Biomass Pyrolysis Technologies" In: Bridgwater A.V and Grassi G. (Eds). Biomass Pyrolysis Liquids Upgrading and Utilization. London: Elsevier Science; 11-92.
- [2] Buekens, A.G. and Schoeters, J.G. (1984). "Mathematical Modeling of Gasification." In Bridgwater, A.V. (Ed) Thermochemical Processing of Biomass. London: Butterworths; 177-199.
- [3] Andrews, R.G. and Patniak, P. C., 1996, "Feasibility of utilizing a biomass derived fuel for industrial gas turbine applications", In: Bridgwater AV, Hogan EN, editor Bio-Oil Production & Utilization, Berkshire: CPL, Press, pp. 236-245
- [4] Harker, J.H. and Bachurst J. R., 1981, Fuel and Energy, London: Academic Press.
- [5] Rick, F. and Vix, U., 1991, "Product standards for pyrolysis products for use as fuel in industrial firing plants", In Bridgwater AV, Grassi G, editor. Biomass Pyrolysis Liquids Upgrading and utilization, London: Elsevier Science, pp. 177- 218.

## Performance Comparison of Four Potential Seed Oil as a Feedstock for Bio-Diesel Production in Bangladesh

N. Hoque<sup>1\*</sup>, M. Mourshed<sup>1</sup>, M. R. A. Beg<sup>1</sup> and B. K. Das<sup>1</sup>

<sup>1</sup>Department of Mechanical Engineering, Rajshahi University of Engineering & Technology, Rajshahi-6204

\*Email: shumon99234@gmail.com, Phone: +8801716591872

### Abstract

This paper investigates the production of bio-diesel (BD) from karanja (*Pongamia pinnata*), pithraj (*Aphanamixis polystachya*), neem (*Azadirachta indica*) and mahua (*Madhuca longifolia*) seed oil by acid esterification followed by transesterification process and physicochemical properties of oils were studied. Study includes their effects on a DI diesel engine. All the oils were characterized by density, viscosity, specific gravity, pH value, flash point, fire points and cetane index using standard methods. The minimum BSFC 0.43kg/kW-hr was found for karanja bio-diesel at 4bar (BMEP) which was about 9.3% higher than neat diesel at the same condition. The brake power produced by the net diesel at 4 bar was 1.65 kW which was about 26.9% higher than the karanja seed bio-diesel. Maximum thermal efficiency 13.8% was observed for neat diesel, where as 11.45%, 10.90%, 10.63%, 10.38% was observed for karanja, neem, mahua and pithraj bio-diesel oil. Results indicate that these oils are potential biodiesel feedstock and can be used as an alternative to the diesel fuel in the near future.

Keywords: Biodiesel, Alternative fuel, methanol, transesterification process, catalyst.

### 1. Introduction

Rapid depletion of fossil fuels and stringent emission regulations strongly forced researchers to explore renewable sources of energy. Biodiesel is one of the promising renewable energy options already exploited by researchers in different countries. Different categories of feed stocks as sources of suitable oil for biodiesel production include seeds, nuts, leaves, wood, and even bark of trees. At present the world is highly dependent on petroleum fuels for generating power, vehicle movement, agriculture and domestic useable machinery operation and for running the different industries. With technological progress and improvement of living standard of the people the demand of the petroleum fuel increases simultaneously. But the reserve of the petroleum fuels are so evenly distributed that many regions have to depend on the others for their fuel requirements. The price of the petroleum is also increasing day by day and use of the petroleum fuel in engine produces harmful products which pollutes the environment. Due to the above reason, attention has gone to the search of renewable source of fuel which can meet the demand. Bangladesh has good potential of various edible and non-edible oils and locally available vegetable oils may be an alternative source of diesel fuel which can be produced in any local area [1].

Plant vegetable oils can be used as alternative fuels for diesel engine. Due to higher viscosity, lower volatility, carbon deposits and oil ring sticking, limit their direct uses to diesel engine [2]. There are several techniques to reduce the viscosity of vegetable oils. The techniques are dilution, pyrolysis micro emulsion and transesterification. Like vegetable oils, it is well known that biodiesel is also an alternative fuel and can be derived from straight vegetable oils (edible or inedible), animal fats, waste cooking oils or even from yellow grease through a process known as trans esterification [3]. The production of biodiesel involved in chemically reacting a vegetable oil or animal fat with an alcohol such as methanol. The reaction requires a catalyst, usually a strong base, such as sodium or potassium hydroxide, and produces new chemical compounds called methyl esters, which is known as biodiesel [4-5]. Most of the study suggests that engine power is reduced with the biodiesel as biodiesel has the low heating value compare to diesel. Factors which affect the engine power are content of biodiesel, properties of biodiesel and its feedstock, engine type and its operating conditions and additives. Proper optimization of injection timing, injection pressure and proper improvement of additives can solve this problem up to a great extent. And when biodiesel is used as blend with diesel are it is difficult perceive this problem. S. Romano et al. [5] reported that vegetable oils have acceptable cetane numbers, high viscosity (50 Cst), high flash points (220-285°C) and high pour points (-6 to 12°C) and substantial heating values (about 90 % of diesel) and low sulfur content (< 0.02% ) and also studied the properties of different

vegetable oils and modified fuels for automotive application. Srinivasa et al., 1991 [6], however, noted density increases when fueling with karanja based biodiesel.

In Bangladesh, non-edible renewable jatropha oil and pithraj (local name) oil can play a vital role in the production of substitute diesel fuel. Attention is given to the neem and pithraj oil because they are non-edible renewable source of oil and it is a new research over the world. The climatic and soil condition of Bangladesh is also suitable for the production of this plant. The oil as well as Bio-diesel can be prepared with most economical way. Nabi et al., 2009 [7] reported that by planting of jatropha, Bangladesh can reduce importing a huge amount (25%) of petroleum products from foreign countries as well as by planting of pithraj, can also be saved 21% of petroleum products.

The purposes of this study are to produce biodiesel from renewable sources of energy named pithraj oil, karanja oil, neem oil and mahua oil and to investigate the engine performance with these biodiesel blends (B10).

The subsequent section explains the materials and methods involved with the study, the comparison of neat diesel and the bio-diesel under consideration is given at third section. The performance of different bio-diesel is listed as results and discussions at section four. The environmental effect of bio-diesel emission is sorted at section five.

## 2. Materials and Methods

The most important parameters relevant to biodiesel production are the FFA content and moisture content [1,3]. The FFA content of vegetable oil will vary and depends on the quality of the feed stock. During alkali catalyst based transesterification, higher the FFA content of the oil needs more alkali to neutralize the FFA and it leads to soap formation and the separation of products becomes difficult and as a consequence low yields of biodiesel are produced [8]. Acid esterification are advantageous for those oils having high FFA, as acid catalyze the FFA esterification to produce fatty acid methyl ester (FAME), increasing the bio-diesel yield, but reaction time and alcohol requirement are substantially higher than those of base catalyzed transesterification [6]. In this study biodiesel (BD) from karanja (*Pongamia pinnata*), pithraj (*Aphanamixis polystachya*), neem (*Azadirachta indica*) and mahua (*Madhuca longifolia*) seed oil was produced by acid esterification followed by transesterification process due to high FFA concentration in these vegetable oils feedstock. For acid esterification  $H_2SO_4$  was used as catalyst and methanol and NaOH were used as base catalysts for transesterification process.

Firstly, the vegetable oils were filtered and preprocessed to remove water and contaminants, and then fed to the acid esterification process. For acid pretreatment, the oils were taken to the rounded flask where  $CH_3OH$  and 1%  $H_2SO_4$  were added to the flask and heated continuously for an hour. During heating and stirring the mixture, acid value and FFA concentration were tested. When the FFA concentration was less than 1%, the alkalinized transesterification was then conducted with pretreatment vegetables oil. In this process, different parameters including catalyst to oil ratio (w/w),  $CH_3OH$  to oil ratio (w/w), and the reaction temperature were investigated. The acid value was found to be less than 2% and the FFA concentration was less than 1% at a methanol to oil ratio of 55 wt.%. It was also observed that the maximum bio-diesel production, the volumetric percentage of  $CH_3OH$  was kept constant at 22% and temperature was varied from 40°C to 55°C and the weight percentage of catalyst was kept at 0.5%.

Table 1. Engine specification

Engine type	4-stroke DI diesel engine
Engine no.	4062 AVI
Number of cylinders	One
Bore × stroke	80 × 110 mm
Swept volume	553 cc
Compression ratio	16.5:1
Rated power	4.476 kW at 1800 rpm
Types of fuel pump	High pressure, mechanical type
Fuel injection pressure	14 MPa (at low speed, 900 to 1000 rpm) 20 MPa (at high speed, 1100 to 1800 rpm)
Fuel injection timing	24 °BTDC

The experimental study was conducted by using a single cylinder water-cooled, naturally aspirated (NA) 4-stroke DI diesel engine. The specifications of the engine are shown in Table 1. The flow rate of the fuel was measured by timing with a stop watch the consumption for known quantity of fuel (10cc) from a burette. The speed was measured directly from the tachometer attached with the dynamometer. The engine torque was measured by using rope brake dynamometer which is coupled to the engine. The cooling water outlet and exhaust gas temperature were measured directly from the thermometer attached to the corresponding passages. An inclined water tube manometer, connected to the air box (drum) was used to measure the air pressure. A high

pressure mechanical fuel pump and a pintle type fuel injector with a nozzle hole (nozzle diameter 0.25 mm) were used in the injection system. The fuel injection time was set at 24° BTDC. Initially the engine was run by the diesel fuel for about 30 minutes to warm up and bring to the stable condition. At that situation emission and exit line temperature was uniform and it was ensured to be constant for every observation to evaluate performance. At first the experimental data was taken for diesel and then for 90% diesel and 10% pithraj, karanja, neem and mahua bio-diesel oil.

The engine was running at different speed ranging from 900 to 1400 rpm and then selected 1200 rpm on the basis of maximum thermal efficiency. All the experimental data was taken for three times and used the mean of them was used by running the engine at 1200 rpm and different load conditions.

### 3. Comparison of Bio-Diesel Properties with Neat Diesel

The major properties of biodiesel include calorific value, diesel index, flash point, fire point, cloud point, pour point, density, and kinematic viscosity. The various physicochemical properties of diesel and biodiesel produced from pithraj, karanja, neem, and mahua seed are measured and presented in Table 2 for comparison. It can be noted that the calorific value of mahua biodiesel is 17% less than that of diesel, pithraj and neem oil has almost same calorific value but 13% less than the diesel oil whereas karanja oil has the highest calorific value than that of other three biodiesel. This might be due to the presence of oxygen atoms in the fuel molecule of bio-diesel [3-5]. The kinematic viscosities of biodiesel are greater than the diesel oil but mahua oil has the viscosity close to diesel oil.

Table 2. Comparison of various bio-diesel (B10) properties and diesel oil

Properties	Neat Diesel	Pithraj oil	Karanja oil	Neem oil	Mahua oil
Density (gm/cc)	0.86	0.948	0.9434	0.9466	0.872
Viscosity (cSt)	4.98	6.22	5.86	6.05	5.2
Higher heating value(kJ/kg)	44579	38588	40750	38150	37000
Fire point(°C)	90	210	220	228	150
Flash point(°C)	80	197	210	220	118
Cetane index	47	51	58	43	52
pH value	7	7.00-7.46	7.58-8.87	4.38-4.92	7.14-7.31

The higher viscosity of biodiesel could potentially have an impact on the combustion characteristics because the high viscosity affects its atomization quality. The flash and fire points of the four seeds biodiesel are much higher than that of diesel, which make biodiesel safer than diesel from ignition due to accidental fuel spills during handling. Pithraj oil, karanja oil and mahua oil has the higher cetane number while neem oil has lower cetane index compared to diesel oil [9]. The density of karanja oil, pithraj oil and neem oil has almost same but greater than mahua oil which shows almost same value that of diesel oil.

## 4. Results and Discussions

### Effect of Methanol Percentage on Biodiesel Yield

The transesterification process was performed to yield bio-diesel from the neem, karanja, pithraj and mahua by keeping the catalyst NaOH concentration constant at 0.5%. From the Fig. 1 it can be noted that the bio-diesel yield was varied with the varying CH<sub>3</sub>OH concentration (ranging from 16% to 24%). The bio-diesel yield was increased for all the non-edible seeds with the increase in CH<sub>3</sub>OH concentration up to a maximum near about 22% and then decreased steadily. This fact can be characterized by, with the increase of CH<sub>3</sub>OH concentration the rates of complete transformation of oil to bio-diesel is increased and after exceeding the optimum CH<sub>3</sub>OH concentration level it is found difficult to separate bio diesel from the water.

Although the emulsification process gets complicated with the increasing CH<sub>3</sub>OH concentration as it has one OH group that contributes to the more H<sub>2</sub>O production. The esterification reaction is presented in equation (1) as-

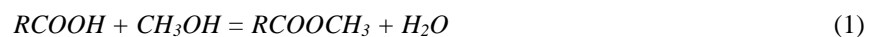

Also the higher CH<sub>3</sub>OH concentration causes more reaction time with higher density. The maximum bio-diesel yield could be attained for the seeds under consideration were about 22% of CH<sub>3</sub>OH concentration (% wt) while the temperature range was varied from 40°C to 55°C. From the experimental data it was obvious that, the maximum bio-diesel yield was obtained for the neem seeds due to its physiological properties which correspondent with the previous research [10].

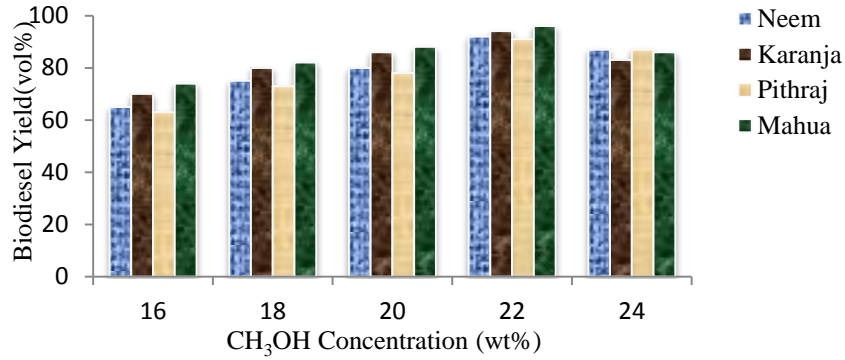

Fig.1. Variation of bio-diesel production with CH<sub>3</sub>OH (% wt)

The concentration of the NaOH catalyst was varied from 0.4% to 0.55% by % of wt. For the optimum bio-diesel production the volumetric percentage of CH<sub>3</sub>OH was kept constant at 22% and temperature was varied from 40°C to 55°C. It was observed that, the bio-diesel production increases with the increase in the catalyst concentration until it reach to a value about 0.48 wt% to 0.5 wt% and then decreases with the decreases in catalyst concentration. But with increasing amount of catalyst causes higher free fatty acids (FFA) and forms more wax and glycerol. Also higher NaOH content results in soapification reaction which hampers bio-diesel production.

#### Effect on Brake Specific Fuel Consumption for Various Bio-Diesel Fuels

The average effective cylinder pressure that does useful work obtained calculated from the engine ‘brake horse power (BHP)’ is referred as the “Brake Mean Effective Pressure or BMEP”. It’s a function of temperature of gases in cylinder. To obtain more heat energy, more fuel needs to be burnt. Whereas torque is a function of BMEP and engine displacement. On the other hand, the, BHP is a function of engine speed and torque. The ratio of the work done during one complete engine revolution to the engine swept volume, gives the engine BMEP. Thus, BMEP measures the effective work output of the engine.

$$BMEP = \frac{2\pi TN}{V_s} \quad (2)$$

In equation (2), T refers to torque developed (N-m), N is the number of revolution per cycle (N=1 for two stroke engine and N=2 for four stroke engine), V<sub>s</sub> is the swept volume (m).

The variation of the BSFC with neat diesel fuel and different biodiesel is depicts in Fig. 2. BSFC for various bio-diesel decreases with the increases in BMEP and reaches it minimum value near at BMEP 4 bar. At the initial stage the BSFC decreases which may be accredited to the complete combustion of fuel. After a while the engine reaches the full load level and the time for complete combustion gets reduced and a slender raise in BSFC is observed. This fact can be illustrated as, the brake power of the engine increases with the load but the time needed for the complete combustion of a certain amount of fuel is increased. Thus the BSFC is decreased after attaining full load.

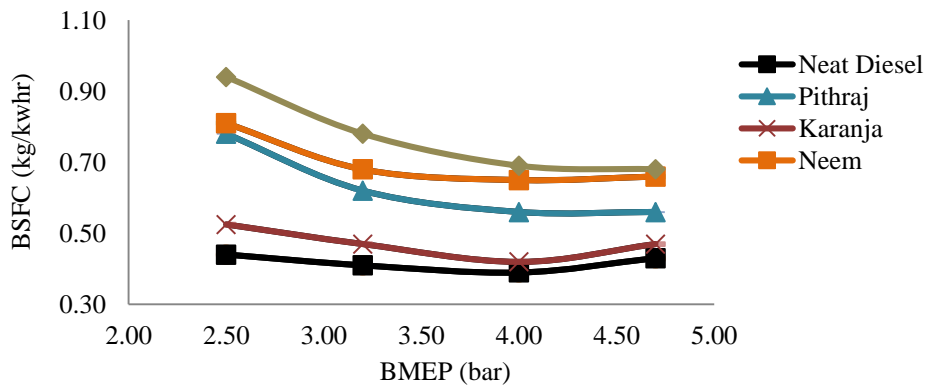

Fig. 2. BSFC with neat diesel and different bio-diesel fuels

The BMEP obtained for Karanja oil has the lower BSFC than the other three type biodiesel and close to diesel oil at BMEP 4 bar. From Fig. 2 it is clear for different engine loads that the BSFC is higher for all the bio-diesel

than neat diesel due to the higher heating value of the diesel fuel and a higher content of oxygen in bio-diesel [11]. Also the viscosity and specific gravity of the bio-diesel fuels affects the atomization process as well as the BSFC of the fuel.

### Effect on Engine Brake Power for various Bio-Diesel Fuels

The general trend of the curves in Fig. 3 represents that the BP of crank shaft increases with the increase in BMEP up to a certain value (around 4 bars) of BMEP and then decreases. At around 4 bar the BP for neat diesel is higher than karanja, pithraj, neem and mahua oil by 16.97%, 34.55%, 38.1% and 45.45% respectively. The calorific value of different fuels is an indication to the energy output by the fuel. Thus, neat diesel has the highest energy output among the others. From Fig. 3, it is also evident that, after reaching the full load condition incomplete combustion takes place and the energy output for all fuels are decreased that also reveals the earlier reports on bio-diesel fuels [11-12].

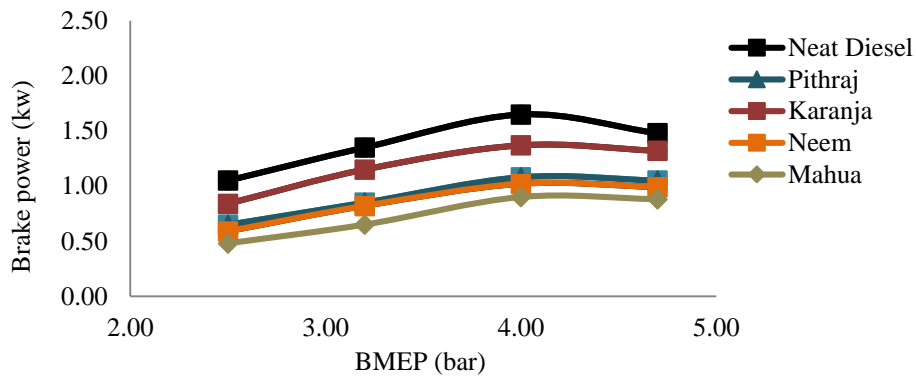

Fig. 3. Brake power with neat diesel and different bio-diesel fuels

### Effect on Engine Thermal Efficiency for Various Bio-Diesel Fuels

The brake thermal energy indicates the proportion of thermal energy extracted by combustion system and transfers the suitable mechanical work to the crank shaft.

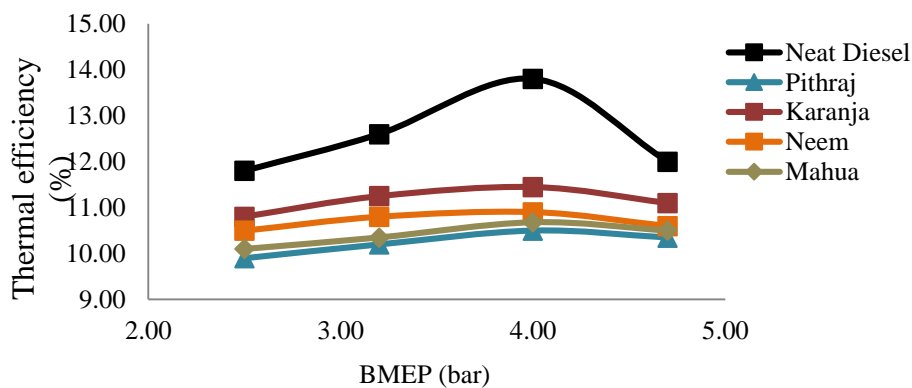

Fig.4. Thermal efficiency with neat diesel and different bio-diesel fuels

Fig. 4 illustrates the variation of thermal efficiency with BMEP for neat diesel and various bio-diesel fuels. The trends of the curves follow an increase in the efficiency with the increase in BMEP up to almost 4 bar and then slightly decreased. The initial increase is due to the proper combustion of the fuel and for bio-diesel excess amount of oxygen contributes to a greater extent. But after reaching full load the efficiency is decreased due to incomplete combustion of fuel with a higher BSFC [13-14]. From the above equation it is clear that the engine torque increases with the engine load and results in a higher thermal efficiency. At higher load more fuel is injected in the combustion chamber and causes incomplete combustion of fuel. Thus the thermal efficiency is decreased.

## 5. EMISSION

Engine emission is mainly characterized by the  $\text{NO}_x$  and  $\text{CO}_x$  emission.  $\text{NO}_x$  formation varies with the engine maximum temperature (attains before the end of compression stroke), fuel injection angle, engine operating condition, type of fuel used [8-9]. With an increase in temperature, the higher  $\text{O}_2$  content of bio-diesel causing

oxidation of the nitrogen. This concentrated NO<sub>x</sub> remains unchanged after the expansion stroke. On the contrary, this excess O<sub>2</sub> content of bio-diesel produces leaner A/F ratio compared to diesel [11]. This excess O<sub>2</sub> content causing the emitted CO to be oxidized and formed into CO<sub>2</sub>. Thus, bio-diesel attributes to the reduction of CO<sub>x</sub> and increment of NO<sub>x</sub> formation compared to the diesel fuel at the same engine operating condition.

## 6. CONCLUSION

This experimental work was conducted to produce the bio-diesel from the potential inedible feedstock in Bangladesh which will be a novel alternate to the traditional diesel fuel. In this work bio-diesel was extracted from the karanja (*Pongamiapinnata*), pithraj (*Aphanamixispolystachya*), neem(*Azadirachtaindica*) and mahua(*Madhuca longofolia*) seed oil, their properties were compared and a detail of their performances were investigated. The following conclusion can be drawn for this work-

- i. Bio-diesel was produced by using the transesterification process. The optimum condition for bio-diesel production was set close to 22 vol% of methanol, 0.5wt% of NaOH and 55 ° C reaction temperatures. At this condition maximum bio-diesel was obtained 96% for mahua oil, 94% for neem oil, 92% for pithraj oil and 91% for karanja oil. The maximum bio-diesel production was determined after 15hrs of reaction time.
- ii. The different physiochemical properties of bio-diesel was evaluated and compared with the diesel fuel. The experimental data shows that the characteristics of all four inedible oil as bio-diesel are quite close to neat diesel. The density, viscosity, flash point and fire point is higher for bio-diesel fuel that is not desirable but the cetane number of bio-diesel is very promising except Neem oil.
- iii. Brake thermal efficiency of bio-diesel was lower than the diesel at the same rated load due to the lower heating value and higher BSFC of the bio-diesel.

Thus, from a consideration of 3E's (energy, economy and environment), the bio-diesel fuel can be a prospective feedstock for Bangladesh which is also renewable in nature.

## REFERENCES

1. M.N. Nabi, N. Hoque, M.S. Akhter, "Karanja (*Pongamia pinnata*) biodiesel production in karanja biodiesel and its effect on diesel emissions", Elsevier Fuel Processing Technology, Vol. 90, pp. 1080–1086, 2009.
2. M. N. Nabi, M. S. Akhter and M. M. Z. Shahadat, "Improvement of engine emissions with conventional diesel fuel and diesel-biodiesel blends", Bioresource Technology, Vol. 97, pp. 372-378, 2006.
3. H. Fukuda, A. Kondo and H. Noda, "Biodiesel fuel production by transesterification of oils", J BiosciBioeng, Vol. 5, pp. 405–416, 2001.
4. M.N. Nabi, N. Hoque and M.S. Uddin, "Production of Bio-Diesel in Bangladesh from Inedible Renewable Pithraj Oil and Experimental Investigation of Methyl Esters as Bio-Diesel on C.I. Engine", International Energy Journal, Vol. 11, pp. 73-80, 2010.
5. S. Romano, "Vegetable Oils – A new Alternative. Vegetable oil Fuels", Proceedings of the International Conference on Plant and Vegetable oil Fuels, ASAE Publication, Vol. 4, No. 82, 1982.
6. R. P. Srinivasa and K. V. Gopalakrishnan, "Vegetable oils and their methylesters as fuels for diesel engines", Indian Journal of Technology, Vol. 29, pp. 292-297, 1991.
7. M. N. Nabi, N. Hoque and M. S. Uddin., "Prospect of *Jatropha curcas* and Pithraj Cultivation in Bangladesh", Journal of Engineering and Technology, Vol. 7 No. 1, pp. 41-54, June 2009.
8. M. A. Fazal, A. S. M. A. Haseeb and H. H. Masjuki, "Biodiesel feasibility study: An evaluation of material compatibility; performance; emission and engine durability Renew", Sustain. Energy. Reviews, Vpl. 2, No. 15, pp. 1314-1324, 2011.
9. S. Murillo, J.L. Miguez, J. Porteiro, E. Granada, J.C. Moran, "Performance and exhaust emissions in the use of biodiesel in outboard diesel engines", Fuel, Vol. 86, No. 7.1, pp.1765, 2010.
10. M. H. Ali, M. Mashud, M. R. Rubel, R. H. Ahmad, "Biodiesel from Neem oil as an alternative fuel for Diesel engine", Procedia Engineering, Vol. 56, pp. 625– 630, 2013.
11. M. Zheng, MC. Mulenga, G.T. Reader, M. Wang, D.S.K Ting, J. Tjong, "Biodiesel engine performance and emissions in low temperature combustion", Fuel, Vol. 87, pp. 714–22, 2008.
12. H. Raheman, AG. Phadatare, "Diesel engine emissions and performance from blends of karanja methyl ester and diesel", Biomass Bioenergy Vol. 27, pp. 393–7, 2004.
13. K.Anbumani, A.P.Singh, "Performance of Mustard and Neem Oil Blends with Diesel Fuel in C.I. Engine", ARPN Journal of Engineering and Applied Sciences, Vol. 5, pp. 1819-6608, 2010.
14. S. Puhan, Vedaraman, N.Sankaranarayanan, N.G. Rama, "Performance and emission study of Mahua oil (*madhuca indica* oil) ethyl ester in a 4-stroke natural aspirated direct injection diesel engine", Renewable Energy, Vol. 30, pp. 1269–1278, 2005.