

A Binary Code Lock System

Wafdur Rahman Abrar¹, Md Fazlul Kader¹ and Mahfuzulhoq Chowdhury²

¹Dept. of Applied Physics, Electronics and Communication Engineering, University of Chittagong, Chittagong, Bangladesh

²Dept. of Computer Science & Engineering, Chittagong University of Engineering & Technology, Chittagong, Bangladesh

Email: wafdur.rahman@yahoo.com; f.kader@cu.ac.bd; mahfuz_csecuet@yahoo.com

Abstract— The proposed system is intended to protect electrical appliances with a simple lock system. As for passcode, a 4 bit binary number is used. To input the pass code, four two state switches are utilized. The pass code is stored in a memory. It can be changed after unlocking the lock system using valid pass code. We use D type flip-flops as memory. The comparator unit compares input codes with the stored code to generate the signal required to open the lock. The system is hardware implemented and has the versatility in application.

Keywords: Code lock; Pass code; Comparator

I. INTRODUCTION

A locking device which is operated by electric current is called an electronic lock or more precisely electric lock. More often, electric locks are used for access control. A Code lock system is a kind of electronic lock system where a code is used for unlocking the lock. Only for the valid code the lock opens, otherwise it remains locked. A Binary code lock system is the one in which the code is a binary number instead of a decimal number. It makes the input process a lot simpler down to just opening or closing a series of switches. The valid code is stored in a memory element comparisons to which an unlock command is generated for a valid input code to open the lock.

There are several ways to implement binary coded lock system [1-5]. In [1], the proposed system is built by using only one 8-position DIP switch. But, this can also be implemented by two switch assemblies. In this approach, one switch acts to hold the correct code for

unlocking the lock, while the other switch serves as a data entry point for the person trying to open the lock. A microcontroller based approach is implemented in [2] where an Atmel AT89C2051 (U1) microcontroller is used to build the system. Solenoid is controlled from a power MOSFET IRF540 (VT3). This additional transistor is useful as it translates the microcontroller unit logic levels to 0V and 12V, capable to drive the solenoid. A single integrated circuit based approach is implemented in [3], which requires a code of seven digits. In [4], the authors proposed a binary single-key-lock system for access control.

In this paper, we proposed a binary code lock system which is completely different than others. We used flip-flop memory and EX-OR gates as a comparator. A 4 bit binary number is used as a passcode. The stored passcode is compared with the input passcode to unlock the system. D flip-flop is used as memory to store the passcode and comparator unit compare input codes with the stored code to generate unlock command.

The rest of this paper is organized as follows. In section II, we introduce the design overview of our proposed system. In section III, we illustrate experimental results & discussions and finally we conclude this paper in section IV.

II. DESIGN OVERVIEW

In Fig.1, we show the block diagram of our proposed binary code lock system.

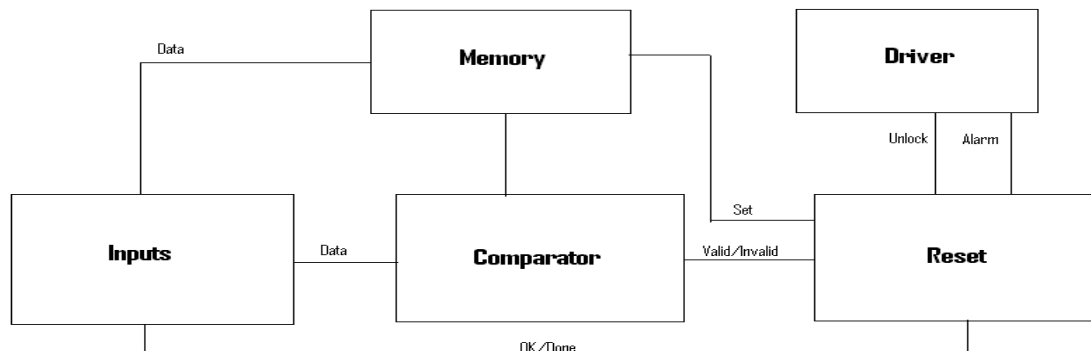

Figure 1. Block Diagram of the proposed binary code lock system.

A. Inputs

Four two state push button switches are used as data inputs which are shown in Fig. 2. They are used to input logic 0 or 1 to the memory as well as comparator. There are also three control inputs, which are Set, Done/Ok and Unlock.

- Set is used to change stored memory data.
- Done/OK is used to signal the completion of input.
- Unlock is used to open the lock.

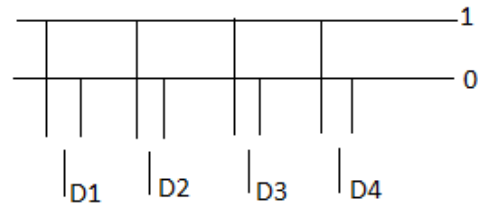

Figure 2. Inputs.

B. Memory

Four D flip-flops are used as memory to store four bit binary data shown in Fig. 3. Stored data can be changed using Set command which is actually a clock signal to the memory flip-flops. The outputs of the flip-flops are delivered to the comparator for decision making.

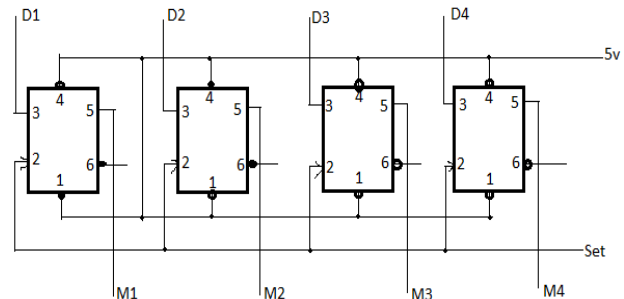

Figure 3. Memory circuit.

C. Reset

The reset unit is basically a D flip-flop shown in Fig. 4. Its data input is the inverted comparator output. OK/Done command stores the comparator output and the inverted output of the reset flip flop is used to generate Unlock and Set command which can be activated by corresponding control input.

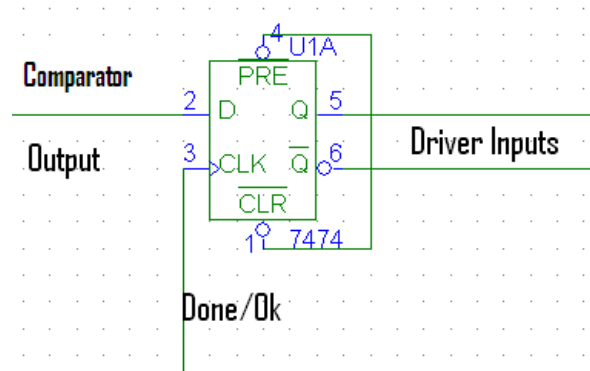

Figure 4. Reset circuit.

D. Comparator

The comparator unit is shown in Fig. 5. The input data and memory data are compared by four XOR gates. If an input-memory data pair matches, XOR output becomes 0 which is inverted and the inverted output of all four XOR gates are ANDed. Hence, if the input and memory code are identical, the comparator output goes high which is connected to the reset unit.

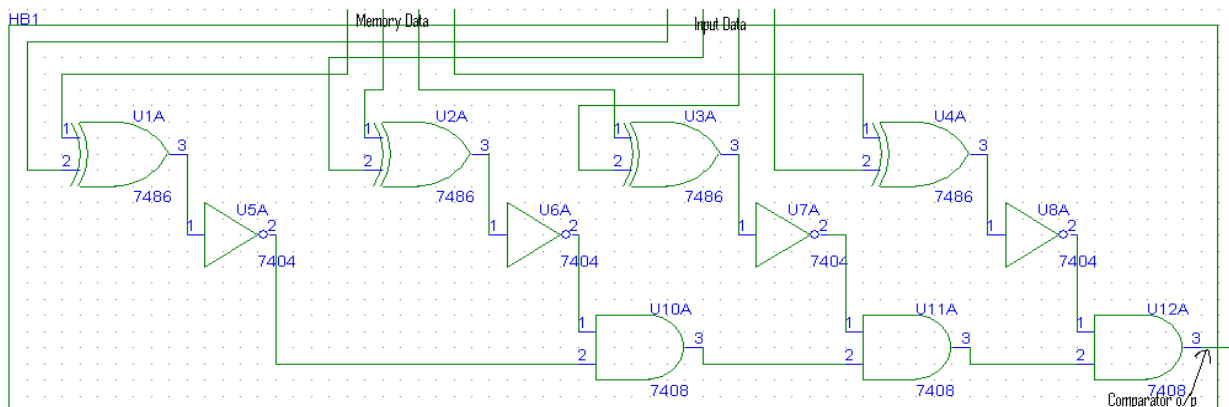

Figure 5. Comparator circuit.

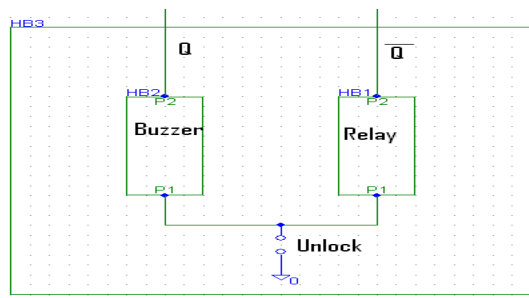

Figure 6. Driver circuit

E. Driver

The driver unit consists of a relay and a buzzer shown in Fig. 6. Both are activated by the unlock command. For a valid code, the inverted output of the reset flip-flop goes high which activates the relay. For an invalid code, the non-inverted output of the reset flip-flop goes high and sounds the buzzer.

F. Complete circuit diagram of the proposed system

In Fig. 7, we show the complete circuit diagram of the proposed system. The operation of the system can be described as follows:

- Initially the code is set to 1111 by default.
- To unlock for the first time, we input 1111 via data inputs.
- Then, we activate OK/Done control input.

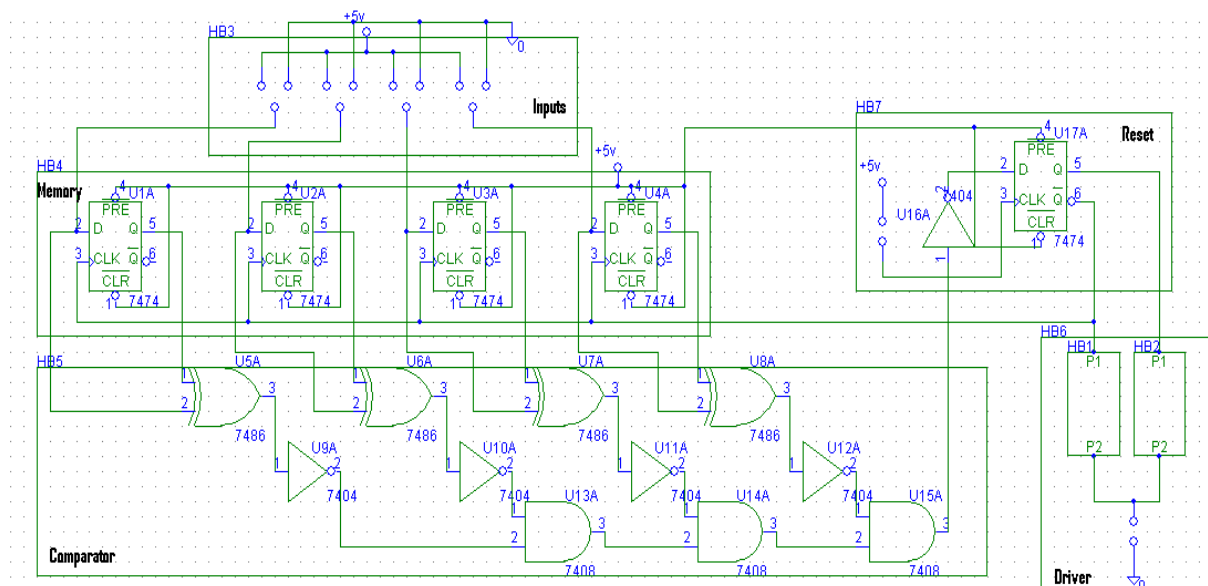

Figure 7. Complete circuit diagram of the proposed binary code lock system.

In addition, other than the advantages, it has some limitations such as less secure due to only 16 possible

- To change the code, we input the code that we want as the pass code via data inputs and activate Set input. Hence, the code has changed.
- To lock the system, we give any invalid code and activate OK/Done.
- Now, to unlock we must use the changed code otherwise activating Unlock input will trigger the alarm.
- With valid code activating Unlock input will turn on the relay and so the locked appliance.

III. EXPERIMENTAL RESULTS AND DISCUSSIONS

We activate the lock using initial default code 1111. Then, we set the code to 1100. Afterward, we tried to open the lock using 1101 which sounds the buzzer. To turn the buzzer off, we use 1100 and this buzzer goes off and the relay is turned on. Then, we set the input to 0101 and press Set to change the code to 0101. Now, any code other than 0101 triggers the buzzer whereas only 0101 turn on the relay by pressing Unlock control input. However, the proposed system offers several advantages such as low complexity, low computational cost, easy installation, alarming unauthorized attempts to use electrical devices as well as can be used to control electricity usage thus saving electricity bill. Moreover, people with the zero technical knowledge can operate the system by following the instructions.

pass codes possible, adding additional bits for pass code exponentially increase the circuit complexity and

difficult to troubleshoot. In our future work, we will consider these problems so that our proposed system can be available for commercial purposes.

IV. CONCLUSION

We successfully implemented the binary code lock system. In the proposed system, we utilize some basic components of digital electronics. The idea was to utilize something very simple and turn it into something of much greater use. With the proposed system, we can effectively secure our electrical appliances and control the use of valuable electrical energy in our home or office. It may be used to lock doors, cars and small safe's also with a little improvisation. Hence, it offers a wide range of applications and does not require any fancy component which decreases the cost significantly.

REFERENCES

- [1] Simple Combination Lock, [Online]. Available: http://www.Learning-electronics.net/vol_6/chpt_7/7.html
- [2] iButton electronic lock, [Online]. Available: <http://www.electronics-lab.com/projects/sensors/001/index.html>
- [3] Electronically Lock for Door by Keypad mini project, [Online]. Available: <http://www.examsadda.com/2011/05/electronically-lock-for-door-by-keybad.html>
- [4] C.K. CHANG AND T.M. JIANG, "A BINARY SINGLE-KEY-LOCK SYSTEM FOR ACCESS CONTROL," IEEE TRANSACTIONS ON COMPUTERS, VOL.38, NO.10, PP.1462-1466, 1989.
- [5] Il-kyu Hwang, J. Baek, "Wireless access monitoring and control system based on digital door lock," IEEE Transactions on Consumer Electronics, vol. 53, No.4, November 2007.