

True Three-Phase Bidirectional Switch Based Buck AC Voltage Controller Topology

Mohammad Rubaiyat Tanvir Hossain*, Md. Faisal[§]

Department of Electrical & Electronic Engineering
Chittagong University of Engineering & Technology
Chittagong – 4349, Bangladesh

E-mail: *mrthossain@cuet.ac.bd, [§]fsl_3319@yahoo.com

Mohammad Ali Choudhury

Department of Electrical & Electronic Engineering
Bangladesh University of Engineering & Technology
Dhaka – 1205, Bangladesh

E-mail: mac@eee.buet.ac.bd

Abstract—Two bi-directional switch based three-phase buck AC voltage controller is presented in this paper. The operational principle of the proposed three-phase regulator is a direct consequence of using two three-phase bi-directional switches in the buck converter topology. The converter works on per phase basis and therefore three phase output voltages remain same in case of load unbalance. The topology has reduced number of switches for a three-phase AC voltage control having output voltage regulation, input current shaping and power factor improvement capability. Reduced number of switches allows simple control circuit, less switching loss, reliable operation and low cost. Steady state analysis and simulation results of open and closed loop control of the proposed converter are presented in this paper. The voltage mode feedback control method used for controlling the regulator shows acceptable regulation of the converter output voltage. During sudden variation of load or input voltage the controller adjusts the duty cycle to recover to the desired output voltage.

Keywords—ac voltage controller; automatic voltage control; buck converter; power quality; pulse width modulation;

I. INTRODUCTION

AC voltage controller is a kind of power converter that converts a fixed voltage, fixed frequency AC input supply to a variable voltage AC output delivered to a load through the use of power semiconductor devices [1]. They have applications in light illumination control, industrial heating, power conditioning and power flow control, speed regulation of fans, pumps, and blowers, soft starting of AC motors, etc. [2]-[11]. Transformer based AC voltage controllers are big and weighty, have sluggish response, include harmonics and need a great number of switches for better regulation [12]. Thyristor based converters have poor power quality problems and adversely affect the machines, transformers, and cables and the supply power at the end of common coupling [12], [13]. Bulky and large filters are required to decrease the harmonics and increase the power factor at input side. The progress in power semiconductor devices and their use as high-power, low loss and high frequency switching devices with high frequency control results in a variety of AC voltage controller topologies with fewer number of switches, reduction of overall circuit size and volume and improvement of power quality and transient response [14]-[22]. In [17], S. Srinivasan et. al proposed a group of three-phase switch mode AC-AC voltage

converters with six AC bidirectional switches, namely – Buck, Boost, Buck-Boost and Ćuk. F. Z. Peng et al. in [18], replaced the three main switches and the three freewheeling switches used in the AC voltage controllers presented in [17] by two three-phase semi bi-directional switches each consists of a unidirectional controlled switch enclosed by a three phase diode rectifier bridge. Similar two semi bi-directional switch based three-phase Z-source AC voltage converter was proposed by X.P. Fang et. al [19]. The semi bi-directional switch based three phase AC voltage converters of [18], [19] require opening of neutral connection of source and load. Because of lack of load/source side neutral these topologies have the limitation that in case of unbalanced loads, load currents become unbalanced which also changes the phase voltages. This shortcoming has been overcome in three phase rectifiers [20] and AC voltage controllers [21], [22] having modular structure in which the converter works on per phase basis. A new three phase AC bidirectional switch has been introduced as shown in Fig. 1 which composed of a unidirectional switch enclosed by two three phase diode bridges on either side. This true three-phase AC bidirectional switch allows modular operation even if the converter neutrals are not connected. As a result three phase output voltages remain same in case of load unbalance. Phase by phase modular operation permits the converters to have N number of phases with two bidirectional switches consisting of 2 unidirectional switches and 8N number of diodes.

This paper describes a three-phase switched mode Buck AC voltage controller with two three-phase AC bidirectional switches. Steady state analysis and performance of the converter both in open and closed loop control has been observed. Voltage mode feedback control with simple PI controller has been used for output voltage regulation. of the proposed converter. The controller performance for sudden input voltage and load variation has also been examined.

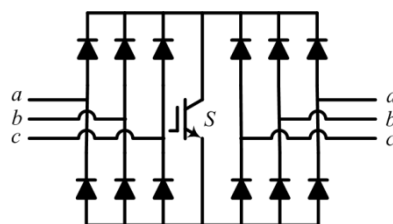

Fig. 1. New three-phase AC bidirectional switch

II. THREE PHASE BUCK AC VOLTAGE CONTROLLER

Buck converter is used as a means of reducing the instantaneous voltage across the load. Fig. 2 illustrates the circuit diagram of the proposed three-phase Buck AC voltage controller. It includes three buck inductors L_a, L_b, L_c , output filter capacitors $C_{a_of}, C_{b_of}, C_{c_of}$, and load resistances RL_a, RL_b, RL_c , along with two three phase AC bidirectional switches $S1$ and $S2$. The two switches are operated in alternating intervals by applying high frequency pulses at each gate. During the switching interval when the switch $S1$ is ON and $S2$ is OFF, inductor current increases which also passes through the load and back to the source. When switch $S2$ is closed while $S1$ is open inductor current freewheels through the switch $S2$ and load. The proposed Buck converter circuit thus operates per phase basis both in positive and negative cycles of input voltages.

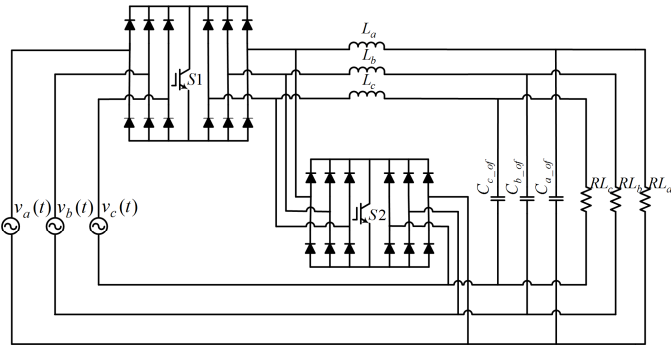

Fig. 2. Proposed three phase Buck AC voltage controller with two three phase AC bidirectional switches.

III. ANALYSIS OF BUCK AC VOLTAGE CONTROLLER

The proposed three phase Buck AC voltage controller can be considered as three single phase AC-AC Buck converter, phase 'a' of which appears as shown in Fig. 3. In phase 'a', two equivalent circuits of the two states can be achieved for a generalized switching cycle, as shown in Fig. 4 and Fig. 5. Since the switching frequency f_s is much higher than the AC line frequency f_l , in a switching period, the line frequency variables (such as input voltage) can be treated as constant.

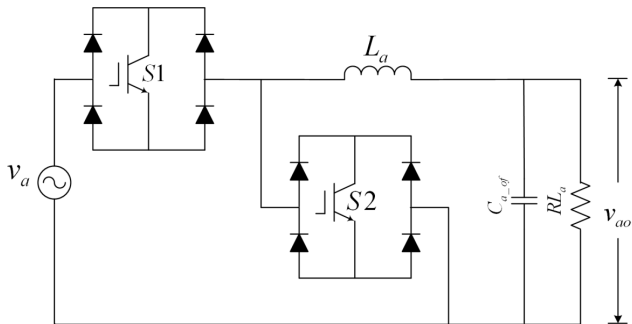

Fig. 3. Equivalent circuit of the phase 'a' of the proposed three-phase Buck AC voltage controller.

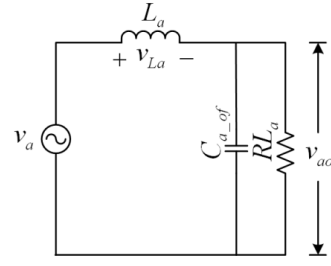

Fig. 4. Single phase equivalent circuit in state 1.

State 1 (S1 ON, S2 OFF): The single-phase equivalent circuit becomes as shown in Fig. 4. Applying KVL, voltage across the inductor can be expressed as,

$$\langle v_{La} \rangle_{T_S} = \langle v_a \rangle_{T_S} - \langle v_{ao} \rangle_{T_S} \quad (1)$$

State 2 (S1 OFF, S2 ON): The single-phase equivalent circuit turns out to be as shown in Fig. 5. According to KVL, the inductor voltage is,

$$\langle v_{La} \rangle_{T_S} = -\langle v_{ao} \rangle_{T_S} \quad (2)$$

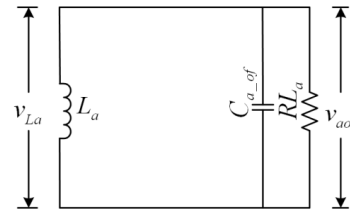

Fig. 5. Single phase equivalent circuit in state 2.

The switching period,

$$T_S = t_{S1} + t_{S2}$$

The duty cycle, D of the converter is defined as,

$$D = \frac{t_{S1}}{T_S}$$

The complement of the duty cycle is,

$$(1-D) = \frac{t_{S2}}{T_S}$$

In a generalized switching cycle, the inductor volt-second is,

$$\int_t^{t+T_S} \langle v_{La} \rangle_{T_S} dt = \int_t^{t+DT_S} (\langle v_a \rangle_{T_S} - \langle v_{ao} \rangle_{T_S}) dt + \int_{t+DT_S}^{t+T_S} (-\langle v_{ao} \rangle_{T_S}) dt$$

In AC-AC switching converters, in steady state, total volt-second of an inductor over one line frequency AC-cycle should be equal to zero. From volt-second balance,

$$\sum_{i=1}^n \int_{t_i}^{t_i+T_S} \langle v_{La} \rangle_{i T_S} dt = 0$$

$$\text{Here, } n = \frac{\text{AC line Period, } T_l}{\text{Switching Period, } T_S} = \frac{\text{Switching frequency, } f_s}{\text{AC line frequency, } f_l}$$

This implies,

$$\sum_{i=1}^n \int_{t_i}^{t_i+DT_s} \left(\langle v_a \rangle_{iT_s} - \langle v_{ao} \rangle_{iT_s} \right) dt + \sum_{i=1}^n \int_{t_i+DT_s}^{t_i+T_s} \left(-\langle v_{ao} \rangle_{iT_s} \right) dt = 0$$

Which can be expressed as,

$$\sum_{i=1}^n \left(\langle v_a \rangle_{iT_s} - \langle v_{ao} \rangle_{iT_s} \right) DT_s + \sum_{i=1}^n \left(-\langle v_{ao} \rangle_{iT_s} \right) (1-D)T_s = 0$$

Simplifying we get,

$$\sum_{i=1}^n \langle v_{ao} \rangle_{iT_s} = D \sum_{i=1}^n \langle v_a \rangle_{iT_s} \quad (3)$$

with $T_s \rightarrow 0$ or $n \rightarrow \infty$, we can write

$$\sum_{i=1}^n \langle v_a \rangle_{iT_s} = v_a = V_{im} \sin(\omega t), \text{ and}$$

$$\sum_{i=1}^n \langle v_{ao} \rangle_{iT_s} = v_{ao} = V_{om} \sin(\omega t - \theta)$$

Thus equation (3) can be expressed as,

$$v_{ao} = Dv_a = DV_{im} \sin(\omega t) \quad (4)$$

In three phase, the voltage gain expression can be written as

$$\begin{bmatrix} v_{ao} \\ v_{bo} \\ v_{co} \end{bmatrix} = D \begin{bmatrix} v_a \\ v_b \\ v_c \end{bmatrix} = DV_{im} \begin{bmatrix} \sin \omega t \\ \sin(\omega t - 120^\circ) \\ \sin(\omega t + 120^\circ) \end{bmatrix} \quad (5)$$

Equations (4) and (5) respectively define the voltage gain expression of single and three phase Buck AC voltage controller. The input/output relationship indicates that the instantaneous output voltages of the proposed Buck AC voltage controller is lower than input voltages. Controlling the duty ratio of the control signal the output voltage can be controlled in step-down fashion. In practice, switching loss, inductor/capacitor non-idealities, diode/switch conduction losses will cause deviation of ideal gain relationship in practical circuits, which eventually will not allow the circuit to work at high efficiencies at all duty cycles.

IV. THREE-PHASE BUCK REGULATOR WITH FEEDBACK CONTROL

Converter systems require closed loop automatic adjustment of duty cycle to regulate the output voltage within a set limit in spite of fluctuations in supply voltage and in load. Fig. 6 shows the voltage mode feedback control scheme for the proposed three-phase Buck AC voltage controller where the output voltages of the converter were regulated to 150V (peak) from a three-phase balanced input source with peak voltage amplitude of 300V. The feedback signal has been taken as the DC average of the output voltage of a single-phase and is compared with a DC reference signal. The error between the two is compensated by a PI controller. The controller parameters (gain= 1, time constant= 20ms) have been chosen by Ziegler-Nichols tuning method. The controller output is

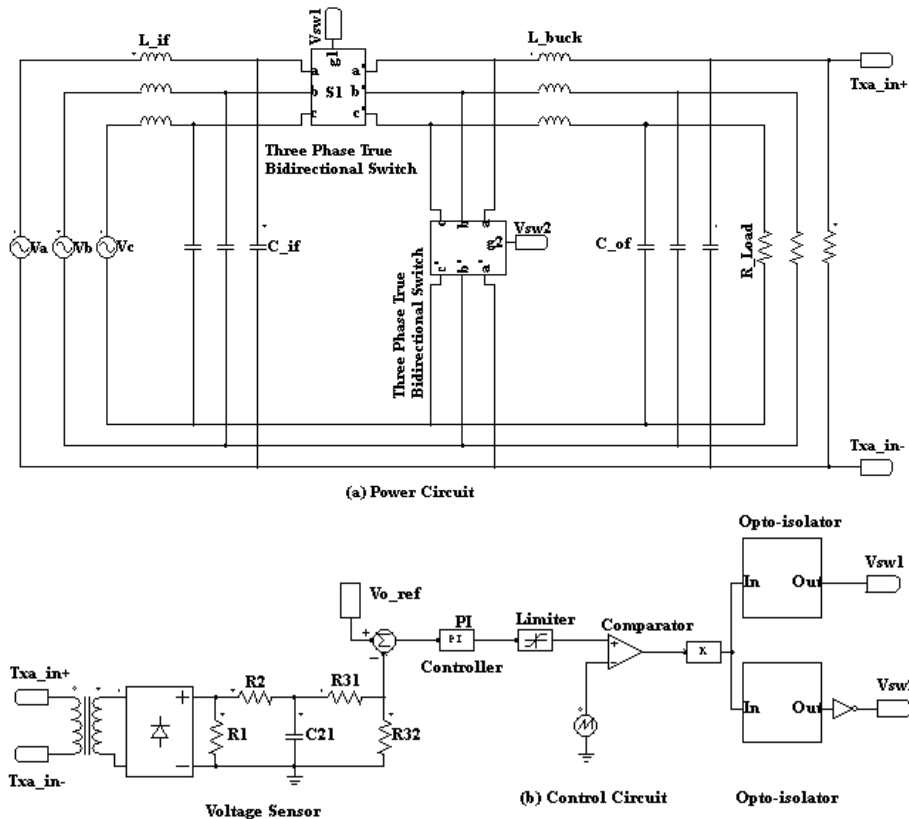

Fig. 6. Voltage mode control of the proposed Buck AC voltage controller with feedback signal taken as DC average of the output voltage of a single phase.

then compared with high frequency triangular wave of 8 kHz to create the desired PWM signals to drive the switches. The generated gate pulses are traversed thru the opto-coupler units to the inputs of two bi-directional switches. In order to make the complimentary gate signal for the bidirectional freewheeling switch one of the gate signals is inverted. In reality commercially existing controller ICs can be employed in this regard with necessary adjustment to acquire the desired inverted gate signal for the freewheeling switch of the three-phase AC voltage controller.

V. SIMULATION RESULTS

The proposed three-phase Buck AC voltage controller has been simulated using PSIM version 9.0 simulation software. In open loop condition the width of the gate pulses is varied and the circuit parameter values are adjusted to get high operating performance from the proposed Buck converter. The circuit parameters and the operating conditions are given in table I below.

TABLE I. CIRCUIT PARAMETERS AND OPERATING CONDITIONS

Source	3-phase balanced ac source Line Frequency: 50 Hz Amplitude: 300V
Switching Frequency	8 kHz
Buck Inductances	4 mH (each)
Input LC Filter	Inductance: 7 mH (each) Capacitance: 1 μ F (each)
Output Filter	Capacitance: 1 μ F (each)

A. Performance Observation by Varying Duty Ratio

In open loop condition by changing the width of the gate drive signals the performance of the proposed Buck converter has been measured in terms of power quality indices such as efficiency, input power factor, percent Total Harmonic Distortion of input current, and voltage gain. The outcomes of the comparisons are illustrated in Figs. 7 - 10.

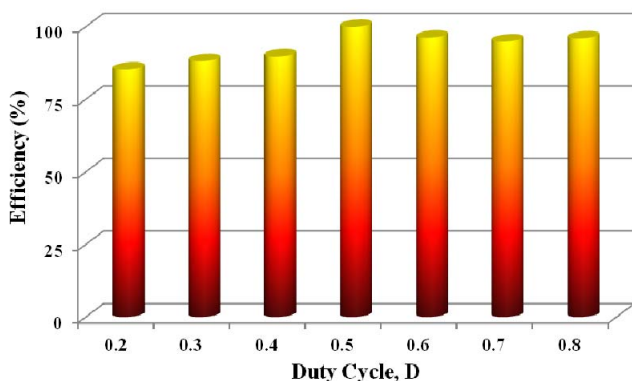

Fig. 7. Performance in terms of efficiency (%) of three-phase Buck AC voltage controller under duty cycle variation.

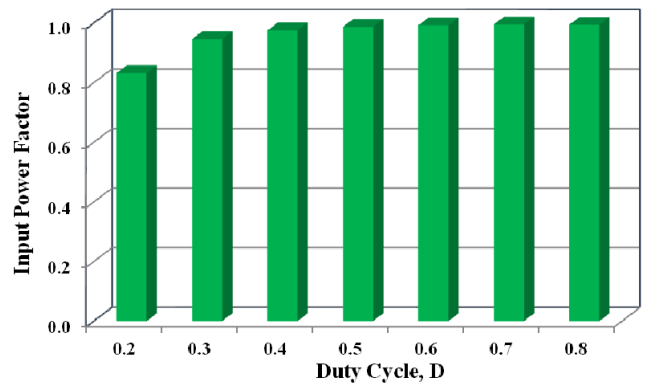

Fig. 8. Performance in terms of input power factor of three-phase Buck AC voltage controller under duty cycle variation.

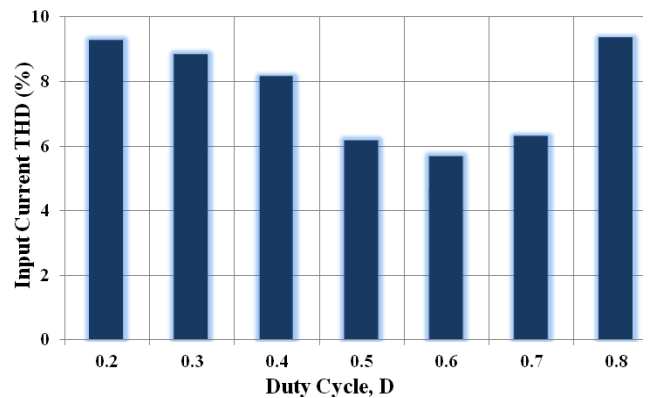

Fig.9. Performance in terms of input current THD (%) of three-phase Buck AC voltage controller under duty cycle variation.

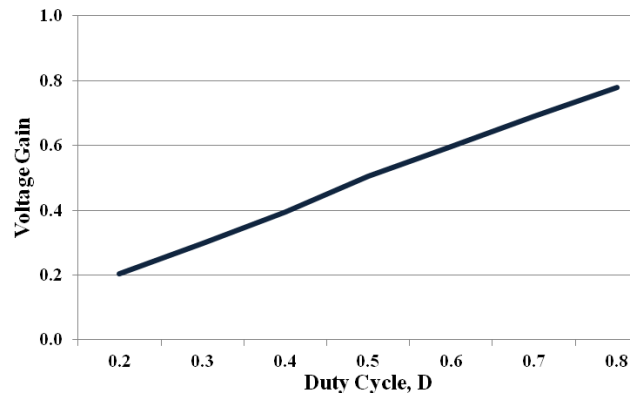

Fig. 10. Performance in terms of voltage gain of three-phase Buck AC voltage controller under duty cycle variation.

In open loop condition with duty cycle variation the proposed three-phase Buck AC-AC converter shows high efficiency operation ranges from 84% to 99%. The power factor is almost unity throughout the range of duty cycle. The input current THDs are found less than 10% all over the duty cycles. The voltage gain with duty cycle variation is linear, follows the theoretical relation of Buck converter.

B. Performance under Closed Loop Control

Fig. 11 shows the typical output voltage and input current wave shapes of the three-phase Buck AC-AC converter, where the output voltage has been controlled at targeted peak value of 150V with voltage mode feedback control using proportional integral (PI) controller. The input current is sinusoidal with percent total harmonic distortion (THD) of 5.4%. The input side power factor has been obtained 0.92 and the efficiency of the converter is 97.05%.

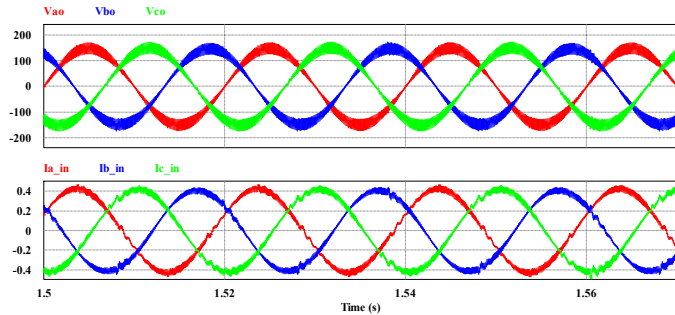

Fig. 11. Controlled output voltage and input current waveforms of the proposed three phase Buck AC-AC converter.

C. Controller Response at Step Load Change

The Proposed Buck converter had experienced sudden load disturbances from the rated load value and the converter performance has been measured under closed loop control. Fig. 12 illustrates the response of output voltage and input current for step changes of load from 100% to 120%. The change of load was occurred at 1.5s, where the converter was in steady state. It has been found that the converter shows good response to sudden disturbances in load. This shows the capability of the proposed controller system to accommodate step load change.

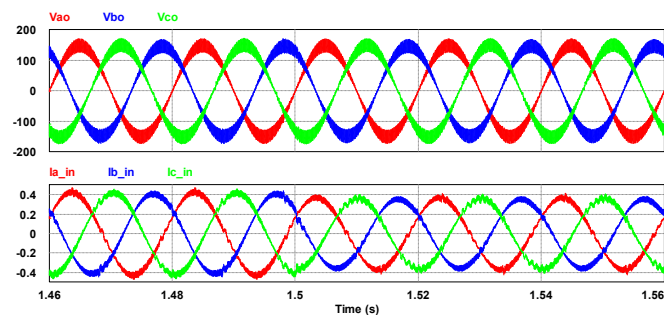

Fig. 12. Response of output voltage and input current wave shapes of Buck converter for sudden load variation at 1.5s.

D. Controller Response at Step Change of Input Voltage

Performance of the converter has also been measured in closed loop condition for sudden change of input voltage from the rated maximum value of 300V. Fig. 13 illustrates the response of the output voltage and input current wave shapes for sudden input voltage change from rated 300V to 330V at 1.5s. It was seen that the output voltage changed momentarily during the input voltage fluctuations. Due to the controller action on the switches, voltage recovered quickly.

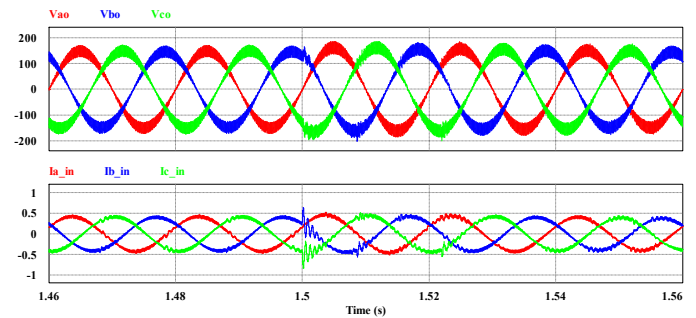

Fig.13. Response of output voltage and input current wave shapes of Buck converter for step input voltage variation at 1.5s.

VI. CONCLUSION

In this paper a new topology of three-phase PWM switch mode Buck AC voltage controller using two three-phase AC bi-directional switches has been presented. The topology can be well thought-out as direct extension of using two bi-directional AC switches in Buck converter topology. Steady state analysis demonstrates the capability of the proposed converter to reach step-down of the instantaneous output voltages with duty ratio control. Closed loop feedback control of the proposed Buck converter shows that simple PI-controller on one phase can regulate the output voltage of the converter with good accuracy. Performance of the converter in terms of efficiency, input power factor, percent total harmonic distortion of input current, etc. has been found satisfactory both in open and closed loop control. For sudden changes in supply voltage or load the controller adjusts the width of the high frequency gate pulses to obtain the desired output voltage quickly. Since the proposed topology uses only two switches, it has the benefits of having reliable operation, simple control, less conduction and switching losses, and cost and complexity reduction of the overall system. Experimental verification will be done in future to justify the validation of the proposed converter.

REFERENCES

- [1] F.L. Luo, Y. Hong, Renewable Energy Systems: Advanced Conversion Technologies and Applications, CRC Press, Taylor & Francis Group, Sep. 2012.
- [2] H. Sarnago, A. Mediano, and O. Lucia, "High efficiency ac-ac power electronic converter applied to domestic induction heating," *IEEE Transactions on Power Electronics*, vol. 27, no. 8, pp. 3676-3684, Aug. 2012.
- [3] J. C. R. Caro, F. M. David, J. M. R. Arredondo, and A. M. Bakir, "Two-switch three-phase ac-link dynamic voltage restorer," *Power Electronics, IET*, vol. 5, no. 9, pp. 1754 - 1763, Nov. 2012.
- [4] M. R. Hajmoradi, E. Karimi, H. Mokhtari, and A. Yazdian, "Performance improvement of a double stage switch mode ac voltage regulator," in *Proc. Power Electronics and Drive Systems Technology (PEDSTC)*, 2012, pp. 181 – 186.
- [5] T. Soeiro, C. A. Petry, C. S. Fagundes, and I. Barbi, "Direct ac-ac converters using commercial power modules applied to voltage restorers," *IEEE Transactions on Industrial Electronics*, vol. 58, no. 1, pp. 278-288, Jan. 2011.
- [6] L. Lei, Y. Jundong, and Z. Qinglong, "Novel family of single-stage three-level ac choppers," *IEEE Transactions on Power Electronics*, vol. 26, no. 2, pp. 504-511, 2011.

- [7] S. Subramanian, and M. K. Mishra, "Interphase ac-ac topology for voltage sag supporter," *IEEE Transactions on Power Electronics*, vol. 25, no. 2, pp. 514-518, Feb. 2010.
- [8] K. Basu, and N. Mohan, "A power electronic transformer for three phase pwm ac/ac drive with loss less commutation and common-mode voltage suppression," in *Proc. 36th Annual Conference on IEEE Industrial Electronics Society, IECON 2010*, pp. 315-320.
- [9] J. C. R. Caro; J. M. Ramirez; and F. Z. Peng, "Simple topologies for AC-link flexible AC transmission systems," in *Proc. 2009 IEEE Bucharest Power Tech Conference*, 28 Jun.-2 Jul. 2009, pp. 1-8.
- [10] F. M. David, S. Bhattacharya, and S. Venkataramanan; "A comparative evaluation of series power-flow controllers using dc- and ac-link converters"; *IEEE Transactions on Power Delivery*, vol. 23, no. 2, pp. 985 - 996, Apr. 2008.
- [11] A. Prasai, J. Sastry, and D. Divan, "Dynamic Var/Harmonic Compensation with Inverter-Less Active Filters," in *Proc. IEEE Industry Applications Society Annual Meeting, 2008. IAS '08*, pp. 1 - 6.
- [12] P. C. Sen, *Modern Power Electronics*, S. Chand & Company Ltd., New Delhi, 2004.
- [13] A. Eberhard, *Power Quality*, ISBN 978-953-307-180-0, In Tech, Rijeka, Croatia, Mar. 2011.
- [14] A. Mozdzer and B.K. Bose, "Three-phase ac power control using power transistors," *IEEE Transactions on Industry Applications*, vol. IA-12, no. 5, pp. 499-505, Sept. 1976.
- [15] P.D. Ziogas, D. Vincenti, and G. Joos, "A practical pwm ac controller topology," in *IEEE Industry Applications Society Annual Meeting*, Oct. 1992, vol. 1, pp. 880-887.
- [16] D. Vincenti, H. Jin, and P.D. Ziogas, "Design and implementation of a 25-kva three-phase pwm ac line conditioner," *IEEE Transactions on Power Electronics*, vol. 9, no. 4, pp. 384-389, July 1994.
- [17] S. Srinivasan, and G. Venkataramanan, "Comparative evaluation of pwm ac-ac converters," in *Proc of the 26th Annual IEEE Power Electronics Specialists Conference*, 18-22 Jun. 1995, vol. 1, pp. 18 - 22.
- [18] F. Z. Peng, L. Chen, and F. Zhang, "Simple topologies of pwm ac-ac converters," *IEEE Power Electronics Letters*, vol. 1, no. 1, pp. 10 - 13, Mar. 2003.
- [19] X. P. Fang, "Three-phase z-source ac-ac converter" in *Proc. of the Power Electronics and Motion Control Conference, EPE-PEMC, 2006*, pp. 621-624.
- [20] M. M. S. Khan, M. S. Arifin, M. H. Rahaman, I. Amin, M.R.T. Hossain, A.H. Abedin, M.A. Choudhury, and M.N. Uddin, "Input switched high performance three phase buck-boost controlled rectifier," in *Proc. 2013 IEEE International Conference on Industrial Technology (ICIT)*, 25-28 Feb. 2013, Cape Town, Western Cape, South Africa, pp. 557 - 562.
- [21] M. R. T. Hossain, A. H. Abedin, M. A. Choudhury, and M. N. Uddin, "True three-phase bidirectional switch based ac-ac buck-boost converter topology," in *Proc. 2013 IEEE Jordan Conference on Applied Electrical Engineering and Computing Technologies (AEECT 2013)*, 3-5 Dec. 2013, Amman, Jordan, pp. 1-6.
- [22] M.R.T. Hossain, M.A. Choudhury, and M.N. Uddin, "A three-phase boost ac-ac voltage converter," in *Proc. 2014 IEEE Industry Applications Society Annual Meeting*, 5-9 Oct. 2014, Vancouver, BC, Canada, pp. 1 - 8.